

Tooling Guide

for High Reliability Electrical Systems



DMC DANIELS
MANUFACTURING
CORPORATION

An ISO9001:2015 and AS9100D Registered Company

Table of Contents

DANIELS MANUFACTURING CORPORATION

526 THORPE ROAD • ORLANDO, FL 32824 U.S.A.
PHONE: (407) 855-6161 • FAX: (407) 855-6884
EMAIL: DMC@DMCTOOLS.COM • WWW.DMCTOOLS.COM
CAGE CODE: 11851

INTRODUCTION

Important Facts About Crimping..... 1

WIRE PREP

Manual and Pneumatic Wire Strippers 2

AS5768 Wire Stripper Info 4-5

M32610 Twist-Strip™ Outer Jacket Stripper..... 6-9

MIL-SPEC INDENT CRIMP TOOLS

M22520/1-01 Standard Adjustable Indent Crimp Tool..... 10

M22520/2-01 Miniature Adjustable Indent Crimp Tool..... 12

M22520/7-01 Middle Range Adjustable Indent Crimp Tool..... 13

M22520/34-01 MIL-DTL-28840 Connector Tooling 13

Pneumatic (Air Powered) Indent Crimp Tools..... 14

Hand-Held Pneumatic Indent Crimp Tools 15

SPECIAL CRIMP TOOLS

M22520/4-01 (GS100-1) & M22520/31-01 (GS200-1)

Circular Indent Crimp Tools 16

SC8 & MH993 (Biased Crimp Tools)..... 19

Mid-Current Range Indent Crimp Tools 20-23

Dedicated Application Indent Crimp Tools 24

LH8 (for Burndy YHMM Series Contacts) 24

GS217 (MIL-C-22442/32-1 Clamping Ring Crimp Tool)..... 24

MH800 (Ultra Precision Crimp Tool) 25

MH820 (Stainless Steel Indenter) 25

MH835 & MH992 Fine Tipped Indent Tools 26

CONTACT INFORMATION

Technical Application Guide for Contacts and Connectors.... 27

Contact Color Code (BIN)..... 27

LIMITED DISCLAIMER (Technical Information) 27

M39029 CONNECTORS APPLICATION GUIDE

M39029 Contact Quick Location Chart..... 28

Connector, Contacts, and Tools Cross Reference 29-73

M39012 COAXIAL CONNECTORS TOOL GUIDE

M39012 Coaxial R.F. Connector Tool Selection Guide..... 74-88

OPEN FRAME CRIMP TOOLS

DMC Y-Dies For a Full Range of Capabilities..... 89

M22520/5-01 Open Frame Crimp Tool..... 90

M22520/10-01 Open Frame Crimp Tool..... 90

HXE4B Battery Powered Hydraulic Tool..... 92

UDT5 & UDT3 Bench Press Style Open Frame Crimp Tool... 93

HX33 Pneumatic Open Frame Crimp Tool..... 93

HX23 Pneumatic Open Frame Crimp Tool..... 94

EMC3300 CRIMP TOOL

EMC3300 Electro Mechanical Crimp Tool and Dies..... 95

DCT SERIES CRIMP TOOLS

DCT Series Crimp Tools & Dies..... 96-97

GMT SERIES CRIMP TOOLS

Hand-Held GMT Series Crimp Tools..... 98

GMT Series Crimp Tools and Gages..... 99

Battery Powered Hydraulic GMT Crimp Tools 100

M81824 Splice (PMT232) Pneumatic Crimp Tool..... 101

LARGE GAGE CRIMP TOOLS

HD36 Die 3.5 Ton Hydraulic Crimp Tool..... 102

HD36 Die 4 Ton Battery Powered Hydraulic Crimp Tool..... 103

M22520/23-01 WA23 Pneumatic Indent Crimp Tool..... 104

Large Gage Contact Application Information..... 105

Pico to DMC Part Number Guide..... 106-108

Dieless 4 Indent Crimpers/Pumps..... 109

HD51 Hydraulic 5.5 Ton Crimp Tool..... 110-111

HD120 12 Ton Hydraulic Crimp Tool 112

TBHD1M (MS25441-1) 12 Ton Hydraulic Crimp Head 112

MS23002, MS25442, & MS90485 (AS2529) Crimp Tools & Dies.. 113

TERMINAL AND SPLICE TOOLING OPTIONS

Terminal and Splice Tooling Options..... 114-162

I/R TOOLS

AS81969 (M81969) Installing and Removal Tools..... 163-169

AS81969 (M81969) I/R Tools Part Number Guide..... 165-167

Unwired Contact Removal Tools (M81969/30)..... 169

Wire Harness Tools..... 170

Contact Retention Test Tools..... 171

Contact Retention Test Tools 171

Contact Retention Test Tool Calibration Equipment..... 172

Contact Gages..... 172

BETA BACKSHELL TOOLS

BETA Backshell Tools 173

BETA Backshell Torque Tools Quick Reference 174

EMI/RFI Band Application System (M85049/128 Bands)..... 175

M81306/1 One-Step Banding Tool System 177

M81306/2 Two-Step Banding Tool System 178

M85049/128 Band Application System Mil Part Number Guide..... 179

M85049/128 Band Application System DMC Part Number Guide. 180-181

TENSILE TESTING

Tensile Test Systems (Wire Crimp Pull Testers)..... 182-188

Wire Standards Pull Test Value Guide 189

SWAGING TOOL & DIES

Wire Rope Swaging Tool & Dies (Tool Kit) 190-191

WIRING SYSTEMS MAINTENANCE KITS

Wiring System Maintenance Kits 192-195

REPAIR AND CALIBRATION

Repair and Calibration 196-197

LIMITED WARRANTY 198

Ergonomics Challenge 199

NOTICE: ANY PRICES WE QUOTE VERBALLY OR ANY PRICES APPEARING IN OUR PRINTED PRICE LISTS ARE SUBJECT TO CHANGE WITHOUT PRIOR NOTICE. IF YOU NEED FIRM PRICES FOR FUTURE DELIVERIES YOU SHOULD REQUEST A WRITTEN QUOTATION FROM OUR SALES OFFICE. WE ARE NOT LIABLE FOR CONSEQUENTIAL OR SPECIAL DAMAGES OF ANY NATURE OR KIND, RESULTING FROM THE USE OF ANY OF OUR PRODUCTS.

Important Facts About Crimping

TIME LINE FOR CRIMP TECHNOLOGY

1940s	All terminations were soldered (Hard-wired)
1953	AMP introduced Crimp Barrel Terminals
1957	Cannon Brothers experimented with Machined Contacts with Crimp Barrels for Crimping
1960	Buchanan introduced the 4 Indent Crimp Tool with a Ratchet (Ref: MS3191)
1963	MS3191-1 was published as the first Crimp Tool Standard
1965	MS3191-4 introduced by Daniels Manufacturing Corporation
1969	MIL-T-22520 published and dated to replace all previous specifications
1974	Changed to MIL-C-22520, and many Slash Sheets added
1996	Changed to MIL-DTL-22520
Present	SAE AS22520

CRIMPING: THEN AND NOW

The first multi-pin connectors were terminated by soldering the conductor to non-removable contacts. However, high temperature applications and the need for simple and reliable field service led to the introduction of connectors with removable contacts. These were crimped onto the conductor rather than being soldered.

The first standard crimp tool developed to crimp these new contacts was introduced in the early sixties. MS3191-1, a military drawing, defined this tool and its accessories. The MS3191-1 utilized a 4 indent crimp pattern together with a positive stop locator which controlled the travel of the indenters (crimp depth).

The MS3191-1 design was a compromise between simplicity of operation and crimp performance since the crimp depth for any given contact was not adjustable to accommodate the differing diameters of the conductors to which it would be crimped. It was, however, suitable for the crimp connectors of that era.

An improved tool design featuring independently adjustable crimp depths was soon introduced as MS3191-4. The MS3191-4 had an internal adjustment, totally independent of the locator, which permitted the selection of seven separate crimp depths, allowing optimal crimping of conductors ranging from AWG 12 to 26 regardless of the wire barrel size of

the contact.

MS3191-4 also introduced the use of the double tipped indenter to produce an 8 indent crimp pattern which has consistently achieved superior tensile pull off values and mechanical properties.

MS3191-4 introduced the concept of a turret head containing three locators which could be used without separating any of them from the basic crimp tool.

In 1969, two military specifications for crimp tools were developed to replace the existing military drawings. They were MIL-T-22520C (Navy) and MIL-T-83724 (USAF) which defined a standard size crimp tool similar to the MS3191-4, but with an expanded 8 step crimp depth range. These specifications also defined a miniature crimp tool to crimp conductors as small as AWG 32.

Both documents were combined in 1971 into MIL-C-22520D. All previous military standards for crimp tools were then cancelled including the MS3191. This list includes specifications for indent crimp tools, terminal lug crimp tools, pneumatic tools, coaxial cable crimp tools and other specialized crimp tools.

MIL-DTL-22520 established a single specification which set forth performance requirements for all crimp tools to be used on military standard electrical connectors. This eliminated the waste and confusion which accompanied the overlapping applications of many different "standard" crimp tools called out by a deluge of unrelated military drawings.

THE CRIMPING CONCEPT

Crimping is a method of firmly attaching a terminal or contact end to an electrical conductor by pressure forming or reshaping a metal barrel together with the conductor. The forming of a satisfactory crimp depends on the correct combination of conductor, crimp barrel and tool.

When applied with a properly matched tool, a union is established which has both good electrical and mechanical characteristics. The tool will provide these requirements consistently and reliably with repeatability assured by quality cycle controlled tooling. There are several common configurations of crimped joint; several examples are shown below.

The electrical resistance of a properly designed and controlled crimped joint should be equal to, or less than, the

resistance of an equal section of wire. Specifications state the requirements in terms of millivolt drop at a designated current.

The mechanical strength of a crimped joint and hence, its pull-out force (tensile strength), varies with the deformation applied (i.e. the crimp die of the tool determines the crimp configuration and deformation). Therefore, by properly shaping the deformation, a high pull-out force can be achieved, .

The dies in the tool determine the completed crimp configuration which is generally an element of contact and/or connector design. Some of the design considerations are: a) The type of contact, its size, shape, material and function, b) The type and size of wires to be accommodated, c) The type of tooling into which the configuration must be built.

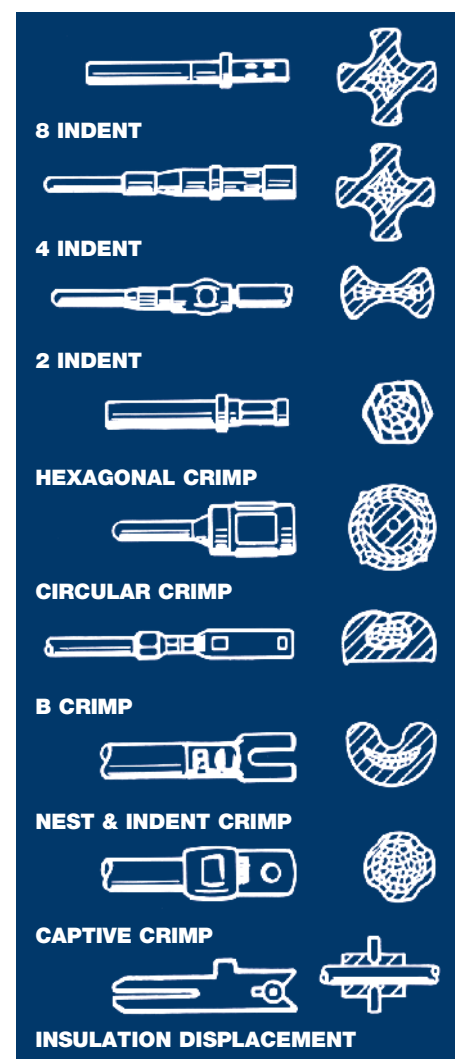

Wire Preparation

PNEUMATIC WIRE STRIPPERS

The **WSP-1630**, **WSP-1014**, and **WSP-1626E** series Pneumatic Wire Strippers are the ultimate combination of performance, reliability, and portability. They were developed in cooperation with major aerospace contractors addressing their needs for a reliable, simple to operate, pneumatic wire stripper utilizing the blades and accessories that are approved for AS5768.

The **WSP-1630** Pneumatic Wire Stripper's Compact Design allows the hand-held tool to be used in confined areas (7" x 2.5"). The 1.5 lb weight and pneumatic actuation system minimize operator fatigue and carpal tunnel injuries.

Fast, smooth stripping operation results in maximum quality wire preparation at a production rate unattainable with hand operated

mechanical strippers.

Compatibility with common, commercially available stripper blades, grippers, and other components makes the unit economical, and it assures a wide range of applications with all types of wire. A Rotatable Head permits left or right hand operation and a Wire Stop may be used for precise, repeatable operations.

Adjustable Speed Control allows the operator to regulate the speed of the stripping operation by simply rotating the adjustment collar which is a part of the air hose. This enables greater accuracy and control of the wire stripper.

The **WSP-1626E** Pneumatic Wire Stripper is for hand held stripping of most insulated wire from 16-26 AWG. The tool accommodates Ergo Elite Stripmaster® Laminated blades and pads made by Ideal Industries, Inc. The wire stripper features a 360° rotatable head section.

The **WSP-1014** Pneumatic Wire Stripper is for hand held stripping of most insulated wire from 10-14 AWG. The tool accommodates Custom Stripmaster® and Custom Steel Stripmaster® industry standard blades and pads made by Ideal Industries, Inc. The wire stripper features a 360° rotatable head section that enables positioning of the head to most comfortable position for left or right-handed operators.

The **WSP-FPSA** is a bench mount and foot pedal that is compatible with all DMC Pneumatic Wire Strippers.

MANUAL WIRE STRIPPERS

The Custom Stripmaster® and the Custom Stripmaster® Lite strip wire from 10-30 AWG. Each tool features cushioned, non-slip comfort-grip handles.

Both tools are available with an optional short stop latch and transparent wire stop. Each tool accommodates Custom Stripmaster® Laminated blades and pads made by Ideal Industries, Inc.

The Custom Stripmaster® Lite is three-quarters the size of Custom Stripmaster® Wire Stripper and requires one-third less hand pressure for each strip than the Custom Stripmaster.

The Ergo-Elite 55-1987 manual wire stripper is ergonomically engineered for superior comfort, balance and control. It is constructed of rigid polyurethane reinforced with carbon fiber providing excellent strength at 40% the weight of metal hand tools. It strips wire from 16-26 AWG. It is available with a transparent wire stop.

The Ergo-Elite 55-1987 features one-step stripping action. The tool grips, penetrates, and removes wire insulation with unmatched precision in one effortless squeeze. The Ergo-Elite 55-1987 accommodates Ergo-Elite Stripmaster® Laminated blades and pads made by Ideal Industries, Inc.

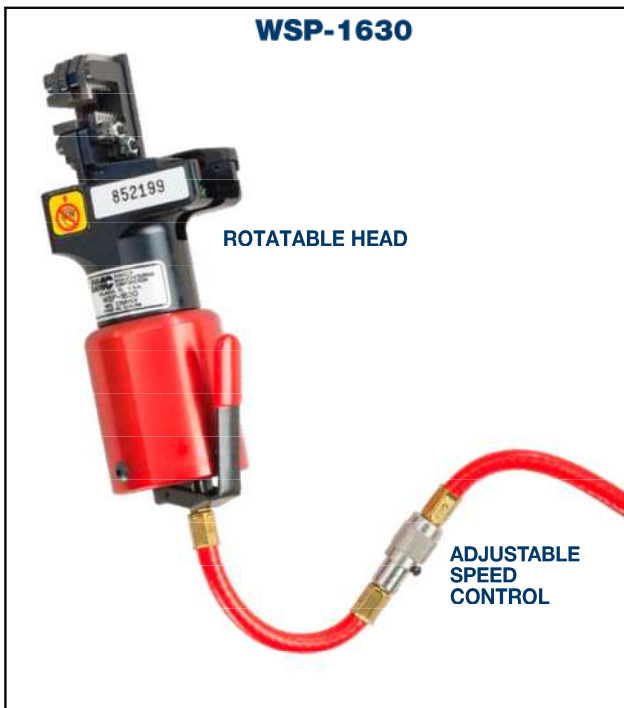

Features Include:

- Compact Design
- Minimize operator fatigue and carpal tunnel injuries
- Fast actuation
- Compatibility with common, commercially available stripper blades, grippers, and other components
- Rotatable Head permits left or right hand operation
- Wire Stop for precise, repeatable operations
- Adjustable Speed Control
- Optional WSP-FSA is a bench mount and foot pedal that is compatible with all DMC Pneumatic Wire Strippers

Wire Preparation

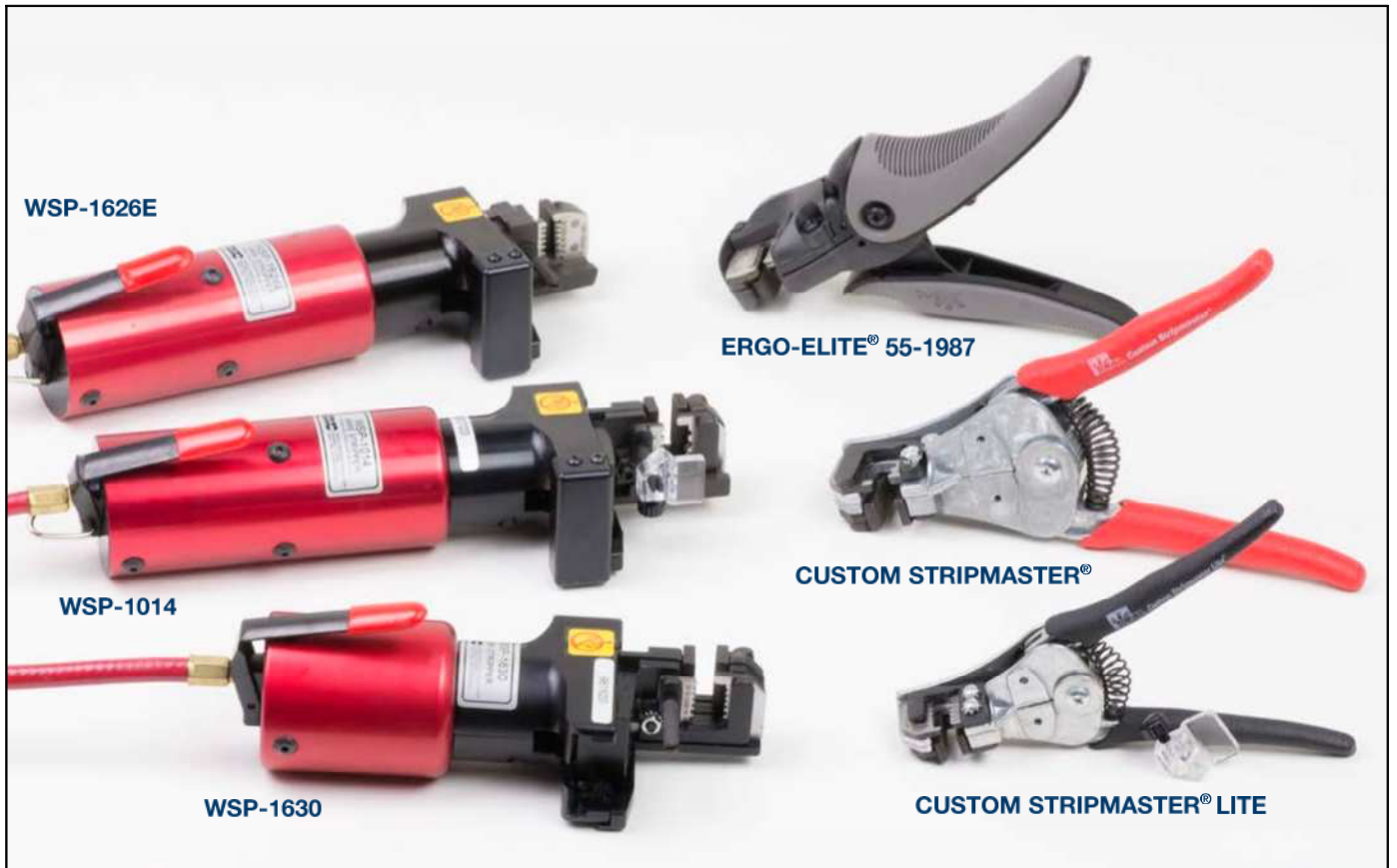

Wire Preparation

WIRE STRIPPING TECHNIQUE



1. Determine the proper length of insulation to be removed. Wire must be visible in inspection hole. Less than 50% of overall wire diameter clearance between insulation and contact barrel.
2. Insert wire into exact center of correct slot for wire size to be stripped. Each slot is marked with wire size.
3. Close handles together as close as possible.
4. To prevent birdcaging, partially open handles allowing grips to open, then remove wire before allowing handles to fully open.
5. Release handles, allowing wire holder to return to open position.
6. Remove stripped wire.
7. After stripping, strands of wire should be twisted firmly together in the same direction as the normal lay of the wire.
8. Stripped wire with nicked or cut strands is not acceptable.

AS5768 Wire Stripper Info

Wire Preparation

WIRE STRIPPER BLADES AND ACCESSORIES

WIRE SPECIFICATION TOOL & BLADE	MANUAL WIRE STRIPPER TOOL & BLADE (SAE P/N)	MANUAL WIRE STRIPPER TOOL ONLY P/N	PNEUMATIC WIRE STRIPPER TOOL ONLY P/N	WIRE STRIPPER BLADE ONLY (SAE P/N)	WIRE STRIPPER BLADE ONLY P/N	WIRE SIZE	NSN
AS50861/1, /2, /4-7, AS22759/2	AS5768/1-T1	45-1147	WSP-1014	AS5768/1-B1	45-1147-1	10-14	N/A
AS50861/1, /2, /4-7	AS5768/1-T2	45-1302	WSP-1630	AS5768/1-B2	45-1302-1	16-22	N/A
AS22759/5, /6	AS5768/1-T3	45-500	WSP-1630	AS5768/1-B3	45-500-1	16-22	5110-01-377-2272
AS22759/7, /8	AS5768/1-T4	45-1500	WSP-1630	AS5768/1-B4	45-1500-1	16-22	5110-01-377-2237
AS22759/9-12, /16, /17, /20-23, /28-35, /41-46, AS81044/11-13, AS85485/9-12, MIL-DTL-81381/3, /4	AS5768/1-T5	45-1611	WSP-1014	AS5768/1-B5	45-1611-1	10-14	5110-01-373-2486
AS22759/9-12, /20-23, /28-31	AS5768/1-T6	45-177	WSP-1630	AS5768/1-B6	L-5560	16-26	5110-00-177-7286 5110-01-3772-181
AS22759/9-12, /20-23, /28-31, /34, /35, /41-43, AS81044/7-14, /21, /22, MIL-DTL-81381/3, /4, /7-14, /21, /22	AS5768/1-T7	45-178	WSP-1630	AS5768/1-B7	L-5561	26-30	5110-00-145-8171
AS22759/11, /12, /16, /17, MIL-DTL-81381/11-14, /22	AS5768/1-T8	45-1654	WSP-1630	AS5768/1-B8	45-1654-1	16-26	5110-01-377-2245
AS22759/16, /17, /32-35, /41-46	AS5768/1-T9	45-1987	WSP-1630	AS5768/1-B9	45-1987-1	16-26	5110-01-373-2487
AS22759/16, /17, /32-35, /41-46	AS5768/1-T10	45-1551	WSP-1630	AS5768/1-B10	45-1551-1	16-26	5110-01-377-2271
AS22759/18, /19, MIL-DTL-81381/11-14, /22	AS5768/1-T11	45-1608	WSP-1014	AS5768/1-B11	45-1608-1	10-14	5110-01-377-2313
AS22759/80-82, /91, /92, /180-182, /191, /192	AS5768/1-T12	45-2542	WSP-1014	AS5768/1-B12	45-2542-1	10-14	5110-01-520-8380
AS22759/80-82, /91, /92, /180-182, /191, /192	AS5768/1-T13	45-2544	WSP-1630	AS5768/1-B13	45-2544-1	16-26	N/A
AS22759/86-90, /186-190	AS5768/1-T14	45-2541	WSP-1014	AS5768/1-B14	45-2541-1	10-14	N/A
AS22759/86-90, /186-190	AS5768/1-T15	45-2618	WSP-1630	AS5768/1-B15	45-2618-1	16-26	5110-01-520-8379 5110-01-530-2382
AS81044/5-7	AS5768/1-T16	45-170	WSP-1014	AS5768/1-B16	L-5210	10-14	5110-01-380-9356
AS81044/5-7	AS5768/1-T17	45-171	WSP-1014 WSP-1630	AS5768/1-B17	L-5211	10-14	5110-01-373-2484
AS81044/8-10	AS5768/1-T18	45-173	WSP-1014	AS5768/1-B18	L-5562	10-14	5110-01-377-2167
AS81044/8-10	AS5768/1-T19	45-174	WSP-1630	AS5768/1-B19	L-5563	16-26	5110-01-377-2180

AS5768 Wire Stripper Info

WIRE STRIPPER BLADES AND ACCESSORIES

WIRE SPECIFICATION TOOL & BLADE	MANUAL WIRE STRIPPER TOOL & BLADE (SAE P/N)	MANUAL WIRE STRIPPER TOOL ONLY P/N	PNEUMATIC WIRE STRIPPER TOOL ONLY P/N	WIRE STRIPPER BLADE ONLY (SAE P/N)	WIRE STRIPPER BLADE ONLY P/N	WIRE SIZE	NSN
AS81044/11-/13, AS85485/9-/12 MIL-DTL-81381/3, /4	AS5768/1-T20	45-1610	WSP-1630	AS5768/1-20	45-1610-1	16-26	5110-00-088-1598 5110-01-373-2485
MIL-DTL-81381/1, /2, /5-/10, /17-/21	AS5768/1-T21	45-1609	WSP-1014	AS5768/1-B21	45-1609-1	10-14	5110-01-380-9344
MIL-DTL-81381/17-/20	AS5768/1-T22	45-1672	WSP-1630	AS5768/1-B22	45-1672-1	16-26	N/A
AS85485/5-/8	AS5768/1-T23	45-1925	WSP-1014	AS5768/1-B23	45-1925-1	10-14	5110-01-380-9387
AS85485/5-/8	AS5768/1-T24	45-1924	WSP-1630	AS5768/1-B24	45-1924-1	16-26	5110-01-377-2247
AS22759/9, /10, /13-/15 MIL-DTL-81381/3, /4	AS5768/2-T1	45-638	N/A	AS5768/2-B1	LB-918	16-22	N/A
AS22759/9, /10, /13-/15 MIL-DTL-81381/3, /4	AS5768/2-T2	45-640	N/A	AS5768/2-B2	LB-920	24-30	N/A
AS22759/32, /34, /35, /41-/43 MIL-DTL-81381/1, /2, /6-/14, /17-/22	AS5768/2-T3	45-2203	N/A	AS5768/2-B3	45-2203-1	24-30	N/A
AS22759/32, /34, /35, /41-/43	AS5768/2-T4	45-2133	N/A	AS5768/2-B4	45-2133-1	16-24	N/A
AS22759/80, /81, /91, /92, /180-/182, /191, /192	AS5768/2-T5	45-2698	N/A	AS5768/2-B5	45-2698-1	16-24	N/A
AS22759/80, /81, /91, /92, /180-/182, /191, /192	AS5768/2-T6	45-2692	N/A	AS5768/2-B6	45-2692-1	20-26	N/A
AS22759/86-/90, /186-/190	AS5768/2-T7	45-2243	N/A	AS5768/2-B7	45-2243-1	16-24	N/A
AS22759/86-/90, /186-/190	AS5768/2-T8	45-2297	N/A	AS5768/2-B8	45-2297-1	20-26	N/A
AS81044/6, /7	AS5768/2-T9	45-2204	N/A	AS5768/2-B9	LB-2204-1	16-24	N/A
AS81044/6, /7	AS5768/2-T10	45-2205	N/A	AS5768/2-B10	LB-2205-1	20-26	N/A
AS81044/12, /13, AS22759/40-/54	AS5768/2-T11	45-2133	N/A	AS5768/2-B11	45-2133-1	16-24	N/A
AS81044/12, /13	AS5768/2-T12	45-2224	N/A	AS5768/2-B12	45-224-1	24-30	N/A
MIL-DTL-81381/1, /2, /6-/14, /17-/22	AS5768/2-T13	45-2124	N/A	AS5768/2-B13	45-2124-1	16-24	N/A
AS22759/32-46/16/17 MIL-DTL-81044/11/12/13 BMS 13-48 (10, 8, 6 MIL)	N/A	55-1987 (ERGO ELITE)	WSP-1626E	N/A	55-1987-1	16-26	N/A

The Industry Standard for Wire Strippers (AS5768, Tool, Stripper, Electrical Insulation, General Specification For) was developed to organize, define, and provide QPL source management for wire strippers and blades used in Aerospace and Commercial applications. The AS5768 Specification is available from www.SAE.org.

Twist-Strip™ Outer Jacket Stripper

TWIST-STRIP™ OUTER JACKET STRIPPER FOR SHIELDED TWISTED CABLE



TSK8000 (M32610/01-01)

Cable Dia. Range .081" - .180"

TSK8500

Cable Dia. Range .181" - .310"

SAFER, FASTER, AND MORE ACCURATE THAN RAZOR BLADES

It is common for high-speed data cable to utilize two or more shielded twisted conductors. This type of cable is common in all digital electronic networks, and it requires new tooling disciplines. The challenge in designing a wire prep system of this type is the non-circular configuration of the cable, and the many types, variations, and stripping nuances of shielded, twisted, multi-wire cable.

ELIMINATES IMPRECISE METHODS

Stripping multi-conductor wire cable is often done by hand with a razor blade. This is a dangerous and difficult way to remove the jacket from any type of electrical cable. A razor blade offers no method of controlling the depth of cut which will result in a poor quality strip, and cuts or scrapes on the shielding which lead to poor electrical bond and a likely place for corrosion.

REDUCES RISK OF INJURY

Using a razor blade increases the probability of injury to the operator and constant tugging to remove the outer jacket which causes operator fatigue. Other methods for removal of the jacket like laser or thermal stripping produce hazardous work environments.

TIME SAVING

The conventional "ring and slit" method for stripping shielded twisted cable is very time consuming and requires a highly skilled operator to successfully perform.

The DMC Twist-Strip™ product line gives the user a system with the maximum capabilities, while keeping the system portable, self-contained, affordable, and ergonomic. The precise blade adjustment, zero friction ball bearing design, articulating/locking arms, and changeable dies make the Twist-Strip™ very user-friendly and efficient when performing the difficult task of cable preparation.

ADJUSTABLE (NEW FEATURE)

The TSK8000 and TSK8500 have adjustable blades that allow the tool to accommodate variances in the cable. Varying jacket thickness and cable diameter are two examples of common differences you may see in different lots of the same cable. Simple adjustments allow the user to set the cutting blades for a deeper or shallower score of the cable jacket.

PRECISE

A cable track, precisely machined into each die set, creates a controlled rotation of the dies/blades as the cable is moved along the cable. A simple 90° bend of the cable results in the jacket halves separating for removal, reducing the amount of force needed to remove the jacket.

CONSISTENT

The repeatable function of the tool reduces operator error and is up to 3 to 5 times faster than conventional methods.



Traditional strip with razor blade



Potential damage with razor blade

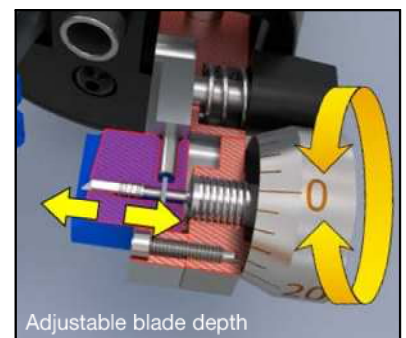

Adjustable blade depth



3x's faster than razor blade

TSK8000 Die Set Selection

TSK8000 Die Set Part Numbering System - 1 Inner Conductor

Tool Frame PN	Die Set PN	MIL Die Set PN	Conductors	Cable OD Range	Cable Lay
TSK8000	TSD1070	N/A	1	.061 to .070"	N/A
TSK8000	TSD1080	N/A	1	.071 to .080"	N/A
TSK8000	TSD1090	N/A	1	.081 to .090"	N/A
TSK8000	TSD1100	N/A	1	.091 to .100"	N/A
TSK8000	TSD1110	N/A	1	.101 to .110"	N/A
TSK8000	TSD1120	N/A	1	.111 to .120"	N/A
TSK8000	TSD1130	N/A	1	.121 to .130"	N/A
TSK8000	TSD1140	N/A	1	.131 to .140"	N/A
TSK8000	TSD1150	N/A	1	.141 to .150"	N/A
TSK8000	TSD1160	N/A	1	.151 to .160"	N/A
TSK8000	TSD1170	N/A	1	.161 to .170"	N/A
TSK8000	TSD1180	N/A	1	.171 to .180"	N/A

Cable Measurement Method One Conductor

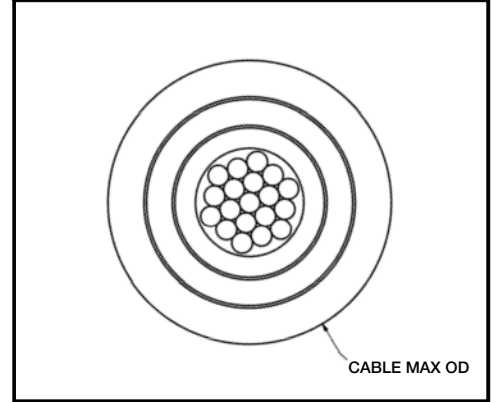

TSK8000 Die Set Part Numbering System - 2 Inner Conductors

Tool Frame PN	Die Set PN	MIL Die Set PN	Conductors	Cable OD Range	Cable Lay
TSK8000	TSD2090	M32610/01-03	2	.081 to .090"	Left Lay
TSK8000	TSD2100	M32610/01-04	2	.091 to .100"	Left Lay
TSK8000	TSD2110	M32610/01-05	2	.101 to .110"	Left Lay
TSK8000	TSD2120	M32610/01-06	2	.111 to .120"	Left Lay
TSK8000	TSD2130	M32610/01-07	2	.121 to .130"	Left Lay
TSK8000	TSD2140	M32610/01-08	2	.131 to .140"	Left Lay
TSK8000	TSD2150	M32610/01-09	2	.141 to .150"	Left Lay
TSK8000	TSD2160	M32610/01-10	2	.151 to .160"	Left Lay
TSK8000	TSD2170	M32610/01-11	2	.161 to .170"	Left Lay
TSK8000	TSD2180	M32610/01-12	2	.171 to .180"	Left Lay

Cable Measurement Method Two Conductor

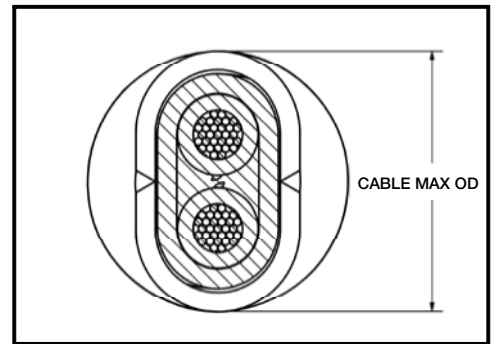

TSK8000 Die Set Part Numbering System - 3 Inner Conductors

Tool Frame PN	Die Set PN	MIL Die Set PN	Conductors	Cable OD Range	Cable Lay
TSK8000	TSD3090	M32610/01-13	3	.081 to .090"	Left Lay
TSK8000	TSD3100	M32610/01-14	3	.091 to .100"	Left Lay
TSK8000	TSD3110	M32610/01-15	3	.101 to .110"	Left Lay
TSK8000	TSD3120	M32610/01-16	3	.111 to .120"	Left Lay
TSK8000	TSD3130	M32610/01-17	3	.121 to .130"	Left Lay
TSK8000	TSD3140	M32610/01-18	3	.131 to .140"	Left Lay
TSK8000	TSD3150	M32610/01-19	3	.141 to .150"	Left Lay
TSK8000	TSD3160	M32610/01-20	3	.151 to .160"	Left Lay
TSK8000	TSD3170	M32610/01-21	3	.161 to .170"	Left Lay
TSK8000	TSD3180	M32610/01-22	3	.171 to .180"	Left Lay

Cable Measurement Method Three Conductor

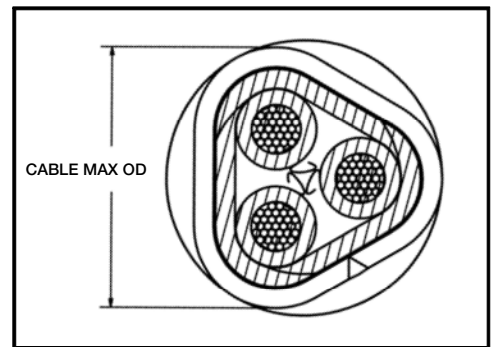

TSK8000 Die Set Part Numbering System - 4 Inner Conductors

Tool Frame PN	Die Set PN	MIL Die Set PN	Conductors	Cable OD Range	Cable Lay
TSK8000	TSD4100	N/A	4	.091 to .100"	Left Lay
TSK8000	TSD4110	N/A	4	.101 to .110"	Left Lay
TSK8000	TSD4120	N/A	4	.111 to .120"	Left Lay
TSK8000	TSD4130	N/A	4	.121 to .130"	Left Lay
TSK8000	TSD4140	N/A	4	.131 to .140"	Left Lay
TSK8000	TSD4150	N/A	4	.141 to .150"	Left Lay
TSK8000	TSD4160	N/A	4	.151 to .160"	Left Lay
TSK8000	TSD4170	N/A	4	.161 to .170"	Left Lay
TSK8000	TSD4180	N/A	4	.171 to .180"	Left Lay

Cable Measurement Method Four Conductor

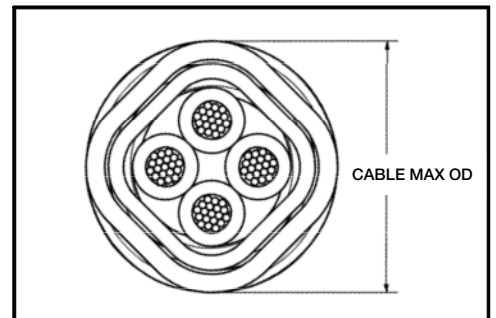

TSK8500 Die Set Selection

Wire Preparation

TSK8500 Die Set Part Numbering System - 1 Inner Conductor

Tool Frame PN	Die Set PN	# of Conductors	Cable OD Range	Cable Lay
TSK8500	TSDL1190	1	.181 to .190	N/A
TSK8500	TSDL1200	1	.191 to .200	N/A
TSK8500	TSDL1210	1	.201 to .210	N/A
TSK8500	TSDL1220	1	.211 to .220	N/A
TSK8500	TSDL1230	1	.221 to .230	N/A
TSK8500	TSDL1240	1	.231 to .240	N/A
TSK8500	TSDL1250	1	.241 to .250	N/A
TSK8500	TSDL1260	1	.251 to .260	N/A
TSK8500	TSDL1270	1	.261 to .270	N/A
TSK8500	TSDL1280	1	.271 to .280	N/A
TSK8500	TSDL1290	1	.281 to .290	N/A
TSK8500	TSDL1300	1	.291 to .300	N/A
TSK8500	TSDL1310	1	.301 to .310	N/A

TSK8500 Die Set Part Numbering System - 2 Inner Conductors

Tool Frame PN	Die Set PN	# of Conductors	Cable OD Range	Cable Lay
TSK8500	TSDL2190	2	.181 to .190	Left Lay
TSK8500	TSDL2200	2	.191 to .200	Left Lay
TSK8500	TSDL2210	2	.201 to .210	Left Lay
TSK8500	TSDL2220	2	.211 to .220	Left Lay
TSK8500	TSDL2230	2	.221 to .230	Left Lay
TSK8500	TSDL2240	2	.231 to .240	Left Lay
TSK8500	TSDL2250	2	.241 to .250	Left Lay
TSK8500	TSDL2260	2	.251 to .260	Left Lay
TSK8500	TSDL2270	2	.261 to .270	Left Lay
TSK8500	TSDL2280	2	.271 to .280	Left Lay
TSK8500	TSDL2290	2	.281 to .290	Left Lay
TSK8500	TSDL2300	2	.291 to .300	Left Lay
TSK8500	TSDL2310	2	.301 to .310	Left Lay

TSK8500 Die Set Part Numbering System - 3 Inner Conductors

Tool Frame PN	Die Set PN	# of Conductors	Cable OD Range	Cable Lay
TSK8500	TSDL3190	3	.181 to .190	Left Lay
TSK8500	TSDL3200	3	.191 to .200	Left Lay
TSK8500	TSDL3210	3	.201 to .210	Left Lay
TSK8500	TSDL3220	3	.211 to .220	Left Lay
TSK8500	TSDL3230	3	.221 to .230	Left Lay
TSK8500	TSDL3240	3	.231 to .240	Left Lay
TSK8500	TSDL3250	3	.241 to .250	Left Lay
TSK8500	TSDL3260	3	.251 to .260	Left Lay
TSK8500	TSDL3270	3	.261 to .270	Left Lay
TSK8500	TSDL3280	3	.271 to .280	Left Lay
TSK8500	TSDL3290	3	.281 to .290	Left Lay
TSK8500	TSDL3300	3	.291 to .300	Left Lay
TSK8500	TSDL3310	3	.301 to .310	Left Lay

TSK8500 Die Set Part Numbering System - 4 Inner Conductors

Tool Frame PN	Die Set PN	# of Conductors	Cable OD Range	Cable Lay
TSK8500	TSDL4190	4	.181 to .190	Left Lay
TSK8500	TSDL4200	4	.191 to .200	Left Lay
TSK8500	TSDL4210	4	.201 to .210	Left Lay
TSK8500	TSDL4220	4	.211 to .220	Left Lay
TSK8500	TSDL4230	4	.221 to .230	Left Lay
TSK8500	TSDL4240	4	.231 to .240	Left Lay
TSK8500	TSDL4250	4	.241 to .250	Left Lay
TSK8500	TSDL4260	4	.251 to .260	Left Lay
TSK8500	TSDL4270	4	.261 to .270	Left Lay
TSK8500	TSDL4280	4	.271 to .280	Left Lay
TSK8500	TSDL4290	4	.281 to .290	Left Lay
TSK8500	TSDL4300	4	.291 to .300	Left Lay
TSK8500	TSDL4310	4	.301 to .310	Left Lay

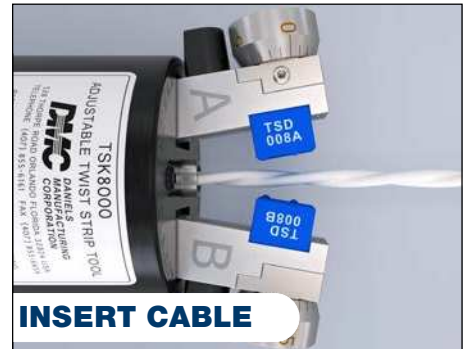

INSERT CABLE

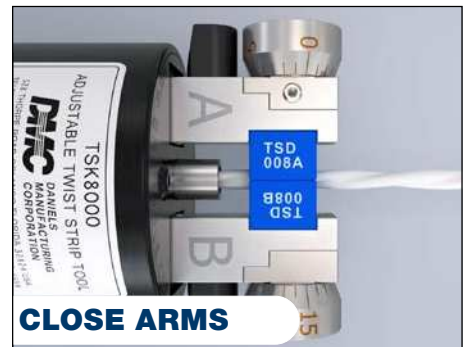

CLOSE ARMS

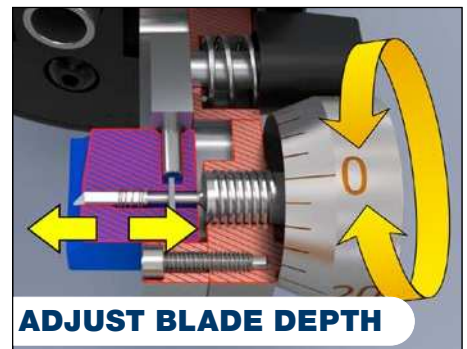

ADJUST BLADE DEPTH



STRIP CABLE JACKET



COMPLETED STRIP

Twist-Strip™ Kits

DMC works to provide the most comprehensive solutions for high speed data and shielded, twisted, multi-conductor cable preparation.

- TSK8000: Twist Strip Kit* with TSK8000 (M32610/01-01) Only
- TSK8001: Twist Strip Kit* with TSK8000 w/All (12) 1 Conductor Die Sets (Cable DIA range 0.061" to 0.180")
- TSK8002: Twist Strip Kit* with TSK8000 (M32610/01-23) w/All (10) 2 Conductor Die Sets (Cable DIA range 0.081" to 0.180")
- TSK8003: Twist Strip Kit* with TSK8000 (M32610/01-24) w/All (10) 3 Conductor Die Sets (Cable DIA range 0.081" to 0.180")
- TSK8004: Twist Strip Kit* with TSK8000 w/All (9) 4 Conductor Die Sets (Cable DIA range 0.091" to 0.180")
- TSK8023: Twist Strip Kit* with TSK8000 (M32610/01-25) w/All (20) 2 & 3 Conductor Die Sets (Cable DIA range 0.081" to 0.180")

- TSK8500: Twist Strip Kit* with TSK8500 Only
- TSK8501: Twist Strip Kit* with TSK8500 w/All (13) 1 Conductor Die Sets (Cable DIA range 0.181" to 0.310")
- TSK8502: Twist Strip Kit* with TSK8500 w/All (13) 2 Conductor Die Sets (Cable DIA range 0.181" to 0.310")
- TSK8503: Twist Strip Kit* with TSK8500 w/All (13) 3 Conductor Die Sets (Cable DIA range 0.181" to 0.310")
- TSK8504: Twist Strip Kit* with TSK8500 w/All (13) 4 Conductor Die Sets (Cable DIA range 0.181" to 0.310")
- TSK8523: Twist Strip Kit* with TSK8500 w/All (26) 2 & 3 Conductor Die Sets (Cable DIA range 0.181" to 0.310")

*Includes case, TS8000-CIC or TS8500-CIC Cable Diameter Gauge Card, and accessories; in an organized, foam-lined insert. Individual die set part numbers are listed on page 7-8.



DIE SET CONTAINER



TSK8000 (KIT)
DIE SETS SOLD SEPARATELY



TSK8500 (KIT)
DIE SETS SOLD SEPARATELY

CABLE DIAMETER GAUGE CARD

First the user must determine the "lay" of the sample cable. See illustration on right. Universal dies are designed for cable with a left twist. Dies designed for cable with a right twist have an "R" in the part number:

TSRXXXX and TSLRXXXX. Certain applications may need a custom die set. If die sets above are not suitable, call DMC at (407) 855-6161 for assistance.

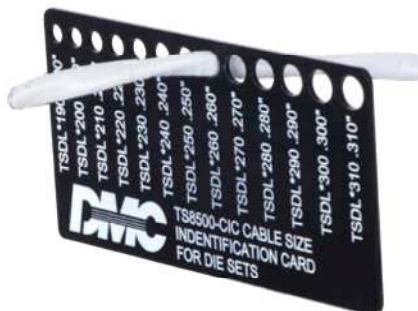

Cable Diameter Gauge Card
(TS8000-CIC/TS8500-CIC)

The Cable Diameter Gauge Card should be utilized to select a die set. The max OD and part number of the appropriate die set are shown next to each opening. Find the smallest opening in the gauge card that the cable freely passes through without getting snagged or stuck.

Select the corresponding die set to strip the selected cable.

NOTE: If the cable passes through the opening in the gauge card, but scrapes the sides of the ID of the opening or gets stuck, the user should select the next larger diameter die set.

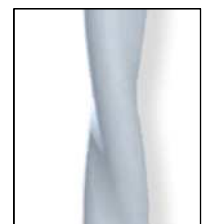

LEFT HAND LAY
"S" DIRECTION

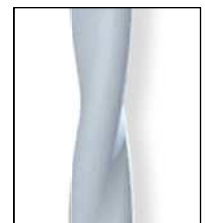

RIGHT HAND LAY
"Z" DIRECTION

Indent Crimp Tools

UPPER RANGE CRIMP TOOL AF8 M22520/1-01

The DMC **AF8**, qualified to MIL-DTL-22520/1 and AS22520/1, has virtually limitless application within the specified wire range of 12 through 26 AWG. Over one thousand turret heads are available to adapt the tool frame to your specific military or proprietary contact/wire combination. The 8 indent crimp, which is standard in the **AF8**, assures maximum mechanical and electrical strength in almost every closed barrel contact crimp. Special indent configurations and gaging are available upon request.

For proper operation, the tool must be mated with one of the following optional accessories: a military standard or non-military turret head (TH-XXX Part No. Series), a military standard or non-military positioner (TP-XXX Part No. Series), or an adjustable positioner** (Part No. UH2-5). This is done simply by orienting the head in the keyed position, and by tightening the hex socket screws provided as part of the head.

The precision ratchet controls cycling of the tool in both directions of handle movement. This assures the same accurate crimp every time. It's like having a quality control inspector at every work station.

Positive crimp depth is controlled by an 8 position selector knob conveniently located on the tool frame. The operator simply dials the desired step for the wire being used. This setting can be secured by use of a locking pin or safety wire.

The carefully engineered design achieves maximum mechanical advantage and the tool's light weight helps minimize operator fatigue.

A permanent dataplate is affixed to all turret heads and positioners. This plate lists specific contact part numbers, the corresponding position color code (for 3 position turret heads), and suggested selector depth settings for the wire size being used.

The adjustable head (P/N UH2-5) is ideally suited for lab work and prototype production applications. This head is attached in the same manner as explained above. The selected contact is inserted through the entry hole on the opposite side of the tool frame from the head. The height adjusting screw is then rotated until the contact is in the proper position for crimping. The screw can be secured with the locknut provided. Some testing will be necessary to determine the optimum selector setting for your contact/wire combination.

The **AF8** is approximately 9¾" x 2½" x 1¼" and weighs 15 oz.

CRIMP TOOLS WITH CYCLE COUNTERS

Most shops perform "GO/NO-GO" inspection on crimp tools after a specific period of time. But the usage of crimp tools in production or maintenance operations is inconsistent, and during a given period of time, a tool can be used to terminate thousands of wires, or less than a hundred, maybe none at all. Ideally, tools should be gaged based on actual usage and not a period of time.

In order to assist with this, DMC has designed a series of tools which are fitted with ruggedized Digital Cycle Counters. The Cycle Counter version of the **AF8** is the **AF8-CC**. Cycle Counters allow users to manage the tool through the inspection cycle based on the number of crimp cycles (actual usage) rather than an arbitrary time period. This greatly increases the number of crimp tools in production by decreasing the number of crimp tools awaiting gaging and balances the use of each tool between inspection events.

Each time the handles are closed, whether crimping a contact or just cycling the tool, the cycle is counted. Gage inspection is accomplished with common "GO/NO-GO" gage and the tool is returned to production.



**Adjustable positioner is not recommended for production operations

Indent Crimp Tools



GO GAGE



NO-GO GAGE

Other than keeping the unit clean and properly stored when not in service, no operator maintenance is required. DMC offers complete factory service by knowledgeable technicians within a reasonable turnaround time. Complete instructions concerning the use, care and warranty are supplied with each tool. Additional copies are available on request.

Pneumatic versions of this tool are found on pages 14-15.



The DMC1186 tool kit contains the AF8 tool frame, tool gage, and all mil-spec positioners and turret heads. Also included in the DMC1186 are tool instruction sheets and a tool selection chart.

Periodic gaging is recommended to insure accurate calibration. This can be done easily by setting the tool selector knob to position #4, and checking indenter closure with the M22520/3-1 "GO/NO-GO" gage (DMC part no. G125).

MILITARY P/N	DMC P/N	DESCRIPTION	NSN
M22520/1-01	AF8	TOOL FRAME	5120-01-335-8571
M22520/1-02	TH1A	TURRET	5120-01-335-8834
M22520/1-03	TH4	TURRET	5120-01-335-8835
M22520/1-04	TH163	TURRET	5120-01-335-8836
M22520/1-05	UH2-5	ADJUSTABLE POSITIONER*	5120-01-335-8583
M22520/1-06	TP45	POSITIONER	5120-01-335-8584
M22520/1-07	TP85	POSITIONER	5120-01-335-8585
M22520/1-08	TH199S	TURRET	5120-00-016-7654
M22520/1-09	TP360	POSITIONER	5120-01-335-8586
M22520/1-10	TP365	POSITIONER	5120-01-335-8587
M22520/1-11	TP465	POSITIONER	5120-01-335-8588
M22520/1-12	TH270	TURRET	5120-01-335-8838
M22520/1-13	TH285	TURRET	5120-01-036-9221
M22520/1-14	TH286	TURRET	5120-01-036-9222
M22520/1-15	TP485	POSITIONER	5120-01-335-8589
M22520/1-16	TP513	POSITIONER	5120-01-335-8590
M22520/1-17	TP651	POSITIONER	5120-01-335-8591
M22520/1-18**	TH343	TURRET	5120-01-361-9705
M22520/3-1	G125	GAGE	5220-01-016-6002
N/A	DMC1186	M22520/1 Tool Kit	N/A

*Adjustable positioner is not recommended for production operations

**QPL Pending



STEP 1
INSERT CONTACT



STEP 2
INSERT PRE-STRIPPED WIRE



STEP 3
CLOSE / OPEN HANDLE



STEP 4
REMOVE TERMINATED WIRE ASSEMBLY

Miniature Adjustable Crimp Tools

LOWER RANGE CRIMP TOOL AFM8 M22520/2-01

Qualified to MIL-DTL-22520/2 and AS22520/2, the DMC **AFM8** is designed for most of the miniature and sub-miniature connector types that are so widely used in electronic systems. The **AFM8** meets the need for a miniature tool accommodating wire sizes 20 through 32 AWG.

The **AFM8** gives a Mil-Standard 8 indent crimp, which assures maximum tensile and electrical strength. The cycle controlled precision ratchet assures consistently accurate crimps every time. The tool frame has a built-in 8 step selector knob for ease in dialing the correct crimp depth setting for the wire being used.

Positioners adapt the tool frame to a particular application. The data plate on each positioner designates which contacts the positioner accommodates for its wire size and indicates selector position. The positioner is easily removed and changed.

Periodic gaging is recommended to insure accurate calibration. This is easily accomplished with the M22520/3-1 "GO/NO-GO" gage (DMC part no. G125) on SEL setting #8. The **AFM8** is 6 3/4" in length and weighs approximately 10 oz.

Other than keeping the tool clean and properly stored when not in use, no operator maintenance is required. *Pneumatic versions of this tool are found on page 14-15.*

CRIMP TOOLS WITH CYCLE COUNTERS

DMC has designed a series of tools which are fitted with ruggedized Digital Cycle Counters. The Cycle Counter version of the AFM8 is the AFM8-CC. Cycle Counters allow users to manage the tool through the inspection cycle based on the number of crimp cycles (actual usage) rather than an arbitrary time period. This greatly increases the number of crimp tools in production by decreasing the number of crimp tools awaiting gaging and balances the use of each tool between inspection events.



MILITARY P/N	DMC P/N	DESCRIPTION	NSN
M22520/2-01	AFM8	TOOL FRAME	5120-01-335-8572
M22520/2-02	K1S	POSITIONER	5120-01-335-8592
M22520/2-03	K60S	POSITIONER	5120-01-335-8593
M22520/2-04	K151	POSITIONER	5120-01-335-8594
M22520/2-05	K3	POSITIONER	5120-01-335-8595
M22520/2-06	K41	POSITIONER	5120-01-335-8624
M22520/2-07	K40	POSITIONER	5120-01-335-8625
M22520/2-08	K13-1	POSITIONER	5120-01-335-8626
M22520/2-09	K42	POSITIONER	5120-01-335-8627
M22520/2-10	K43	POSITIONER	5120-01-335-8628
M22520/2-11	K287	POSITIONER	5120-01-335-8629
M22520/2-12	K286	POSITIONER	5120-01-335-8630
M22520/2-13	K338	POSITIONER	5120-01-335-8631
M22520/2-14	K340	POSITIONER	5120-01-335-8632
M22520/2-15	K341	POSITIONER	5120-01-335-8633
M22520/2-16	K339	POSITIONER	5120-01-335-8634
M22520/2-17	K342	POSITIONER	5120-01-335-8635
M22520/2-18	K343	POSITIONER	5120-01-335-8636
M22520/2-19	K330-2	POSITIONER	5120-01-335-8637
M22520/2-20	K331-2	POSITIONER	5120-01-335-8638
M22520/2-21	K332-2	POSITIONER	5120-01-335-8609
M22520/2-22	K212	POSITIONER	5120-01-335-8610
M22520/2-23	K267-1	POSITIONER	5120-01-335-8611
M22520/2-24	K75S-1	POSITIONER	5120-01-335-8612
M22520/2-25	K261-1	POSITIONER	5120-01-335-8613
M22520/2-26	K262-1	POSITIONER	5120-01-335-8614
M22520/2-27	K269-1	POSITIONER	5120-01-335-8615
M22520/2-28	K373-1	POSITIONER	5120-01-335-8616
M22520/2-29	K372-1	POSITIONER	5120-01-335-8617
M22520/2-30	K404	POSITIONER	5120-01-335-8618
M22520/2-31	K406	POSITIONER	5120-01-335-8619
M22520/2-32	K496	POSITIONER	5120-01-335-8620
M22520/2-33	K74S	POSITIONER	5120-01-335-8621
M22520/2-34	K323	POSITIONER	5120-01-335-8622
M22520/2-35	K532-1	POSITIONER	5120-01-335-8623
M22520/2-36	K473	POSITIONER	5120-01-335-8596
M22520/2-37	K709	POSITIONER	5120-01-361-9666
M22520/2-38**	K1561	POSITIONER	N/A
M22520/2-39**	K1430-1	POSITIONER	N/A
M22520/2-40**	K1457-1	POSITIONER	N/A
M22520/3-1	G125	GAGE	5220-01-016-6002
N/A	SK2/2*	ADJ. POSITIONER	5120-01-171-1569
N/A	DMC274	M22520/2 TOOL KIT	5180-01-259-0512

*Adjustable positioner is not recommended for production operations

**QPL Pending

Middle Range Adjustable Crimp Tools



MIDDLE RANGE INDENT CRIMP TOOL MH860 M22520/7-01

Qualified to MIL-DTL-22520/7 and AS22520/7, the DMC **MH860** is an addition to the military specification. It was developed to meet the demonstrated need for supporting the majority of electrical systems with one versatile crimp tool frame.

The **MH860** accepts the entire middle wire range of 16 through 28 AWG, with positioners which adapt it to virtually all applications consistent with others in the MIL-DTL-22520 family.

Pneumatic versions of this tool are found on pages 14-15.

The DMC123 tool kit contains the **MH860** tool frame, tool gage, and all mil-spec positioners. Also included in the DMC123 are tool instruction sheets and a tool selection chart.

MILITARY P/N	DMC P/N	DESCRIPTION	NSN
M22520/7-01	MH860	TOOL FRAME	5120-01-335-8573
M22520/7-02	86-1S	POSITIONER	5120-01-335-8597
M22520/7-03	86-2	POSITIONER	5120-01-335-8598
M22520/7-04	86-3	POSITIONER	5120-01-335-8599
M22520/7-05	86-4	POSITIONER	5120-01-335-8600
M22520/7-06	86-5	POSITIONER	5120-01-335-8601
M22520/7-07	86-6	POSITIONER	5120-01-335-8602
M22520/7-08	86-7	POSITIONER	5120-01-335-8603
M22520/7-09	86-11S	POSITIONER	5120-01-335-8604
M22520/7-10	86-12S	POSITIONER	5120-01-335-8605
M22520/7-11	86-19	POSITIONER	5120-01-335-8606
M22520/7-12	86-20	POSITIONER	5120-01-335-8607
M22520/7-13	86-21	POSITIONER	5120-01-335-8608
M22520/7-14**	86-30-1	POSITIONER	N/A
M22520/3-3	G145	GAGE	5120-00-338-0378
N/A	86-37	ADJUSTABLE POSITIONER*	N/A
N/A	DMC123	M22520/7 TOOL KIT	5180-01-355-5616

*Adjustable positioner is not recommended for production operations

**QPL Pending



DMC123 Tool Kit

CRIMP TOOLS WITH CYCLE COUNTERS

DMC has designed a series of tools which are fitted with ruggedized Digital Cycle Counters. The Cycle Counter version of the MH860 is the MH860-CC. Cycle Counters allow users to manage the tool through the inspection cycle based on the number of crimp cycles (actual usage) rather than an arbitrary time period. This greatly increases the number of crimp tools in production by decreasing the number of crimp tools awaiting gaging and balances the use of each tool between inspection events. See page 10 for more information.

MIL-DTL-28840 TOOLING PART NUMBERS			
MILITARY P/N	DMC P/N	DESCRIPTION	NSN
M22520/34-01	39-000	BASIC CRIMP TOOL	5120-01-242-3516
M22520/34-02	39-102	POSITIONER	5120-01-242-1041
M22520/35	G345	GAGE	5220-01-392-1065
M81969/33-01	DAK55-22SA	INST. TOOL (STRAIGHT)	5120-01-230-1506
M81969/33-02	DAK55-22JA	INST. TOOL (OFFSET)	5120-01-335-8666
M81969/34-01	DRK56-22A	REMOVAL TOOL	5120-01-230-1507
N/A	DMC782	MIL-C-28840 TOOL KIT	5180-01-363-1391

Pneumatic Indent Crimp Tools

PNEUMATIC INDENT CRIMP TOOLS

The DMC Pneumatic (Compressed Air Powered) Crimp tools **WA27F**, **WA22P** and **WA22** are direct equivalents of their corresponding hand tools. They use the same turret heads or positioners, gages and other accessories.

As production requirements grow, all that needs to be added is the tool frame itself. The resulting production capability can, in many instances, compare with an automated system costing thousands of dollars more.

These pneumatic tools are widely used in both military and proprietary programs. Their popularity has come about because of their unequalled reputation for trouble-free, dependable service, and their cost saving adaptability.

Whether upper, middle, lower, or mid-current range, the pneumatic tools fulfill the same precise crimp requirements as the hand models. They use the same indenter configuration, the same gaging dimensions and selector settings. No additional operator training is necessary. Accurate calibration is maintained by a unique 8 step machined steel block that holds gaging tolerances far longer than the usual adjustment screw method. This solid gaging means high output with less downtime.

The compact size and light weight of these tools allow them to be used easily as hand tools, as well as high production bench tools. The hand

trigger is designed for equal ease of use by right or left handed operators. Bench mounted, the optional foot valve allows hands-free operation. The bench mount will allow the tool to be secured at virtually any angle for individual comfort, thereby minimizing operator fatigue.

The Upper Range **WA27F** (equivalent to AF8) accommodates TH-xxx series turret heads or TP-xxx series positioners, length 10", diameter 2 3/4", weight 50 oz.

The Middle Range **WA22P** (equivalent to MH860) accommodates MIL-standard and commercial "86" series positioners, length 8", diameter 2 1/4", weight, 32 oz.

The Lower Range **WA22** (equivalent to AFM8) accommodates standard and commercial "K" series positioners, length 8", diameter 2 1/4", weight 32oz.

SIDE SELECT PNEUMATIC CRIMP TOOLS

DMC Pneumatic tools are often mounted on a Bench Mount, and some find it inconvenient to set or check the setting of the crimp depth selector when the tool is mounted for benchtop use. DMC resolved this issue by creating a version of the tool which moves the crimp depth selector to the side of the tool in a "looking up" position. These tools have the same crimp depth settings as the original tools, but with the knob in a more convenient position: Adding "SS" to the part number of the WA Series Pneumatic Crimp Tools will

apply to the Side-Select versions. A retro fit kit is also available for converting standard tools to Side Select tools.

CRIMP TOOLS WITH CYCLE COUNTERS

Most shops perform "GO/NO-GO" inspection on crimp tools after a specific period of time. But the usage of crimp tools in production or maintenance operations is inconsistent, and during a given period of time, a tool can be used to terminate thousands of wires, or less than a hundred, maybe none at all. Ideally, tools should be gaged based on actual usage and not a period of time.

In order to assist with this, DMC has designed a series of tools which are fitted with ruggedized Digital Cycle Counters that allow users to manage the tool through the inspection cycle based on the number of crimp cycles (actual usage) rather than an arbitrary time period. This greatly increases the number of crimp tools in production by decreasing the number of crimp tools awaiting gaging and balances the use of each tool between inspection events.

Each time the handles are closed, whether crimping a contact or just cycling the tool, the cycle is counted. Gage inspection is accomplished with common "GO/NO-GO" gage and the tool is returned to production.



Pneumatic Indent Crimp Tools

DMC PNEUMATIC TOOLS TO HAND TOOLS

MILITARY PART #*	DMC PART #	DESCRIPTION	COMPARABLE HAND TOOL DMC PART #	COMPARABLE HAND TOOL MILITARY PART #
M22520/28-01*	WA22	Indent Tool for Size 20-32 Wire	AFM8	M22520/2-01
	WA22CC	Cycle Counter WA22	AFM8	M22520/2-01
	WA22LC-X1	Smaller, lighter version for hand-held operation	AFM8	M22520/2-01
	WA22SS	Side Select WA22	AFM8	M22520/2-01
	WA22P	Indent Tool for Size 16-28 Wire	MH860	M22520/7-01
	WA22PSS	Side Select WA22P	MH860	M22520/7-01
	WA22H	Ultra Precision Tool for Size 20-32 Wire	MH800	
	WA22AE	Micro-Crimp Tool for Coax Inner Contacts	MH992	M22520/46-01
	WA22U	M28840 Connector Crimp Tool	39-000	
	WA27-300BT-EP	Indent Tool for Size 6-18 Wire	M300-BT	
M22520/29-01*	WA27F	Indent Tool for Size 12-26 Wire	AF8	M22520/1-01
	WA27FCC	Cycle Counter WA27F	AF8	M22520/1-01
	WA27FSS	Side Select WA27F	AF8	M22520/1-01
	WA27LH	Two Level Crimp Tool	LH8	
	WA27R	Outer Shield Crimp Tool (Size 12)	GS200-1	
	WA27T	Outer Shield Crimp Tool (Size 16)	GS100-1	

*Contact DMC for QPL status



WA27RF

WA27RF REGULATOR AND FILTER

Clean, consistent air pressure is required for precise tools in order to maintain their reliability and repeatability. It may require a regulator and filter in-line with the incoming compressed air supply. Multiple crimp tools can be attached to one regulator/air filter equipped line.

WA10A FOOT VALVE

The foot valve, when installed in-line with an air supply, makes a portable system which is adaptable to any work bench. Air supply requirements are 80-120 PSI (5.5 to 8.2 bar) clean dry air. The system uses standard air fittings readily available in most shops.



PNEUMATIC TOOL ACCESSORIES

MILITARY P/N*	DMC P/N	DESCRIPTION
M22520/30-01*	BM-2A	Bench Mount
M22520/30-02*	WA10A*	Foot Pedal
	WA27RF	Air Regulator and Filter
	WA27FSS-RK	Side-Select Conversion Kit for WA27F
	WA22SS-RK	Side-Select Conversion Kit for WA22

BM-2A BENCH MOUNT

The fully adjustable bench mount is compatible with most DMC power tools. The base measures 4" x 8" and can be used attached or unattached to the work surface.

WA22-LC-X1 HAND-HELD PNEUMATIC CRIMP TOOL

The same basic WA22 tool that is commonly bench mounted for first end terminations is available in a lighter, more ergonomic version for hand-held operation. The WA22-LC-X1 tool features a smaller profile and lighter weight which makes it especially useful for second end terminations on vertical and horizontal wiring form boards. Most size 20 and smaller contacts can be terminated with this tool.



BM-2A BENCH MOUNT



WA22-LC-X1

MIL Spec Circular Indent Crimp Tools

MODELS: MH801, MH802, MH803, MH804, GS100-1 & GS200-1



When special conditions call for a new tool design, we make every effort to utilize the components of existing tools which have been proven reliable both in field use and controlled test programs.

Such is the case with this tool series. The design of certain shielded contacts requires two additional crimping operations. One for the shield crimp sleeve, the other for the outer body. All of the tools give a concentric circular crimp configuration required by certain shielded contacts to insure compatibility with connector inserts and installing or removal tools in rear release applications, and/or maintain consistent electric impedance. Thus an indenter pattern which conforms to the appropriate military drawing (see chart for specific part numbers) was adapted to our familiar standard and miniature tool frames. (Note: On the MH801, MH802, MH803, and MH804 tools, in addition to the 4 opposing indenters, these tools also have 4 retainers which encompass the contact prior to the initiation of the crimping operation thus assuring concentricity.)

A full complement of positioners, inspection gages, and other accessories are available for these tool frames. The GS100-1 & GS200-1 tools are approximately 9 3/4" x 2 1/2" x 1 1/4" and weigh 15 oz each. The MH801, MH802, MH803, & MH804 tools are 6 3/4" in length and weigh approximately 10 oz each.

The technical section on pages 100 to 103 list the part numbers of standard M39029 contacts which require these tools; however, the concept may be adapted to other applications. Consult DMC for specific details.

Pneumatic versions of these tools are also available. Consult DMC for details.

MILITARY P/N	DMC P/N	DESCRIPTION	NSN	PURPOSE
M22520/4-01	GS100-1	TOOL FRAME	5120-01-335-8576	Outer Contact Size 16
M22520/4-02	GP295	POSITIONER	5120-01-335-8640	MIL-C-39029/76 Pin, /77 SOC, /78 SOC
	GS100	TOOL FRAME & POSITIONER		
M22520/3-2	G120	GAGE	5220-00-116-1911	
	WA27T	PNEUMATIC TOOL FRAME		Outer Contact Size 16
M22520/31-01	GS200-1	TOOL FRAME	5120-01-335-8577	Outer Contact Size 12
M22520/31-02	G2P330	POSITIONER	5120-01-416-4799	MIL-C-39029/27 SOC, /28 Pin, /75 SOC
	GS200	TOOL FRAME & POSITIONER	5120-00-117-4709	
M22520/3-15	G443	GAGE	5220-01-518-3433	
	WA27R	PNEUMATIC TOOL FRAME		Outer Contact Size 12
M22520/19-01	MH801	TOOL FRAME	5120-00-124-3490	Outer Contact Size 16
M22520/19-02	D16P-1M	POSITIONER	5120-00-124-3351	MIL-C-39029/19 Pin,
M22520/19-03	D16S-1M	POSITIONER	5120-00-124-3341	MIL-C-39029/21 SOC
M22520/19-04	D16LS-1M	POSITIONER	5120-01-335-8644	MIL-C-39029/20 SOC
M22520/3-4	G256	GAGE (INDENTERS)	--	
M22520/3-5	G257	GAGE (RETAINERS)	--	
M22520/20-01	MH802	TOOL FRAME	5120-00-124-3469	Shield Crimp Sleeve Size 16
M22520/20-02	D16/1-1M	POSITIONER	5120-00-124-3147	MIL-C-39029/19 Pin
M22520/20-03	D16/2-1M	POSITIONER	5120-00-124-3142	MIL-C-39029/20 SOC, 21 SOC
M22520/3-6	G258	GAGE (RETAINERS)	--	
M22520/21-01	MH803	TOOL FRAME	5120-00-124-3484	Outer Contact Size 12
M22520/21-02	D12P-1M	POSITIONER	5120-00-124-3381	MIL-C-39029/19 Pin
M22520/21-03	D12S-1M	POSITIONER	5120-00-124-3384	MIL-C-39029/21 SOC
M22520/21-04	D12LS-1M	POSITIONER	5120-00-124-3422	MIL-C-39029/20 SOC
M22520/3-7	G259	GAGE (RETAINERS)	--	
M22520/22-01	MH804	TOOL FRAME	5120-00-124-3487	Shield Crimp Sleeve Size 12
M22520/22-02	D12/1-1M	POSITIONER	5120-01-335-8650	MIL-C-39029/19 Pin, /21 SOC
M22520/22-03	D12/2-1M	POSITIONER	5120-00-124-3458	MIL-C-39029/20 SOC
M22520/3-8	G260	GAGE (RETAINERS)		

Circular Indent Crimp Tools

CIRCULAR CRIMP TOOLS

DMC manufactures a range of Circular Indent Crimp Tools used primarily for outer shield terminations in contacts. These tools are capable of crimping a circle as small as 0.040" and as large as 0.262". Due to the nature of crimping a complete circle, with 4 equal segments each tool is specified for a certain diameter. See the charts on this page for diameter sizes and part numbers.

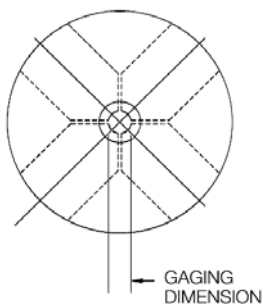

CIRCULAR INDENT CONFIGURATION

CIRCULAR CRIMP TOOLS BY CRIMP DIMENSION		
CIRCULAR CRIMP DIMENSION	TOOL P/N	GAGE
0.040-0.045"	GS216	G753
0.042-0.046"	GS210	G925
0.059-0.064"	GS211	G226
0.061-0.065"	GS205	G450
0.065-0.099"	GS8-3	G941
0.080-0.084"	GS212	G732
0.086-0.090"	GS225	G919
0.093-0.097"	GS221	G881
0.096-0.100"	GS222	G120
0.124-0.128"	GS223	G917
0.140-0.144"	GS226	G1056
0.142-0.146"	GS218	G443
0.154-0.158"	GS201	G446
0.156-0.160"	GS101	G445
0.167-0.171"	GS227	G1057
0.190-0.194"	GS219	G848
0.197-0.201"	GS208	G533
0.234-0.238"	GS213	G926
0.258-0.262"	GS206	G426

CIRCULAR CRIMP TOOLS BY PART NUMBER		
TOOL P/N	CIRCULAR CRIMP DIMENSION	GAGE
GS101	0.156-0.160"	G445
GS201	0.154-0.158"	G446
GS205	0.061-0.065"	G450
GS206	0.258-0.262"	G426
GS208	0.197-0.201"	G533
GS210	0.042-0.046"	G925
GS211	0.059-0.064"	G226
GS212	0.080-0.084"	G732
GS213	0.234-0.238"	G926
GS216	0.040-0.045"	G753
GS218	0.142-0.146"	G443
GS219	0.190-0.194"	G848
GS221	0.093-0.097"	G881
GS222	0.096-0.100"	G120
GS223	0.124-0.128"	G917
GS225	0.086-0.090"	G919
GS226	0.140-0.144"	G1056
GS227	0.167-0.171"	G1057
GS8-3	0.065-0.099"	G941



Special Application Indent Crimp Tools

Dedicated Application Circular Crimp Tools

DEDICATED APPLICATION CIRCULAR CRIMP TOOLS

Some of our Circular Crimp Tools already have turrets or positioners designed to accommodate common contacts. See the tool selection charts below:

DEDICATED APPLICATION CIRCULAR CRIMP TOOLS				
TOOL P/N	APPLICATION	CRIMP DIMENSION	GAGE	POSITIONERS AVAILABLE
GS100	Tyco, Amphenol, & Radiall Contacts (See Chart)	0.096-0.100"	G120	6
GS200	Amphenol/Bendix, Radiall, & Tri-Star Contacts (See Chart Below)	0.142-0.146"	G443	5
GS209	Amphenol Intermediate Contacts 21-33197-10, 21-33198-10	0.154-0.158"	G446	1
GS212	Amphenol & Sabritec Contacts (See Chart Below)	0.080-0.084"	G732	10
GS218	Amphenol Contacts 10-589514-126, NZGC-X50-12PB-5, NZGC-X50-12SB-5, NZGC-X75- 12PB-6, NZGC-X75-12SB-6	0.142-0.146"	G443	1
GS222	Positronic MC11NS, FC112N2S, FC112N2S-1565.0	0.096-0.100"	G120	1
GS223	Positronic FC610N2S, MC610NS, SK4195, SK4196	0.124-0.128"	G917	2
GS225	Amphenol 21-33908-29, 21-33909-29	0.086-0.090"	G919	1
GS227	Deutsch Contact 59155-000-Socket, 59155-000-Pin	0.167- 0.171"	G1057	1
GS2XE	Unstripped Wire End Caps Pneumatic Version: WA27XE-EP	0.123-0.129 0.134-0.140	G719	1
GS8-3	8 Step Tool	0.065-0.099"	G941	1

POSITIONER LIST FOR GS100

POSITIONER	CONTACT MFG. & P/N
GP1256	AMPHENOL 21-33655-5
GP295	SINGLE POSITIONER MIL-C-24308 OUTER PIN & SOC.
GP385	AMP P71-2979-3,4,5,6 , P71-2980-1,2
GP425	AMP P71-2979-3, 4, 5, 6 & P71-2980-1, 2
GP475	AMP P71-2979 , P71-2980
GP926	RADIALL EPX 617130, 617131, 617132, 617030, 617031, 617032

POSITIONER LIST FOR GS212

POSITIONER	CONTACT MFG. & P/N
GP1015	DEUTSCH 533 433-4
GP1120	AMPHENOL 21-33908-3 ASS'Y
GP1121	AMPHENOL 21-33909-3 ASS'Y
GP1243	AMPHENOL 21-33754-2
GP1613	AMPHENOL 21-33908-25 & 21-33909-25
TH553	Amphenol Intermediate Contacts L-38151-897, L-38151-907
TP1359	SABRITEC SL-10
TP1360	SABRITEC SL-12
TP1361	SABRITEC SL-14
TP1369	SABRITEC SL-16

POSITIONER LIST FOR GS200

POSITIONER	CONTACT MFG. & P/N
GP1596	TRI-STAR 317-16CX-091
GP1256	AMPHENOL 21-33655-5
GP781	INTERMEDIATE BRAID #10 TRIAXIAL CONTACT
GP926	RADIALL EPX 617130, 617131, 617132, 617030, 617031, 617032
G2P330	#12 BENDIX COAX GS200

POSITIONER LIST FOR GS223

POSITIONER	CONTACT MFG. & P/N
TP1386	POSITRONIC FC610N2S & MC610NS

POSITIONER LIST FOR GS222

POSITIONER	CONTACT MFG. & P/N
TP1366	POSITRONIC MC112NS; FC112N2S; FC112N2S-1565.0

POSITIONER LIST FOR GS209

POSITIONER	CONTACT MFG. & P/N
TH551	Amphenol 21-33197-10, 21-33198-10 Intermediate Contact

POSITIONER LIST FOR GS225

POSITIONER	CONTACT MFG. & P/N
GP1611	AMPHENOL 21-33908-29 & 21-33909-29

Special Application Indent Crimp Tooling

BIASED CRIMP TOOLS (MODELS SC8 & MH993)

Our Biased Crimp tools have a 4 indent pattern with flat-tipped indenters that are offset at an angle of 45 degrees to produce a radial or spiral pattern around the wire barrel, typically used with seamed or formed barrel contacts. This indent pattern is also useful for holding springs (or spring like devices) to a tube or solid rod. We offer two Biased Crimp tools, the SC8 for sizes 12 thru 26 AWG and the MH993 for 20 thru 32 AWG.

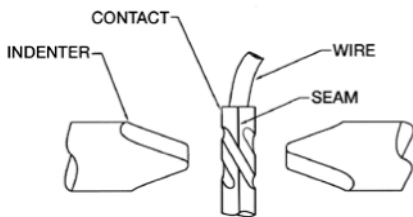

The model **SC8** has single flat-tipped indenters and accommodates wire sizes 12 thru 26 AWG (the miniature to sub-miniature range). It accommodates the TP series positioners and is easily identified by a distinctive black body and grey handle grip. It is 9¾" in length and weighs approximately 15 oz. Gaging is accomplished with the G125 "GO/NO-GO" gage.

The pneumatic power version of this tool is the WA27AJ.



The model **MH993** has double tipped indenters and accommodates wire sizes 20 thru 32 AWG (the miniature to sub-miniature range). It accommodates the K series positioners. It is 6¾" in length and weighs approximately 10 oz. Gaging is accomplished with the G125 "GO/NO-GO" gage.

The pneumatic power version of this tool is the WA22BC.

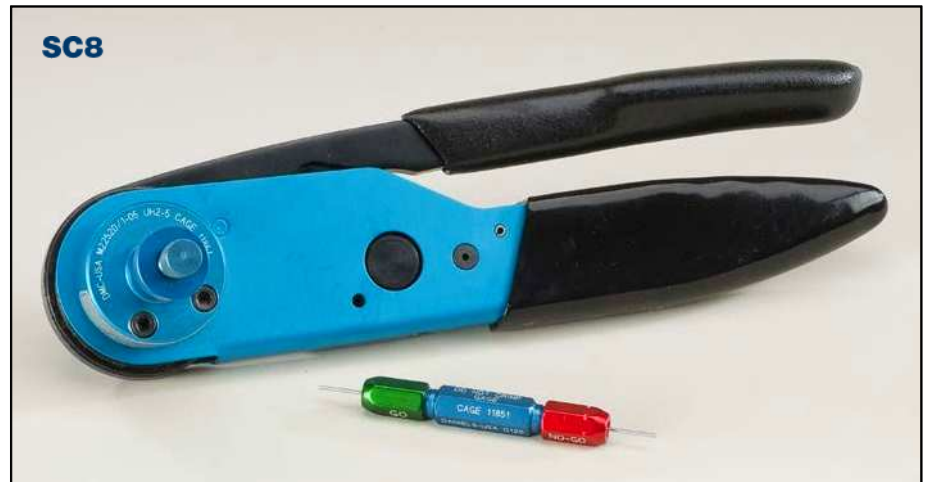

SC8 BIASED CRIMP TOOL		
DMC P/N	DESCRIPTION	PURPOSE
TP1189	POSITIONER	CONXALL 680-SG (SC8)
TP1190	POSITIONER	CONXALL 586-SG (SC8)
TP1191	POSITIONER	CONXALL 5053-20 GS (SC8)
TP1621	POSITIONER	CONXALL 587-PGN5 & 586-SUN
G125	GAGE	Go/No-Go Test for SC8



MH993 BIASED CRIMP TOOL		
DMC P/N	DESCRIPTION	PURPOSE
K1287S	POSITIONER	610-110-101 Virginia Panel
K1732	POSITIONER	587-PGN5 CONXALL
K1749	POSITIONER	587-PGN CONXALL
K1819	POSITIONER	41023-10G1-1 ICON SYSTEMS
G125	GAGE	Go/No-Go Test for MH993

Mid-Current Range Indent Crimp Tools



The M300BT is designed for pin and socket contacts, **AWG sizes 6-14**. This tool is available in a pneumatic version, P/N WA27-300BT-EP.

M300BT APPLICATIONS	
POSITIONER P/N	CONTACT MFG. & PART NUMBER
SP587	BURNDY RC14P1EOP1-RC12P1EOP1 & RC10P1EOP1
SP593	SOCAPEX CONTACTS-SOURIAU 8400 TOOL
SP604	DEUTSCH 047 1325 08 & 047 1326 08
SP708	DEUTSCH 1841-5-5608 & 18-007-08-9056
SP858	TYCO # 213552-2 2, 211161-1
TP1018	ROSEMONT SST SLEEVE
TP1029	(MAC MISSILE SYSTEMS) U.S. NAVY
TP1031	CROUSE HINDS 314263-110 PIN
TP1032	CROUSE HINDS 314262-110 SOC.
TP1033	BG SERVICE 22344-ASS'Y
TP1054	CROUSE HINDS A600568 MINI-CHANGE STYLE III, 600565
TP1055	CROUSE HINDS A600568 STYLE MINI-LINE, 600566 GRN PIN
TP1059	HARTING 09030006214, 09030006215
TP1060	CROUSE HINDS P1315209-270, -260, -250, -240, -230
TP1062	CROUSE HINDS P314262-150, -140, -130, -120
TP1064	CROUSE HINDS P1315366-130, -120, -110
TP1077	DELTA TECH SLEEVE STOP / COIL
TP1097	MULTI-CONTACT FRANCE 4FL 4 295 00
TP1111	AMPHENOL SOCAPEX 17DM53745-201, 17DM53744-201
TP1114	HYPERTRONICS YSK035-058GT
TP1151	TYCO 212007, 212008, 211159 & 211161
TP1159	RADIALL 616366

M300BT APPLICATIONS	
POSITIONER P/N	CONTACT MFG. & PART NUMBER
TP1169	BURNDY 82911679N
TP1188	AMPHENOL SOCAPEX 900198-91
TP1193	CKB S24923-000A3
TP1194	CKB S24924-000 A3
TP1222	WIELAND Z2 124 9521 0
TP1240	REF. FISCHER WIRE & PLASTIC
TP1286	MULTI-CONTACT 7-1261-01e & 7-2102-08
TP1318	SOURIAU 8902-210 & 8902-225
TP1378	CORY CMP004-103 & FCT FMP004-
TP1401	GAUTHIER G7500-P10-A0
TP1404	BURNDY 360J2224B7
TP714	SOURIAU 8476-28, 57888, 62622
TP799	8476-206
TP800	8476-207
TP823	RADIALL 282 551
TP826	ITT CANNON CDR897-0003, -0006
TP827	ITT CANNON CDR897-0004, -0007
TP852	CONTACT # E. F. JOHNSON P/N 12-2989-0528-7
TP870	ITT CANNON #031-0909-000, 031-0908-000
TP887	MULTI-CONTACT USA 05,0004
TP894	INTERCONNEXION CB-148-8-P, CD132-8-S
TP905	JUPITER M-8-MS, K-8-MS OCETA
TP907	AECMA EN3155-044, EN3155-045
TP908	FRB CONNECTRON 0350-24

M300BT APPLICATIONS	
POSITIONER P/N	CONTACT MFG. & PART NUMBER
TP910	FRB CONNECTRON 80-0200, 0200-47
TP916	SOURIAU 8819-118, 8819-119
TP924	SN 2377K100
TP927	LIVINGSTON 51469-1 (OCETA)
TP929	ELCON 702-31-01107
TP936	SOURIAU 8819-176 & -177
TP967	ITT CANNON 020436Y0000, 020437Y0000 SIZE 12
TP968	ITT CANNON 020434Y0000, 020435Y0000 SIZE 8 & 12
TP978	C.K.B. 0371-0004AS0, 0371-0003AS0
TP982	AMPHENOL 17-766-02
TP986	AIR LB P/N 001104-620 & 001104-630
TH558	BURNDY 3401040
TH579	Siemens Industrial Automation 6FX2003-5AA00 (Conductor) Siemens Industrial Automation 6FX2003-5AB00 (Insulation)
TH580	Siemens Industrial Automation 6FX2003-5AC00 (16 & 12 Conductor, Insulation)
TH581	Siemens Industrial Automation 6FX2003-5AD00 (Conductor, Insulation)
TH632	Siemens Industrial Automation 6FX2003-5AC00 (10 & 8 Conductor, Insulation)
TH640	Siemens Industrial Automation 6FX2003-4AB00 (Conductor, Insulation)
TH641	Siemens Industrial Automation 6FX2003-4AC00 (16 & 12 Conductor, Insulation)

Mid-Current Range Indent Crimp Tools



The **M309** is designed for pin and socket contacts, **AWG sizes 8-18**. This tool is available in pneumatic versions, P/Ns WA27-309-2C, WA27-309, WA27-309-EP.

M309 APPLICATIONS	
POSITIONER P/N	CONTACT MFG. & PART NUMBER
TP1014	REF EWC
TP1058	HARTING 09030006213
TP1061	CROUSE HINDS P1315209-210
TP1063	CROUSE HINDS P314262-110
TP1067	CROUSE HINDS 1463105-110, -120, 1463106-110, -120
TP1071	FCT FMP002P-, 002P-A, ETC.
TP1072	FMP002 & -, 002S-A, ETC.
TP1073	FCT FMP01-, FMP043S
TP1074	FCT FMP018S -, FMP043S
TP1075	FMP018P -, 043P
TP1087	CROUSE HINDS 600221
TP1094	TYCO 193796-1, 193797-1, 193841-1, 19382-1
TP1116	POSITRONIC *C4008D, *C4012D, *C4016D
TP1122	M50130A
TP1123	T & B 222-14-148 OR HARTING 0903006215
TP1124	TYCO 2-194035-2, -4, -5, -7, -8, & 3-19035-1, -0, -3
TP1125	TYCO 194032-5, -7
TP1132	SOURIAU 8291-1682, 8-1683N
TP1138	CONMED 20063
TP1141	NABSON 062095

M309 APPLICATIONS	
POSITIONER P/N	CONTACT MFG. & PART NUMBER
TP1150	MULTI-CONTACT 32-0100 & 32-0500
TP1152	ODU 345 24 2315 401
TP1156	BOSTON SCIENTIFIC Corporation BURNDY CONNECTOR
TP1164	SODERBER DS0009B
TP1179	HYPERTRONICS YPNO25-002G, YSK025-003AH, YPNO25-003G, YSK025-004AH
TP1214	TYCO 212007-1 / 212008-1
TP1221	TYCO 194245
TP1224	TYCO 212013-1 & 212014-1
TP1235	TYCO 194189
TP1244	GM POWERTRAIN SOCKET CONTACT
TP1247	TYCO 193846-1
TP1264	CONEC 610FET1A
TP1265	CONEC 610FET2A
TP1266	BURNDY JVSP00080B & JVSS00080B
TP1284	HYPERTRONICS YSK025-031 & YPNO25-024
TP1296	WIELAND Z2 124 9521 0
TP1317	GEOSERVICES 4805-136
TP1320	RETCONN 22-1013 & 22-1036



The **M300-25A** is designed for Amphenol-Sine Starline pin and socket contacts, **AWG sizes 10-18**. This tool is available in a pneumatic version, P/N

M300-25A APPLICATIONS	
POSITIONER P/N	CONTACT MFG. & PART NUMBER
TP682-1	PYLE NAT. # 16 & #18
TP683-1	PYLE NAT. #12 PINS
TP684-1	PYLE NAT. #10 P&S, & #12 SOCKETS

Mid-Current Range Adjustable Indent Crimp Tools



The **M310** is designed for pin and socket contacts, **AWG sizes 8-16** and has an enlarged crimp cavity to accommodate oversized contacts.

M310 APPLICATIONS	
POSITIONER P/N	CONTACT MFG. & PART NUMBER
TP1008	US AIR F18008-08-9056
TP1013	TYCO 193796-1, 193797-1, 193841-1, 193842-1
TP1019	TYCO 193837-1
TP1020	TYCO 193837-2, -3
TP1021	TYCO 193673-1
TP1022	TYCO 193673-2, -3
TP1030	3M CD353
TP1040	ARRAY 806-0598-000 & 857-0590-130
TP1041	ARRAY 806-0599-00A, -00B & 857-0591-130/A, -130/B
TP1042	ARRAY 806-0599-000 & 857-0591-130
TP1068	TYCO 193990 & 193991 TYPE XII ("S" REMOVED PER AMP)
TP1088	TYCO 193991-1 & -3 ("S" REMOVED PER AMP)
TP1154	REF. AC & E INDUSTRIES
TP1162	HYPERTRONICS YPN006-124H
TP1216	POSITRONIC INDUS.
TP1232	HYPERTRONICS YPN035-005, -006, -007, YSK035-009, -010, -011
TP792	HYPERTRONICS YPN015-031, YSK015-041
TP793	HYPERTRONICS YSK025-011 + -02, YPN025-009 + -010

OTHER MID-RANGE TOOLS

The **M316** is designed for crimping Sundstrand Aviation contacts #5905143 onto 16 AWG solid wire.

M310 APPLICATIONS	
POSITIONER P/N	CONTACT MFG. & PART NUMBER
TP802	FOR FRB CONTACTS 34-0300, 0300-12, 0300-17
TP806	FRB CONTACTS 0200-03, 0200-29, 0200-36 SOC.
TP807	FRB CONTACTS 31-0200, 58-0200, 64-0200 PIN
TP813	JUPITER CONTACTS BM-2611-5038ST-BF-201-150ST
TP814	FOR FRB CONTACT 29-0300
TP880	SMIT SLIKKERVEER #F-187306, #F-187307
TP890	FRB 0250-B-17G, -20G, 18-0250G, 20-0250G
TP891	FRB 13-0350G, 0350-B13G, 0350G, 0350-B-12G
TP902	HYPERTAC HST154 PIN, HST153 SOC
TP935	HYPERTRONICS YSK035-02G, ETC.
TP942	HYPERTRONICS YSK035-048
TP944	TYCO M310 USE TP944-1 WITH WA27-309-EP
TP965	FRB CONNECTRON 0300-20, 0300-24
TP974	POSITRONICS
TP999	CONNEL 16600,16601

The **M322** is designed for Therm-X Terminal Assembly (pin and socket) contacts.

The **M327** is designed for Greene Tweed 5672-1998 (pin and socket) contacts.



The **M321** is designed for the rail transportation industry.

M317 APPLICATIONS	
POSITIONER P/N	CONTACT MFG. & PART NUMBER
TP1002	CKB CC1000COM006, CC1000C0F006
TP1023	CKB SE0801-109 & SE0801-108
TP1024	CKB S24296-000B3 & S24263-000B3
TP1035	CKB S24265-000A3
TP1036	CKB S24298-000A3
TP1044	SOURIAU 8819-176, -177 (SIMILAR TP936 EXCEPT FOR M317)
TP1045	SOURIAU 8819-118, 8819-119
TP1052	BURNDY J383S1K-0006A01, J383P1K-0006A01
TP1065	CKB SE1239-007 (P), SE0692-130 (S)
TP1080	CKB 669-65 & 669-67
TP1131	AMPHENOL SOCAPEX 17DM53744-201, -206, -207, 17DM53745-201, -207, -208
TP1161	F.C.F. 10A-8638PPC100X, 10A-8638PSC100X, 20A-8638PPC200X, 20A-8638PSC200X, 40A-8638PPC400X, 40A-8638PSC400X
TP1163	FRB CONNECTRON 0200-47/80-0200
TP1338	CKB SOCKET CONTACT
TP1339	CKB PIN CONTACT
TP805	FRB CONTACTS 0350B11, -B12, -B13, 11-0350, 12-0350, 13-0350
TP909	FRB CONNECTRON 0200-42, 73-0200
TP911	FRB CONNECTRON 0300-21, 0300-17, 34-0300, 0300-23, 39-0300
TP912	FRB CONNECTRON 38 0300
TP957	HARTING 0932 000 6107, 6207, 6108, 6208
TP971	C.K.B. 0572-1016A4A



Mid-Current Range Adjustable Indent Crimp Tools

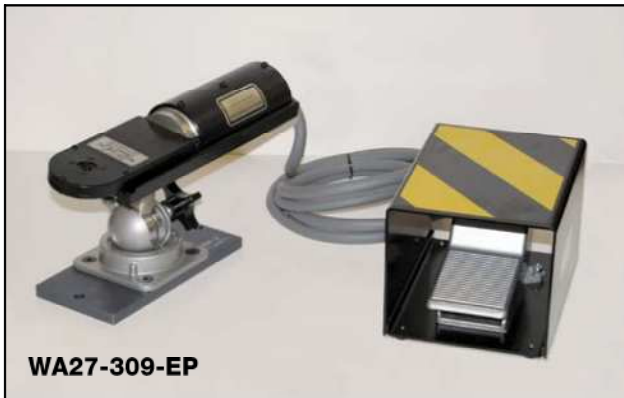

WA27-309-EP



WA27-300BT-EP



For power supply and power management applications, DMC offers our Industrial Mid-Current Range Adjustable Crimp Tools which have virtually limitless applications within the specified **wire range of 6 through 18 AWG**. The tools are used widely in the marine, rail, power generation, solar, and heavy transportation industries.

The Mid-Current Range Adjustable Crimp Tools are similar to our Standard Adjustable Indent Crimp Tool but have an enlarged crimp cavity to accommodate mid-current power contacts. Turret heads and positioners are available to adapt the tool frames to your specific contact/wire combination. The 8 impression crimp assures absolute maximum tensile strength with almost every closed barrel contact. Special indent configurations are available upon request.

For proper operation, the tool must be mated with a multi-position turret head (or a single-position positioner). These are attached by orienting the positioner in the keyed position and by tightening the hex socket screws provided as part of the positioner.

A permanent dataplate is affixed to all turret heads and positioners. This plate lists specific contact part numbers, the corresponding position color code (for 3 position turret heads), and suggested selector depth settings for the wire size being used.

On most models, crimp depth is controlled by a position selector knob located

on the tool frame. The operator simply dials the desired step for the wire being used. This setting can be secured by use of a locking pin or safety wire.

As with our Military Standard crimp tools, the cycle controlled ratchet assures a complete crimp every time. The carefully engineered design achieves the absolute maximum mechanical advantage.

Periodic gaging is recommended to insure accurate calibration. This can be done easily by setting the tool selector knob to the designated position and checking indenter closure with the "GO/NO-GO" gage designated for each tool.

These tools measure 9 $\frac{3}{4}$ " x 2 $\frac{1}{2}$ " x 1 $\frac{1}{4}$ " approximately and weighs less than a pound.

NOTE: Crimping wires and contacts in this range requires increased hand force in comparison with other common hand crimpers, therefore use of this hand tool should be limited to short run production and maintenance applications. There is a specified indenter closure that can be confirmed with the "GO/NO-GO" gage designated for each tool.

These tools measure 9 $\frac{3}{4}$ " x 2 $\frac{1}{2}$ " x 1 $\frac{1}{4}$ " approximately and weighs less than a pound.

MID-CURRENT RANGE PNEUMATIC TOOLS

WA27-300BT-EP is the pneumatic equivalent to the M300BT, length 15", diameter 2.75", weight 119 oz.

WA27-309-2C is the pneumatic equivalent to the M309, covering all 8 selector settings, length 12", diameter 2.75", weight 80 oz.

WA27-309 is the pneumatic equivalent to the M309, covering the lower 4 selector settings for AWG sizes 12-18, length 10", diameter 2.75", weight 50 oz.

WA27-309-EP is the pneumatic equivalent to the M309, with an extra pneumatic cylinder which provides more power for crimping the upper 4 selector settings for AWG sizes 8-14, length 15", diameter 2.75", weight 119 oz.



The **M320** is designed for Siemens Industrial Automation contacts, 6FX2003 Series. The M320 crimps both the conductor and the insulation. This tool is not available in a pneumatic version.

M320 APPLICATIONS

POSITIONER P/N	CONTACT MFG. & PART NUMBER
TH579-1	Siemens Industrial Automation 6FX2003-5AA00 (Conductor) Siemens Industrial Automation 6FX2003-5AB00 (Insulation)
TH580-1	Siemens Industrial Automation 6FX2003-5AC00 (12 & 16 Conductor, Insulation)
TH581-1	Siemens Industrial Automation 6FX2003-5AD00 (Conductor, Insulation)

Dedicated Application Indent Crimp Tooling

TWO-LEVEL INDENT CRIMP TOOL FOR BURNDY YHMM SERIES CONTACTS (MODEL LH8)

The **LH8** tool produces both conductor and insulation crimps simultaneously on Burndy YHMM series contacts used in many aircraft wiring systems (Boeing contact designations BACC47DE4 & BACC47DE5). It is functionally comparable to the Burndy M10S-1 crimp tool with S1 Die & SL-53 Stop Bushing (Combination).

The tool comes with a dedicated turret head positioner, LH281. It is gaged with gages G687 for the conductor & G743 for the insulation. The tool is approximately 9¾" x 2½" x 1¼" and weighs 15 oz. The pneumatic power version of this tool is the **WA27LH**.



MIL-C-22442/32-1 CLAMPING RING CRIMP TOOL

The **GS217** is designed to crimp clamping and retaining rings onto cable or wire in accordance with MIL-C-22442/32-1. The tool has 3 selector settings which crimp from 0.150 to 0.195". The tool is approximately 9¾" x 2½" x 1¼" and weighs 15 oz.

The pneumatic power version of this tool is the **WA27AD**. The assigned Turret Head is the **SH556** which accepts cable diameters from 0.110" to 0.195". Positioner **TP975** is also available to crimp Astrocom Electronics' Clamping Ring P/N 20822.



Other special indent tools are available, please consult DMC.

Special Application Indent Crimp Tooling

ULTRA PRECISION CRIMP TOOL (MODEL MH800)

All DMC tools are designed and built to the highest standards of precision and quality, but some applications call for more. One such case is contacts which have extremely thin wire barrel dimensions. The answer to this demand is the model **MH800** Ultra Precision Crimp Tool, which utilizes the same basic components as the Model AFM8 (M22520/2-01) Crimp Tool with tighter gaging tolerances and a special indenter tip configuration that assures a uniform flow of metal during the crimping operation.

The model **MH800** accommodates wire sizes 20 thru 32 AWG (the miniature to sub-miniature range). It accommodates the K series or M22520/2-XX positioners and is easily identified by a distinctive orange handle grip. It is 6¾" in length and weighs approximately 10 oz. Gaging is accomplished with the G100 "GO/NO-GO" gage. The pneumatic power version of this tool is the WA22H.



MH820 S5 STEEL INDENTER CRIMP TOOL

The **MH820** S5 Steel Indenter Crimp Tool is similar to the AFM8 miniature adjustable indent crimp tool.

The **MH820** has 8 crimp settings from 0.011" to 0.038" and is gaged with the G212 Go/No-Go gage. The tool is 6¾" in

length and weighs approximately 10 oz. The pneumatic power version of this tool is the WA22M.

MH800 POSITIONERS		
P/N	DESCRIPTION	PURPOSE
K4	POSITIONER	2202-16-0101 PIN, 2203-8-0101 PIN STK Deutsch
K5	POSITIONER	2202-17-0101 SOC, 2203-9-0101 SOC STK Deutsch
K30C	POSITIONER	TE/Deutsch Coax
K127	POSITIONER	2841-5-++00 RSM 2803-4-++00 RSM 100060-++TJ 2841-13-++00 RSM 2803-10-++00 RSM Deutsch
G100	GAGE	Go/No-Go Test for MH800

Other Positioners Available

MH820 POSITIONERS		
P/N	DESCRIPTION	PURPOSE
K277	POSITIONER	221-759P, 357-301-03 Amphenol
K1572SP	POSITIONER	582-110-2828 (Socket) Amphenol
K1573	POSITIONER	582-110-28283 Amphenol
K1740S	POSITIONER	ACB4P, ACB4S Center Contact Axon
G212	GAGE	Go/No-Go Test for MH820

Other Positioners Available

Special Application Indent Crimp Tooling

To keep pace with the most recent developments in technology, DMC is often called upon to custom engineer tooling for the medical, telecommunication, electronics, aerospace, and alternative energy industries. Some of these applications require unique indent configurations, special materials, and multi-stage crimp terminations. Some of the special application tools we've developed are listed on the following pages.

DMC is ready and capable to help satisfy your tooling needs with custom engineered tools and dies. Contact us with your requirements.

FINE TIPPED INDENTER TOOLS (MODELS MH835 & MH992)

The **MH835 & MH992** Fine Tipped Indenter tools are similar to the AFM8 miniature adjustable indent crimp tool, but have sharper indenter tips measuring .07 inches. The **MH835** tool produces a 4-indent crimp while the **MH992** tool produces an 8-indent crimp.

The **MH835** has 8 crimp settings from 0.0070" to 0.0330" and is gaged with the G619 Go/No-Go gage. The pneumatic power version of this tool is the **WA22BH**.

The **MH992** has 8 crimp settings from 0.0070" to 0.0330" and is gaged with the G822 Go/No-Go gage. The tool is 6¾" in length and weighs approximately 10 oz. The pneumatic power version of this tool is the **WA22AE**.

MH835 POSITIONERS		
P/N	DESCRIPTION	PURPOSE
K1618	POSITIONER	2999803003 Cinch
K1643	POSITIONER	B882D05 ATI
K1688S	POSITIONER	92286 NDC Nitinol
K1705	POSITIONER	D4601-L3 Signal Integrity
K1706	POSITIONER	E5656-H8 Signal Integrity
K1735S	POSITIONER	100.005.955 Kistler
K1754SP	POSITIONER	8300-0165 Ulti-Mate
K1761SP	POSITIONER	30/30/00/000 Glenair
K1762	POSITIONER	31/30/00/000 Glenair
G619	GAGE	Go/No-Go Test for MH835

Other Positioners Available

MH992 POSITIONERS		
P/N	DESCRIPTION	PURPOSE
K1072	POSITIONER	Tri-Tech
K1183S	POSITIONER	D1003, Eli Connectors
K1303S	POSITIONER	M39029/102-558 SKT TE Deutsch
K1304	POSITIONER	M39029/103-559 PIN TE Deutsch
K1360	POSITIONER	21-33664-7M, 21-33665-7M Amphenol
K1409	POSITIONER	Rosenberger
K1597	POSITIONER	Packets D-G Cook Inc
K1605	POSITIONER	6362-223-1231 Deutsch
K1624	POSITIONER	2999804004 Cinch
K1631	POSITIONER	6362-226-1231, 6362-227-1231 Deutsch
K1632	POSITIONER	Medical Implant Cochler
K1702S	POSITIONER	.028x.100LG Ferrule Accellent
K1704S	POSITIONER	#12 Quadrax Pin/Socket W. L. Gore & Assoc
K1709S	POSITIONER	3362-204-1231 Deutsch
K1721	POSITIONER	859-006 Glenair
K1730S	POSITIONER	857-000-280 Ultra Precision
K1733S	POSITIONER	3061-0-19-xx-21-xx10-0 Mill-Max
K1734S	POSITIONER	ETH4-0011A-D ETH4-0012A-D Souriau
K1739	POSITIONER	1996972-2 Tyco
K1744	POSITIONER	610870 Deutsch
K1751S	POSITIONER	TEM Samtec
K1752S	POSITIONER	C-295-XX-X Samtec
K1755	POSITIONER	1996972-2 Tyco
G822	GAGE	Go/No-Go Test for MH992

Other Positioners Available



TYPICAL CABLE CONNECTOR



CONTACT COLOR CODE AND BIN*

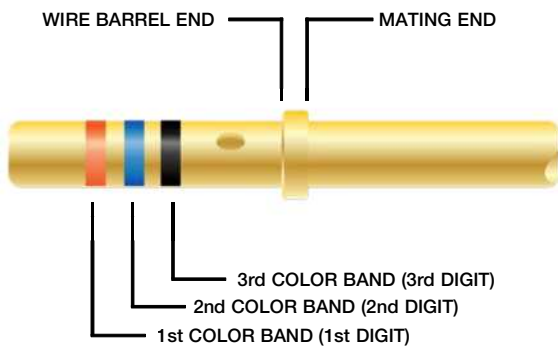

0 – Black (BLK)	5 – Green (GRE)
1 – Brown (BRN)	6 – Blue (BLU)
2 – Red (RED)	7 – Violet (VIO)
3 – Orange (ORN)	8 – Gray (GRA)
4 – Yellow (YEL)	9 – White (WHI)

*BASIC IDENTIFICATION NUMBER

- Example shown: 360 (Orange, Blue, Black)
- Manufacturers have the option of identifying contacts by stamping the BIN code on the shoulder or the wire barrel (size 16 and larger).

DISCLAIMER OF LIABILITY

The information contained in this [Tooling Guide for High-Reliability Wiring Systems](#) has been compiled by DMC from various sources, including its own documentation. It is presented as an aid to assist DMC's own customers and potential customers in selecting appropriate tooling for the assembly and maintenance of electrical wiring systems.

While DMC believes this information to be accurate, due to the complexity and volume of the information presented, DMC MUST AND DOES DISCLAIM ANY WARRANTY FOR ITS ACCURACY.

IN NO EVENT SHALL DMC BE LIABLE FOR CONSEQUENTIAL, INCIDENTAL, SPECIAL OR OTHER TYPES OF DAMAGES, LOSS OF ANTICIPATED PROFITS OR FOR ANY OTHER DAMAGES RESULTING FROM THE USE OF THE INFORMATION PRESENTED HEREIN.

M39029 Contact Quick Location Chart

CONTACT PART NUMBER	PAGE NUMBER	CONTACT PART NUMBER	PAGE NUMBER	CONTACT PART NUMBER	PAGE NUMBER	CONTACT PART NUMBER	PAGE NUMBER
M39029/1	58, 74	M39029/28 ¹	46, 66, 67, 68, 69, 70, 71, 72, 73	M39029/58	31, 40, 42, 43, 46, 47, 63, 66, 68, 70, 72, 106	M39029/90 ¹	43, 46, 47
M39029/2	55	M39029/29	50, 61, 106, 107	M39029/59 ¹	66, 67, 68, 69, 70, 71, 72, 73	M39029/91 ¹	46
M39029/3	55	M39029/30	50, 61, 106, 107	M39029/60 ¹	31	M39029/92	29
M39029/4	33, 57, 62, 63, 106	M39029/31	32, 34, 35, 39	M39029/63	31	M39029/93	60
M39029/5	29, 33, 57, 62, 63, 106	M39029/32	32, 34, 35, 39	M39029/64	31	M39029/94	60
M39029/6 ¹	CANCELED	M39029/33	51	M39029/65	CANCELED	M39029/95	60
M39029/7 ¹	33, 54, 57	M39029/34	36	M39029/66	CANCELED	M39029/96 ¹	60
M39029/8	33, 54, 57	M39029/35	36	M39029/68	CANCELED	M39029/97 ¹	60
M39029/9 ³	33, 54, 57	M39029/36	36	M39029/69	64	M39029/98 ¹	60
M39029/10 ³	54, 57	M39029/37	36	M39029/70	64	M39029/99 ¹	60
M39029/11	56, 106	M39029/38	CANCELED	M39029/71 ²	Wirewrap	M39029/100 ¹	60
M39029/12	56, 106	M39029/40	CANCELED	M39029/72 ²	Wirewrap	M39029/101	29
M39029/13 ¹	CANCELED	M39029/41	CANCELED	M39029/73 ¹	62	M39029/102 ¹	26, 40, 42, 43, 47, 84
M39029/14 ¹	CANCELED	M39029/42	CANCELED	M39029/74 ¹	40, 43, 47, 62	M39029/103 ¹	26, 40, 43, 47
M39029/15	CANCELED	M39029/43	CANCELED	M39029/75 ¹	40, 43, 46, 47	M39029/104 ¹	CANCELED
M39029/16	54	M39029/44	49, 65, 106, 107, 108	M39029/76 ¹	66, 67, 68, 69, 70, 71, 72, 73	M39029/105 ¹	CANCELED
M39029/17	53	M39029/45	49, 65, 106, 107, 108	M39029/77 ¹	40, 43, 47	M39029/106	CALL DMC
M39029/18	53, 54	M39029/46	52	M39029/78 ¹	66, 67, 68, 69, 70, 71, 72, 73	M39029/107	CALL DMC
M39029/19 ¹	53	M39029/47	51, 52	M39029/79 ¹	Inactive	M39029/108	CANCELED
M39029/20 ¹	53	M39029/48	30, 51, 101, 106	M39029/80 ¹	Inactive	M39029/109	CANCELED
M39029/21 ¹	82	M39029/49	30, 106	M39029/83	38	M39029/113	46, 66, 67, 68, 69, 70, 71, 72, 73
M39029/22	53, 54, 59	M39029/50 ¹	60, 61, 83	M39029/84	38	M39029/114	46, 66, 67, 68, 69, 70, 71, 72, 73
M39029/23 ¹	CALL DMC	M39029/51 ¹	60, 62, 83	M39029/85 ³	50, 59	M39029/117	41, 44, 48
M39029/24 ¹	CALL DMC	M39029/54 ¹	34, 83	M39029/86 ³	CALL DMC	M39029/118	41, 44, 48
M39029/25 ¹	32, 86	M39029/55 ¹	34, 83	M39029/87 ³	31, 40, 43, 47, 61	M39029/121	45
M39029/26 ¹	32	M39029/56	40, 43, 46, 47, 106	M39029/88 ³	40	M39029/122	45
M39029/27 ¹	66, 67, 70, 71, 72, 73	M39029/57	29, 31, 42, 63, 66, 68, 70, 72	M39029/89 ³	31, 42, 61		

¹shielded or coax/twinax
²not crimp barrel contacts

³thermocouple contacts
⁴contacts for relay socket — not a connector

QPL (Qualified Product List) sources listed in the following charts may change. Verify source QPL status at the following website: <https://www.navair.navy.mil/qpl/>

DMC does not provide connectors, contacts or wiring components. Parts shown here are for reference only. See disclaimer of liability on page 27.



MIL-DTL-12883

RELAY SOCKET

CONNECTOR P/N	DESCRIPTION	QPL SOURCES
M12883/40	RELAYS 4 POLE	AMPHENOL, CONNECTOR INDUSTRIES, DRI RELAYS, INC.
M12883/41	RELAYS 2 POLE	
M12883/44	RELAYS 4 POLE	
M12883/45	RELAYS 2 POLE	
M12883/46	RELAYS 3 POLE	
M12883/48	RELAYS 3 POLE	
M12883/50	RELAYS 2 POLE	
M12883/51	RELAYS 4 POLE	

CONTACTS	SIZE (AWG)		PIN/SKT.	PART NUMBER* (CURRENT)	PART NUMBER (SUPERSEDED)	WIRE RANGE
	MATING END	WIRE BARREL				
 <p>TYPICAL CONTACT CONFIGURATION</p>	16	16	S	M39029/5-116	M39029/5-16-16	16-20
	16	20	S	M39029/5-117	M39029/5-16-20	20-24
	12	12	S	M39029/5-118	M39029/5-12-12	12-14
	22	22	S	M39029/57-356	MS27491-22	22-26
	20	20	S	M39029/57-357	MS27491-20	20-24
	16	16	S	M39029/57-358	MS27491-16	16-20
	22	22	S	M39029/92-531	--	22-28
	20	20	S	M39029/92-532	--	20-24
	16	16	S	M39029/92-533	--	16-20
	16	20	S	M39029/92-534	--	20-24
	12	12	S	M39029/92-535	--	12-14
	22	22	S	M39029/101-552	--	22-28
	20	20	S	M39029/101-553	--	20-24
	16	16	S	M39029/101-554	--	16-20

TOOL SELECTION		CRIMP TOOL AND ACCESSORY					ASSEMBLY TOOLS	
BIN*	COLOR	AF8	AFM8	MH860	WA23 (POS)	WA23 (DIE)	INSTALLING	REMOVAL
116	BROWN-BROWN-BLUE	TH1A		86-2			DAK83-16B	DRK83-16B
117	BROWN-BROWN-VIOLET	TH1A		86-2			DAK83-16B	DRK83-16B
118	BROWN-BROWN-GRAY	TH1A					DAK83-12B	DRK83-12B
356	ORANGE-GREEN-BLUE		K41	86-5			DAK95-22B	DRK95-22B
357	ORANGE-GREEN-VIOLET	TH163	K43	86-7			DAK95-20B	DRK95-20B
358	ORANGE-GREEN-GRAY	TH163		86-3			DAK95-16B	DRK95-16B
531	GREEN-ORANGE-BROWN		K1561				DAK95-22B	DRK95-22B
532	GREEN-ORANGE-RED	TH1A					DAK95-20B	DRK95-20B
533	GREEN-ORANGE-ORANGE	TH1A		86-2			DAK95-16B	DRK95-16B
534	GREEN-ORANGE-YELLOW	TH1A		86-2			DAK95-16B	DRK95-16B
535	GREEN-ORANGE-GREEN	TH1A					DAK95-12B	DRK95-12B
552	GREEN-GREEN-RED	K330-3		86-19			81515-23	81515-23
553	GREEN-GREEN-ORANGE	TH343		86-20			81515-23	81515-23
554	GREEN-GREEN-YELLOW			86-21			81515-23	81515-23

*The three number suffix on M39029 series contacts is referred to as a "BIN" code. See page 27 for color stripe association.
 DMC does NOT provide connectors, contacts, or wiring components. Parts are shown here for reference only.

MIL-DTL-22992 CLASS L

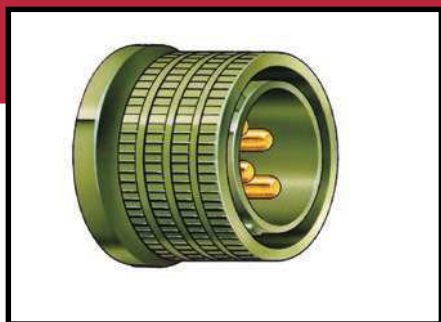

CIRCULAR HEAVY DUTY FRONT RELEASE CONTACTS

CONNECTOR P/N	DESCRIPTION	QPL SOURCES
MS90555	WALL MOUNT RECEPTACLE	AMPHENOL, SPACECRAFT COMPONENTS, SPI, LEXTEM3 SYSTEMS, ROBERT TECHNOLOGIES
MS90556	STRAIGHT PLUG	
MS90557	IN-LINE RECEPTACLE	
MS90558	WALL MOUNT PLUG	

CONTACTS	SIZE (AWG)		PIN/SKT.	PART NUMBER (CURRENT)	PART NUMBER (SUPERSEDED)	WIRE RANGE	
	MATING END	WIRE BARREL					
	6	6	P	M39029/48-317	MS90559-11	6	
	6N	6	P	M39029/48-318	MS90559-12	6	
	6G	6	P	M39029/48-319	MS90559-14	6	
	6	6	S	M39029/49-329	MS90560-7	6	
	6G	6	S	M39029/49-330	MS90560-8	6	
	4	4	P	M39029/48-320	MS90559-8	4	
	4N	4	P	M39029/48-321	MS90559-9	4	
	4G	4	P	M39029/48-322	MS90559-13	4	
	4	4	S	M39029/49-331	MS90560-5	4	
	4G	4	S	M39029/49-332	MS90560-9	4	
	0	0	P	M39029/48-323	MS90559-5	0	
	0N	0	P	M39029/48-324	MS90559-6	0	
	0	0	S	M39029/49-333	MS90560-3	0	
	2/0	2/0	P	M39029/48-325	MS90559-3	2/0	
	2/0N	2/0	P	M39029/48-326	MS90559-3	2/0	
	2/0	2/0	S	M39029/49-334	MS90560-2	2/0	
	4/0	4/0	P	M39029/48-327	MS90559-1	4/0	
	4/0N	4/0	P	M39029/48-328	MS90559-2	4/0	
	TYPICAL CONTACT CONFIGURATION	4/0	4/0	S	M39029/49-335	MS90560-1	4/0

TOOL SELECTION		CRIMP TOOL AND ACCESSORY					ASSEMBLY TOOLS	
BIN*	COLOR	AF8	AFM8	MH860	WA23 (POS)	WA23 (DIE)	INSTALLING	REMOVAL
317	Orange-Brown-Violet				WA23-10	WA23-3	NONE REQ.	DRK178-6A
318	Orange-Brown-Gray				WA23-10	WA23-3	NONE REQ.	DRK178-6A
319	Orange-Brown-White				WA23-10	WA23-3	NONE REQ.	DRK178-6A
329	Orange-Red-White				WA23-10	WA23-3	NONE REQ.	DRK178-6A
330	Orange-Orange-Black				WA23-10	WA23-3	NONE REQ.	DRK178-6A
320	Orange-Red-Black				WA23-12	WA23-4	NONE REQ.	DRK178-5A
321	Orange-Red-Brown				WA23-12	WA23-4	NONE REQ.	DRK178-5A
322	Orange-Red-Red				WA23-12	WA23-4	NONE REQ.	DRK178-5A
331	Orange-Orange-Brown				WA23-12	WA23-4	NONE REQ.	DRK178-5A
332	Orange-Orange-Red				WA23-12	WA23-4	NONE REQ.	DRK178-5A
323	Orange-Red-Orange				WA23-14	WA23-5	NONE REQ.	DRK178-3A
324	Orange-Red-Yellow				WA23-14	WA23-5	NONE REQ.	DRK178-3A
333	Orange-Orange-Orange				WA23-15	WA23-5	NONE REQ.	DRK178-3A
325	Orange-Red-Green				WA23-15	WA23-6	NONE REQ.	DRK178-2A
326	Orange-Red-Blue				WA23-15	WA23-6	NONE REQ.	DRK178-2A
334	Orange-Orange-Yellow				WA23-15	WA23-6	NONE REQ.	DRK178-2A
327	Orange-Red-Violet				WA23-16	WA23-7	NONE REQ.	DRK178-1A
328	Orange-Red-Gray				WA23-16	WA23-7	NONE REQ.	DRK178-1A
335	Orange-Orange-Green				WA23-16	WA23-7	NONE REQ.	DRK178-1A

*The three number suffix on M39029 series contacts is referred to as a "BIN" code. See page 27 for color strip association.

DMC does not provide connectors, contacts or wiring components. Parts shown here are for reference only. See disclaimer of liability on page 27.

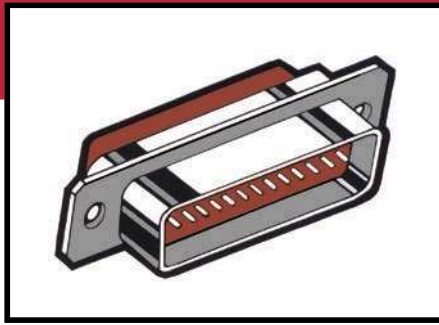

MIL-DTL-24308

MINIATURE RECTANGULAR RACK AND PANEL REAR RELEASE CONTACTS

CONNECTOR P/N	DESCRIPTION	QPL SOURCES
M24308/2	POLARIZED SHELL SOCKET CONTACTS	ADI ELECTRONICS, AMPHENOL, C&K COMPONENTS SAS, CINCH CONNECTOR, CRISTEK INTERCONNECTS, ITT Cannon, POSITRONIC INDUSTRIES, SOURIAU, TE CONNECTIVITY, GLENAIR, CONTINENTAL - WIRT
M24308/4	POLARIZED SHELL PIN CONTACTS	
M24308/6	POLARIZED SHELL SOCKET CONTACTS NON-MAGNETIC	
M24308/8	POLARIZED SHELL PIN CONTACTS NON-MAGNETIC	

CONTACTS	SIZE (AWG)		PIN/SKT.	PART NUMBER* (CURRENT)	PART NUMBER (SUPERSEDED)	WIRE RANGE
	MATING END	WIRE BARREL				
<p>TYPICAL CONTACT CONFIGURATION</p>	22	22D	P	M39029/58-360	M24308/11-1	20-24
	22	22D	S	M39029/57-354	M24308/10-1	20-24
	22	22D	S	M39029/58-986	N/A	
	22	22D	P	M39029/57-982	N/A	
	20	20	P	M39029/64-369	M24308/13-1	22-28
	20	20	S	M39029/63-368	M24308/12-1	22-28
	20	20	P	M39029/63-928	N/A	
	20	20	S	M39029/63-968	N/A	

TOOL SELECTION		CRIMP TOOL AND ACCESSORY					ASSEMBLY TOOLS	
BIN*	COLOR	AF8	AFM8	MH860	WA23 (POS)	WA23 (DIE)	INSTALLING	REMOVAL
968	WHITE-BLUE-GRAY	TP585	K13-1	86-30-1			DAK145 or M81969/1-02	DRK145 or M81969/1-02
369	ORANGE-BLUE-WHITE	TP585	K13-1	86-30-1				
368	ORANGE-BLUE-GRAY	TP585	K13-1	86-30-1				
928	WHITE-RED-GRAY	TP585	K13-1	86-30-1				
982	WH E-GRAY-RED		K42	86-6			DAK95-22MB or M81969/1-04	DRK95-22MB or M81969/1-04
360	ORANGE-BLUE-BLACK		K41	86-5				
354	ORANGE-GREEN-YELLOW		K42	86-6				
986	WHITE-RED-GRAY		K41	86-5				

*The three number suffix on M39029 series contacts is referred to as a "BIN" code. See page 27 for color stripe association.

Contact M39029/59-366 (Shielded Socket) #8 cavity, see page 88.

Contact M39029/60-367 (Shielded Pin) #8 cavity, see page 88.

Contact M39029/87 is a Thermocouple.

Contact M39029/89 is a Thermocouple.

NOTE: M24308/1, /3, /5, /7, /9, /23, /24, /27, /28, /29, /30, /31, /32, /33, /34, /35, /36, /37, /38, /39 & /40 are not crimp termination connectors. Use connector manufacturer instructions for assembly. M24308/25 & /26 are standards for mounting hardware.

DMC does NOT provide connectors, contacts, or wiring components. Parts are shown here for reference only.

MIL-DTL-26482 SERIES 1



CIRCULAR BAYONET COUPLING FRONT RELEASE CONTACTS

CONNECTOR P/N	DESCRIPTION	QPL SOURCES
MS3120	WALL MOUNT FLANGE RECEPTACLE	AMPHENOL, ARRAY CONNECTORS, BURNDY, ITT Cannon, VEAM, GLENAIR, TE CONNECTIVITY, CORSAIR, SOURIAU, CINCH
MS3121	CABLE CONNECTING PLUG	
MS3122	BOX MOUNT FLANGE RECEPTACLE	
MS3124	JAM NUT REAR MOUNT RECEPTACLE	
MS3126	STRAIGHT PLUG	
MS3127	BOX MOUNT FLANGE RECEPTACLE	
MS3128	WALL MOUNT FLANGE RECEPTACLE	

CONTACTS	SIZE (AWG)		PIN/SKT.	PART NUMBER* (CURRENT)	PART NUMBER (SUPERSEDED)	WIRE RANGE
	MATING END	WIRE BARREL				
	12	12	P	M39029/31-234 M39029/32-253	MS3192-12-12A MS3193-12-12A	12-14 12-14
	12	12	S			
	16	16	P	M39029/31-228 M39029/32-247	MS3192-16-16A MS3193-16-16A	16-20 16-20
	16	16	S			
TYPICAL CONTACT CONFIGURATION	20	20	P	M39029/31-240 M39029/32-259	MS3192-20A-20A MS3193-20A-20A	20-24 20-24
	20	20	S			

TOOL SELECTION		CRIMP TOOL AND ACCESSORY					ASSEMBLY TOOLS	
BIN*	COLOR	AF8	AFM8	MH860	WA23 (POS)	WA23 (DIE)	INSTALLING	REMOVAL
234	RED-ORANGE-YELLOW	TH1A					DAK12B	DRK12B
253	RED-GREEN-ORANGE	TH1A					DAK12B	DRK12B
228	RED-RED-GRAY	TH1A		86-2			DAK16B	DRK16B
247	RED-YELLOW-VIOLET	TH1A		86-2			DAK16B	DRK16B
240	RED-YELLOW-BLACK	TH1A	K1S	86-1S			DAK20B**	DRK20B
259	RED-GREEN-WHITE	TH1A	K1S	86-1S			DAK20B**	DRK20B

*The three number suffix on M39029 series contacts is referred to as a "BIN" code. See page 27 for color strip association.

Contact M39029/25-204 to 206 (Shielded Pin) #12 cavity, see page 86.

Contact M39029/26-207 to 209 (Shielded Socket) #12 cavity, see page 87.

DMC does not provide connectors, contacts or wiring components. Parts shown here are for reference only. See disclaimer of liability on page 27.

MIL-DTL-26482 SERIES 2

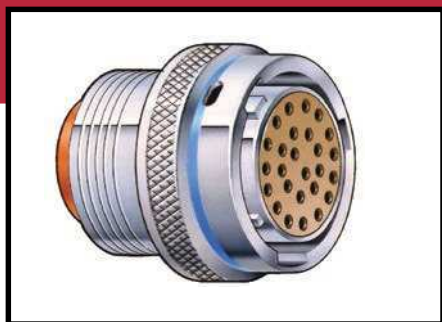

CIRCULAR BAYONET COUPLING REAR RELEASE CONTACTS

CONNECTOR P/N	DESCRIPTION	QPL SOURCES
MS3470	WALL MOUNT FLANGE RECEPTACLE	AERO ELECTRIC, AMPHENOL, TE/DEUTSCH, ITT Cannon, HERMETIC SEAL CORPORATION, FCI FRAMATONE GROUP
MS3471	CABLE CONNECTING PLUG	
MS3472	WIDE FLANGE WALL MOUNT RECEPTACLE	
MS3474	JAM NUT REAR MOUNT RECEPTACLE	
MS3475	PLUG RFI	
MS3476	STRAIGHT PLUG	

CONTACTS	SIZE (AWG)		PIN/SKT.	PART NUMBER* (CURRENT)	PART NUMBER (SUPERSEDED)	WIRE RANGE
	MATING END	WIRE BARREL				
<p>TYPICAL CONTACT CONFIGURATION</p>	12	12	P	M39029/4-113	M39029/4-12-12	12-14
	12	12	S	M39029/5-118	M39029/5-12-12	12-14
	12	16	P	M39029/4-114	M39029/4-12-16	16-20
	12	16	S	M39029/5-119	M39029/5-12-16	16-20
	16	16	P	M39029/4-111	M39029/4-16-16	16-20
	16	16	S	M39029/5-116	M39029/5-16-16	16-20
	16	20	P	M39029/4-112	M39029/4-16-20	20-24
	16	20	S	M39029/5-117	M39029/5-16-20	20-24
	20	20	P	M39029/4-110	M39029/4-20-20	20-24
	20	20	S	M39029/5-115	M39029/5-20-20	20-24

TOOL SELECTION		CRIMP TOOL AND ACCESSORY					ASSEMBLY TOOLS	
BIN*	COLOR	AF8	AFM8	MH860	WA23 (POS)	WA23 (DIE)	INSTALLING	REMOVAL
113	BROWN-BROWN-ORANGE	TH1A					DAK83-12B	DRK83-12B
118	BROWN-BROWN-GRAY	TH1A					DAK83-12B	DRK83-12B
114	BROWN-BROWN-YELLOW	TH1A		86-2			DAK83-12B	DRK83-12B
119	BROWN-BROWN-WHITE	TH1A		86-2			DAK83-12B	DRK83-12B
111	BROWN-BROWN-BROWN	TH1A		86-2			DAK83-16B	DRK83-16B
116	BROWN-BROWN-BLUE	TH1A		86-2			DAK83-16B	DRK83-16B
112	BROWN-BROWN-RED	TH1A		86-2			DAK83-16B	DRK83-16B
117	BROWN-BROWN-VIOLET	TH1A		86-2			DAK83-16B	DRK83-16B
110	BROWN-BROWN-BLACK	TH1A	K1S	86-1S			DAK83-20B	DRK83-20B
115	BROWN-BROWN-GREEN	TH1A	K1S	86-1S			DAK83-20B	DRK83-20B

*The three number suffix on M39029 series contacts is referred to as a "BIN" code. See page 27 for color stripe association.

Contact M39029/7-126 to 128 (Shielded Pin) #12 cavity, see page 86.

Contact M39029/8-129 to 131 (Shielded Socket) #12 cavity, see page 86.

Contact M39029/9-132 to 136 (Thermocouple Pin) #20 cavity, see page 86.

DMC does not provide connectors, contacts or wiring components. Parts shown here are for reference only. See disclaimer of liability on page 27.

MIL-DTL-26500



CIRCULAR THREADED OR BAYONET COUPLING FRONT RELEASE CONTACTS

CONNECTOR P/N	DESCRIPTION	QPL SOURCES
MS24264	FLANGE MOUNT RECEPTACLE	AMPHENOL, BOEING (SPECIFICATION), CINCH, CONNECTOR INDUSTRIES, DETORONICS, Deutsch/TE, ELECTRONIC SEALS, GLASSEAL, HERMETIC SEAL Corporation, ITT Cannon, SEALTRON, SOURIAU
MS24265	SINGLE HOLE MOUNT RECEPTACLE	
MS24266	STRAIGHT PLUG	
MS27613	WALL MOUNT RECEPTACLE	
MS27614	JAM NUT	
MS27615	PLUG	

CONTACTS	SIZE (AWG)		PIN/SKT.	PART NUMBER* (CURRENT)	PART NUMBER (SUPERSEDED)	WIRE RANGE
	MATING END	WIRE BARREL				
 TYPICAL CONTACT CONFIGURATION	12	12	P	M39029/31-235	MS24254-12P	12-14
	12	12	S	M39029/32-254	MS24255-12S	12-14
	16	16	P	M39029/31-229	MS24254-16P	16-20
	16	16	S	M39029/32-248	MS24255-16S	16-20
	20	20	P	M39029/31-627	MS39029/31-241	20-24
	20	20	S	M39029/32-260	MS24255-20S	20-24

TOOL SELECTION		CRIMP TOOL AND ACCESSORY					ASSEMBLY TOOLS	
BIN*	COLOR	AF8	AFM8	MH860	WA23 (POS)	WA23 (DIE)	INSTALLING	REMOVAL
235	RED-ORANGE-GREEN	TH1A					DAK12B	DRK12B
254	RED-GREEN-YELLOW	TH1A					DAK12B	DRK12B
229	RED-RED-WHITE	TH1A		86-2			DAK16B	DRK16B
248	RED-YELLOW-GRAY	TH1A		86-2			DAK16B	DRK16B
627	BLUE-RED-VIOLET	TH1A	K1S	86-2			DAK20B	DRK20B
260	RED-BLUE-BLACK	TH1A	K1S	86-2			DAK20B	DRK20B

*The three number suffix on M39029 series contacts is referred to as a "BIN" code. See page 27 for color stripe association.

Contact M39029/54-342 (Shielded Pin) #12 cavity, see page 87.

Contact M39029/54-343 (Shielded Pin) #8 cavity, see page 87.

Contact M39029/55-344 (Shielded Socket) #12 cavity, see page 87.

Contact M39029/55-345 (Shielded Socket) #8 cavity, see page 87.

DMC does not provide connectors, contacts or wiring components. Parts shown here are for reference only. See disclaimer of liability on page 27.

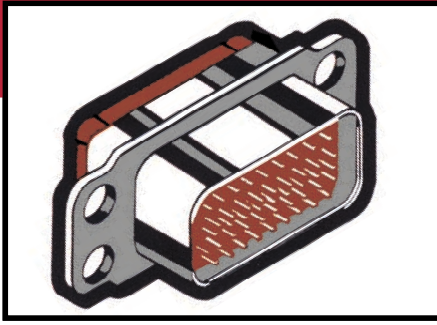

MIL-DTL-26518

CLASS R (INACTIVE, REFER TO MIL-DTL-83733)

MINIATURE RECTANGULAR RACK AND PANEL FRONT RELEASE CONTACTS

CONNECTOR P/N	DESCRIPTION	QPL SOURCES
M24285	RECEPTACLE	NO CURRENT QPL
M24286	PLUG	

CONTACTS	SIZE (AWG)		PIN/SKT.	PART NUMBER* (CURRENT)	PART NUMBER (SUPERSEDED)	WIRE RANGE
	MATING END	WIRE BARREL				
 TYPICAL CONTACT CONFIGURATION	12	12	P	M39029/31-235	MS24254-12P	12-14
	12	12	S	M39029/32-254	MS24255-12S	12-14
	16	16	P	M39029/31-229	MS24254-16P	16-20
	16	16	S	M39029/32-248	MS24255-16S	16-20
	20	20	P	M39029/31-241	MS24254-20P	20-24
	20	20	S	M39029/32-260	MS24255-20S	20-24

TOOL SELECTION		CRIMP TOOL AND ACCESSORY					ASSEMBLY TOOLS	
BIN*	COLOR	AF8	AFM8	MH860	WA23 (POS)	WA23 (DIE)	INSTALLING	REMOVAL
235 254	RED-ORANGE-GREEN RED-GREEN-YELLOW	TH1A TH1A					DAK12B DAK12B	DRK12B DRK12B
229 248	RED-RED-WHITE RED-YELLOW-GRAY	TH1A TH1A		86-2 86-2			DAK16B DAK16B	DRK16B DRK16B
241 260	RED-YELLOW-BROWN RED-BLUE-BLACK	TH1A TH1A	K1S K1S	86-1S 86-1S			DAK20B DAK20B	DRK20B DRK20B

TOOL SELECTION		CRIMP TOOL AND ACCESSORY					ASSEMBLY TOOLS	
BIN*	COLOR	AF8	AFM8	MH860	WA23 (POS)	WA23 (DIE)	INSTALLING	REMOVAL
235 254	RED-ORANGE-GREEN RED-GREEN-YELLOW	TH1A TH1A					DAK12B DAK12B	DRK12B DRK12B
229 248	RED-RED-WHITE RED-YELLOW-GRAY	TH1A TH1A		86-2 86-2			DAK16B DAK16B	DRK16B DRK16B
241 260	RED-YELLOW-BROWN RED-BLUE-BLACK	TH1A TH1A	K1S K1S	86-1S 86-1S			DAK20B DAK20B	DRK20B DRK20B

*The three number suffix on M39029 series contacts is referred to as a "BIN" code. See page 27 for color stripe association.

DMC does not provide connectors, contacts or wiring components. Parts shown here are for reference only. See disclaimer of liability on page 27.

MIL-DTL-28748

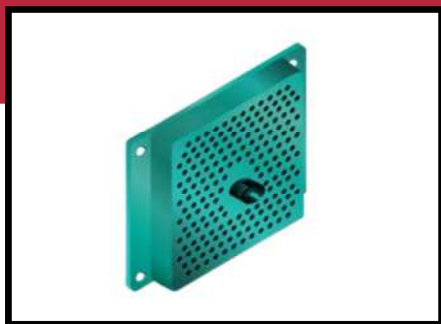

RECTANGULAR RACK AND PANEL

CONNECTOR P/N	DESCRIPTION	QPL SOURCES
M28748/3	PIN CONTACTS SIZE 16 & 20	CONTINENTAL CONNECTOR CO., POSITRONIC INDUSTRIES, WINCHESTER ELECTRONICS, DELPHI CONNECTION SYSTEMS, J-TECH, INC.
M28748/4	SOCKET CONTACTS SIZE 16 & 20	
M28748/9	PIN CONTACTS 16 POLARIZED CENTER SCREW LOCK	
M28748/10	SOCKET CONTACTS 16 POLARIZED CENTER SCREW LOCK	
M28748/13	PIN CONTACTS 22	
M28748/14	SOCKET CONTACTS 22	

CONTACTS	SIZE (AWG)		PIN/SKT.	PART NUMBER* (CURRENT)	PART NUMBER (SUPERSEDED)	WIRE RANGE
	MATING END	WIRE BARREL				
<p>TYPICAL CONTACT CONFIGURATION</p>	16	16	P	M39029/36-278	MS17807-16-16	16-20
	16	16	S	M39029/37-280	MS17808-16-16	16-20
	16	20	P	M39029/36-277	MS17807-16-20	20-24
	16	20	S	M39029/37-279	MS17808-16-20	20-24
	16	16	P	M39029/34-273	MS17803-16-16	16-20
	16	16	S	M39029/35-276	MS17804-16-16	16-20
	16	20	P	M39029/34-272	MS17803-16-20	20-24
	16	20	S	M39029/35-275	MS17804-16-20	20-24
	20	20	P	M39029/34-271	MS17803-20-20	20-24
	20	20	S	M39029/35-274	MS17804-20-20	20-24
	22	22	P	M39029/34-440	M39029/34-22-22	22-26
	22	22	S	M39029/35-441	M39029/35-22-22	22-26

TOOL SELECTION		CRIMP TOOL AND ACCESSORY					ASSEMBLY TOOLS	
BIN*	COLOR	AF8	AFM8	MH860	WA23 (POS)	WA23 (DIE)	INSTALLING	REMOVAL
278	RED-VIOLET-GRAY	TH4					DAK123A	DRK124A
280	RED-GRAY-BLACK	TH4					DAK123A	DRK124A
277	RED-VIOLET-VIOLET	TH4					DAK123A	DRK124A
279	RED-VIOLET-WHITE	TH4					DAK123A	DRK124A
273	RED-VIOLET-ORANGE	TH4		86-146			DAK123A	DRK124A
276	RED-VIOLET-BLUE	TH4		86-146			DAK123A	DRK124A
272	RED-VIOLET-RED	TH4		86-146			DAK123A	DRK124A
275	RED-VIOLET-GREEN	TH4		86-146			DAK123A	DRK124A
271	RED-VIOLET-BROWN	TH4		86-146			DAK123A	DRK124A
274	RED-VIOLET-YELLOW	TH4		86-146			DAK123A	DRK124A
440	YELLOW-YELLOW-BLACK		K280				DAK123-22A	DRK124-22A
441	YELLOW-YELLOW-BROWN		K280				DAK123-22A	DRK124-22A

*The three number suffix on M39029 series contacts is referred to as a "BIN" code. See page 27 for color stripe association.

DMC does not provide connectors, contacts or wiring components. Parts shown here are for reference only. See disclaimer of liability on page 27.



MIL-DTL-28804

RECTANGULAR POLARIZED CENTER JACKSCREW HIGH DENSITY REAR RELEASE CONTACT

CONNECTOR P/N	DESCRIPTION	QPL SOURCES
M28804/1	NON-ENVIRONMENTAL RECEPTACLE (SOCKETS)	DELPHI CONNECTION SYSTEMS
M28804/2	NON-ENVIRONMENTAL PLUG (PINS)	
M28804/3	ENVIRONMENTAL RECEPTACLE (SOCKETS)	
M28804/4	ENVIRONMENTAL PLUG (PINS)	
M28804/5	ENVIRONMENTAL RECEPTACLE (SOCKETS) (POTTING TYPE)	
M28804/6	ENVIRONMENTAL PLUG (PINS) (POTTING TYPE)	

CONTACTS	SIZE (AWG)		PIN/SKT.	PART NUMBER* (CURRENT)	PART NUMBER (SUPERSEDED)	WIRE RANGE
	MATING END	WIRE BARREL				
 <p>TYPICAL CONTACT CONFIGURATION</p>	22	22D	P	M28804/9-1		22-28
	22	22D	S	M28804/10-1		22-28

TOOL SELECTION		CRIMP TOOL AND ACCESSORY					ASSEMBLY TOOLS	
BIN*	COLOR	AF8	AFM8	MH860	WA23 (POS)	WA23 (DIE)	INSTALLING	REMOVAL
--	NONE		K473	86-193			M81969/1-04	M81969/1-04
--	NONE		K473	86-193			M81969/1-04	M81969/1-04

*The three number suffix on M39029 series contacts is referred to as a "BIN" code. See page 27 for color stripe association.

DMC does not provide connectors, contacts or wiring components. Parts shown here are for reference only. See disclaimer of liability on page 27.

MIL-DTL-28840

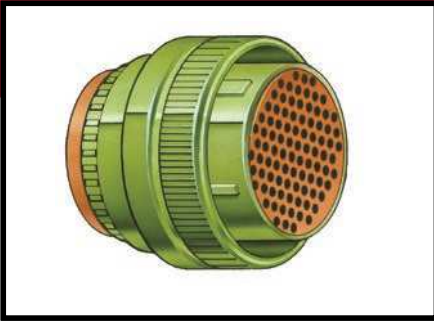

CIRCULAR - THREADED COUPLING FRONT RELEASE CONTACTS HIGH DENSITY - HIGH SHOCK

CONNECTOR P/N	DESCRIPTION	QPL SOURCES
M28840/10	WALL MOUNT RECEPTACLE	GLENAIR
M28840/11	CABLE CONNECTING RECEPTACLE	
M28840/12	BOX MOUNT RECEPTACLE	
M28840/14	JAM NUT MOUNT RECEPTACLE	
M28840/16	STRAIGHT PLUG	
M28840/17	PLUG OPEN WIRE ASSEMBLY	
M28840/18	PLUG OPEN WIRE ASSEMBLY 90° ELBOW	
M28840/19	PLUG OPEN WIRE ASSEMBLY 45° ELBOW	
M28840/20	WALL MOUNT ASSEMBLY STRAIGHT	
M28840/21	CABLE CONVERTING ASSEMBLY STRAIGHT	
M28840/26	PLUG ASSEMBLY STRAIGHT	
M28840/28	PLUG ASSEMBLY 90° ELBOW	
M28840/29	PLUG ASSEMBLY 45° ELBOW	

CONTACTS	SIZE (AWG)		PIN/SKT.	PART NUMBER* (CURRENT)	PART NUMBER (SUPERSEDED)	WIRE RANGE
	MATING END	WIRE BARREL				
	20	20	P	M39029/83-508	M39029/83-20-20	20-24
	20	20	S	M39029/84-509	M39029/84-20-20	20-24
	20	22	P	M39029/83-450	M39029/83-20-22	22-26
	20	22	S	M39029/84-452	M39029/84-20-22	22-26
TYPICAL CONTACT CONFIGURATION	20	28	P	M39029/83-451	M39029/83-20-28	28-32
	20	28	S	M39029/84-453	M39029/84-20-28	28-32

TOOL SELECTION		CRIMP TOOL AND ACCESSORY				ASSEMBLY TOOLS	
BIN*	COLOR	AF8	AFM8	MH860	39-000	INSTALLING	REMOVAL
508 509	GREEN-BLACK-GRAY GREEN-BLACK-WHITE		K534 K534		39-102 39-102	DAK55-22SA (STRAIGHT) or DAK55-22JA (OFFSET)	DRK56-22A DRK56-22A
450 452	YELLOW-GREEN-BLACK YELLOW-GREEN-RED		K534 K534		39-102 39-102	DAK55-22SA (STRAIGHT) or DAK55-22JA (OFFSET)	DRK56-22A DRK56-22A
451 453	YELLOW-GREEN-BROWN YELLOW-GREEN-ORANGE		K534 K534		39-102 39-102	DAK55-22SA (STRAIGHT) or DAK55-22JA (OFFSET)	DRK56-22A DRK56-22A

*The three number suffix on M39029 series contacts is referred to as a "BIN" code. See page 27 for color stripe association.

DMC does not provide connectors, contacts or wiring components. Parts shown here are for reference only. See disclaimer of liability on page 27.



MIL-C-38300

CIRCULAR THREADED OR BAYONET COUPLING FRONT RELEASE CONTACTS

CONNECTOR P/N	DESCRIPTION	QPL SOURCES
MS24264	FLANGE MOUNT RECEPTACLE	NO QPL SOURCES
MS24265	SINGLE HOLE MOUNT RECEPTACLE	
MS24266	STRAIGHT PLUG	

CONTACTS	SIZE (AWG)		PIN/SKT.	PART NUMBER* (CURRENT)	PART NUMBER (SUPERSEDED)	WIRE RANGE
	MATING END	WIRE BARREL				
 TYPICAL CONTACT CONFIGURATION	16 16	16 16	P S	M39029/31-229 M39029/32-248	MS24254-16P MS24255-16S	16-20 16-20
	20 20	20 20	P S	M39029/31-241 M39029/32-260	MS24254-20P MS24255-20S	20-24 20-24

TOOL SELECTION		CRIMP TOOL AND ACCESSORY					ASSEMBLY TOOLS	
BIN*	COLOR	AF8	AFM8	MH860	WA23 (POS)	WA23 (DIE)	INSTALLING	REMOVAL
229 248	RED-RED-WHITE RED-YELLOW-GRAY	TH1A TH1A		86-2 86-2			DAK16B DAK16B	DRK16B DRK16B
241 260	RED-YELLOW-BROWN RED-BLUE-BLACK	TH1A TH1A	K1S K1S	86-1S 86-1S			DAK20B DAK20B	DRK20B DRK20B

*The three number suffix on M39029 series contacts is referred to as a "BIN" code. See page 27 for color stripe association.

MIL-DTL-38999

SERIES 1 (PART 1 OF 2)



SCOOP PROOF – CIRCULAR BAYONET COUPLING REAR RELEASE CONTACTS

CONNECTOR P/N	DESCRIPTION	QPL SOURCES
MS27466	WALL MOUNT FLANGE RECEPTACLE	AMERICAN MICRO, AMPHENOL, AMPHENOL/ SOCAPEX, CORSAIR HI REL, DEUTSCH/TE, ELECTRONIC SEALS, GLASSEAL, GLENAIR, ITT CANNON, PLESSEY, RMS, SAE, SEALTRON, SOURIAU, SPACECRAFT COMPONENTS
MS27467	STRAIGHT PLUG	
MS27468	JAM NUT MOUNT RECEPTACLE	
MS27496	RECEPTACLE	
MS27505	BOX MOUNT FLANGE RECEPTACLE	
MS27656	BACK PANEL WALL MOUNT RECEPTACLE	

CONTACTS	SIZE (AWG)		PIN/SKT.	PART NUMBER* (CURRENT)	PART NUMBER (SUPERSEDED)	WIRE RANGE
	MATING END	WIRE BARREL				
<p>TYPICAL CONTACT CONFIGURATION</p>	12	12	P	M39029/58-365	MS27493-12	12-14
	12	12	S	M39029/56-353	MS27490-12	12-14
	16	16	P	M39029/58-364	MS27493-16	16-20
	16	16	S	M39029/56-352	MS27490-16	16-20
	20	20	P	M39029/58-363	MS27493-20	20-24
	20	20	S	M39029/56-351	MS27490-20	20-24
	22	22	P	M39029/58-362	MS27493-22	22-26
	22	22	S	M39029/56-350	MS27490-22	22-26
	22	22M	P	M39029/58-361	MS27493-22M	24-28
	22	22M	S	M39029/56-349	MS27490-22M	24-28
	22	22D	P	M39029/58-360	MS27493-22D	22-28
	22	22D	S	M39029/56-348	MS27490-22D	22-28
	10	10	P	M39029/58-528	—	10
	10	10	S	M39029/56-527	—	10

TOOL SELECTION		CRIMP TOOL AND ACCESSORY				ASSEMBLY TOOLS	
BIN*	COLOR	AF8	AFM8	MH860	1716P-1	INSTALLING	REMOVAL
365	ORANGE-BLUE-GREEN	TH163				DAK95-12B	DRK95-12B
353	ORANGE-GREEN-ORANGE	TH163				DAK95-12B	DRK95-12B
364	ORANGE-BLUE-YELLOW	TH163		86-3		DAK95-16B	DRK95-16B
352	ORANGE-GREEN-RED	TH163		86-3		DAK95-16B	DRK95-16B
363	ORANGE-BLUE-ORANGE	TH163	K43	86-7		DAK95-20B	DRK95-20B
351	ORANGE-GREEN-BROWN	TH163	K43	86-7		DAK95-20B	DRK95-20B
362	ORANGE-BLUE-RED		K42	86-6		DAK95-22B	DRK95-22B
350	ORANGE-GREEN-BLACK		K40	86-4		DAK95-22B	DRK95-22B
361	ORANGE-BLUE-BROWN		K42	86-6		DAK95-22MB	DRK95-22MB
349	ORANGE-YELLOW-WHITE		K40	86-4		DAK95-22MB	DRK95-22MB
360	ORANGE-BLUE-BLACK		K42	86-6		DAK95-22MB	DRK95-22MB
348	ORANGE-YELLOW-GRAY		K40	86-4		DAK95-22MB	DRK95-22MB
528	GREEN-RED-GRAY				AFFIXED TO HEAD	DAK95-10B	DRK95-10B
527	GREEN-RED-VIOLET				AFFIXED TO HEAD	DAK95-10B	DRK95-10B

*The three number suffix on M39029 series contacts is referred to as a "BIN" code. See page 27 for color stripe association.

Contact M39029/74-423 (Shielded Socket) #12 cavity, solder.
 Contact M39029/75-416 to 422 (Shielded Socket) #12 cavity, see page 88.
 Contact M39029/76-424 to 427 (Shielded Pin) #16 cavity, see page 88.
 Contact M39029/77-428 to 432 (Shielded Socket) #16 cavity, see page 88.
 Contact M39029/78-433 to 425 (Shielded Socket) #16 cavity, see page 88.

Contact M39029/87 is a Thermocouple.
 Contact M39029/88 is a Thermocouple.
 Contact M39029/102 (Coaxial Pin, Size 12) See page 88.
 Contact M39029/103 (Coaxial Socket, Size 12) See page 88.

DMC does not provide connectors, contacts or wiring components. Parts shown here are for reference only. See disclaimer of liability on page 27.

MIL-DTL-38999

SERIES 1 (PART 2 OF 2)



SCOOP PROOF – CIRCULAR BAYONET COUPLING REAR RELEASE CONTACTS

CONTACTS	SIZE (AWG)		PIN/SKT.	PART NUMBER* (CURRENT)	PART NUMBER (SUPERSEDED)	WIRE RANGE
	MATING END	WIRE BARREL				
<p>TYPICAL CONTACT CONFIGURATION</p>	10	10	S	M39029/117-637	--	10
	10	10	S	M39029/117-643	--	10
	10	10	P	M39029/118-649	--	10
	10	10	P	M39029/118-655	--	10
	12	12	S	M39029/117-636	--	12-14
	12	12	S	M39029/117-642	--	12-14
	12	12	P	M39029/118-648	--	12-14
	12	12	P	M39029/118-654	--	12-14
	16	16	S	M39029/117-635	--	16-20
	16	16	S	M39029/117-641	--	16-20
	16	16	P	M39029/118-647	--	16-20
	16	16	P	M39029/118-653	--	16-20
	20	20	S	M39029/117-634	--	20-24
	20	20	S	M39029/117-640	--	20-24
20	20	P	M39029/118-646	--	20-24	
20	20	P	M39029/118-652	--	20-24	
22	22D	S	M39029/117-632	--	22-28	
22	22D	S	M39029/117-638	--	22-28	
22	22D	P	M39029/118-644	--	22-28	
22	22D	P	M39029/118-650	--	22-28	

TOOL SELECTION		CRIMP TOOL AND ACCESSORY				ASSEMBLY TOOLS	
BIN*	COLOR	AF8	AFM8	MH860	1716P-1	INSTALLING	REMOVAL
637	BLUE-ORANGE-VIOLET				AFFIXED TO HEAD	M81969/14-05	M81969/14-05
643	BLUE-YELLOW-ORANGE				AFFIXED TO HEAD	M81969/14-05	M81969/14-05
649	BLUE-YELLOW-WHITE				AFFIXED TO HEAD	M81969/14-05	M81969/14-05
655	BLUE-GREEN-GREEN				AFFIXED TO HEAD	M81969/14-05	M81969/14-05
636	BLUE-ORANGE-BLUE	TH163				DAK95-12B	DRK95-12B
642	BLUE-YELLOW-RED	TH163				DAK95-12B	DRK95-12B
648	BLUE-YELLOW-GRAY	TH163				DAK95-12B	DRK95-12B
654	BLUE-GREEN-YELLOW	TH163				DAK95-12B	DRK95-12B
635	BLUE-ORANGE-GREEN	TH163		86-3		DAK95-16B	DRK95-16B
641	BLUE-YELLOW-BROWN	TH163		86-3		DAK95-16B	DRK95-16B
647	BLUE-YELLOW-VIOLET	TH163		86-3		DAK95-16B	DRK95-16B
653	BLUE-GREEN-ORANGE	TH163		86-3		DAK95-16B	DRK95-16B
634	BLUE-ORANGE-YELLOW	TH163	K43			DAK95-20B	DRK95-20B
640	BLUE-YELLOW-BLACK	TH163	K43			DAK95-20B	DRK95-20B
646	BLUE-YELLOW-BLUE	TH163	K43			DAK95-20B	DRK95-20B
652	BLUE-GREEN-RED	TH163	K43			DAK95-20B	DRK95-20B
632	BLUE-ORANGE-RED		K40	86-4		DAK95-22MB	DRK95-22MB
638	BLUE-ORANGE-GRAY		K40	86-4		DAK95-22MB	DRK95-22MB
644	BLUE-YELLOW-YELLOW		K42	86-6		DAK95-22MB	DRK95-22MB
650	BLUE-GREEN-BLACK		K42	86-6		DAK95-22MB	DRK95-22MB

*The three number suffix on M39029 series contacts is referred to as a "BIN" code. See page 27 for color stripe association.

DMC does not provide connectors, contacts or wiring components. Parts shown here are for reference only. See disclaimer of liability on page 27.

MIL-DTL-38999

SERIES 2



LOW SILHOUETTE – CIRCULAR BAYONET COUPLING REAR RELEASE CONTACTS

CONNECTOR P/N	DESCRIPTION	QPL SOURCES
MS27472	WALL MOUNT FLANGE RECEPTACLE	AERO ELECTRIC, AMERICAN MICRO, AMPHENOL, CONNECTOR INDUSTRIES, CORSAIR, DETORONICS, ELECTRONIC SEALS, GLASSEAL, GLENAIR, HERMETIC SEAL Corporation, HI REL, ITT CANNON, PLESSEY, SEALTRON, SOURIAU, SPI
MS27473	STRAIGHT PLUG	
MS27474	JAM NUT MOUNT RECEPTACLE	
MS27499	BOX MOUNT RECEPTACLE	
MS27508	BOX MOUNT FLANGE RECEPTACLE	
MS27497	BACK PANEL WALL MOUNT RECEPTACLE	
MS27484	RFI PLUG	

CONTACTS	SIZE (AWG)		PIN/SKT.	PART NUMBER* (CURRENT)	PART NUMBER (SUPERSEDED)	WIRE RANGE
	MATING END	WIRE BARREL				
<p>TYPICAL CONTACT CONFIGURATION</p>	12	12	P	M39029/58-365	MS27493-12	12-14
	12	12	S	M39029/57-359	MS27491-12	12-14
	16	16	P	M39029/58-364	MS27493-16	16-20
	16	16	S	M39029/57-358	MS27491-16	16-20
	20	20	P	M39029/58-363	MS27493-10	20-24
	20	20	S	M39029/57-357	MS27491-20	20-24
	22	22	P	M39029/58-362	MS27493-22	22-26
	22	22	S	M39029/57-356	MS27491-22	22-26
	22	22M	P	M39029/58-361	MS27493-22M	24-28
	22	22M	S	M39029/57-355	MS27491-22M	24-28
	22	22D	P	M39029/58-360	MS27493-22D	22-28
	22	22D	S	M39029/57-354	MS27491-22D	22-28

TOOL SELECTION		CRIMP TOOL AND ACCESSORY					ASSEMBLY TOOLS	
BIN*	COLOR	AF8	AFM8	MH860	WA23 (POS)	WA23 (DIE)	INSTALLING	REMOVAL
365	ORANGE-BLUE-GREEN	TH163					DAK95-12B	DRK95-12B
359	ORANGE-GREEN-WHITE	TH163					DAK95-12B	DRK95-12B
364	ORANGE-BLUE-YELLOW	TH163		86-3			DAK95-16B	DRK95-16B
358	ORANGE-GREEN-GRAY	TH163		86-3			DAK95-16B	DRK95-16B
363	ORANGE-BLUE-ORANGE	TH163	K43	86-7			DAK95-20B	DRK95-20B
357	ORANGE-GREEN-VIOLET	TH163	K43	86-7			DAK95-20B	DRK95-20B
362	ORANGE-BLUE-RED		K42	86-6			DAK95-22B	DRK95-22B
356	ORANGE-GREEN-BLUE		K41	86-5			DAK95-22B	DRK95-22B
361	ORANGE-BLUE-BROWN		K42	86-6			DAK95-22MB	DRK95-22MB
355	ORANGE-GREEN-GREEN		K41	86-5			DAK95-22MB	DRK95-22MB
360	ORANGE-BLUE-BLACK		K42	86-6			DAK95-22MB	DRK95-22MB
354	ORANGE-GREEN-YELLOW		K41	86-5			DAK95-22MB	DRK95-22MB

*The three number suffix on M39029 series contacts is referred to as a "BIN" code. See page 27 for color stripe association.

Contact M39029/27-210 (Shielded Socket) #12 cavity, see page 87.

Contact M39029/28-271 (Shielded Pin) #12 cavity, see page 87.

Contact M39029/89 is a Thermocouple.

Contact M39029/102 (Coaxial Pin, Size 12), see page 88.

DMC does not provide connectors, contacts or wiring components. Parts shown here are for reference only. See disclaimer of liability on page 27.

MIL-DTL-38999

SERIES 3 (PART 1 OF 3)



TRI-START COUPLING CIRCULAR REAR RELEASE CONTACTS

CONNECTOR P/N	DESCRIPTION	QPL SOURCES
D38999/20	WALL MOUNT FLANGE RECEPTACLE	AERO ELECTRIC, AMERICAN MICRO, AMPHENOL, AMPHENOL/SOCAPEX, CONESYS EUROPE, CORSAIR, DEUTSCH/TE, ELECTRONIC SEALS, G&H TECH/COOPER, HERMETIC SEAL, HI REL, ITT CANNON, PLESSEY, SEALTRON, SOURIAU, SPACECRAFT, GLENAIR
D38999/24 & /34	JAM NUT MOUNT RECEPTACLE	
D38999/26	STRAIGHT PLUG	
D38999/29 & /31	LAYNARD RELEASE PLUG	
D38999/35	WALL MOUNT RECEPTACLE	
D38999/36	LAYNARD RELEASE PLUG	

CONTACTS	SIZE (AWG)		PIN/SKT.	PART NUMBER* (CURRENT)	PART NUMBER (SUPERSEDED)	WIRE RANGE
	MATING END	WIRE BARREL				
 <p>TYPICAL CONTACT CONFIGURATION</p>	12	12	P	M39029/58-365	MS27493-12	12-14
	12	12	S	M39029/56-353	MS27490-12	12-14
	16	16	P	M39029/58-364	MS27493-16	16-20
	16	16	S	M39029/56-352	MS27490-16	16-20
	20	20	P	M39029/58-363	MS27493-20	20-24
	20	20	S	M39029/56-351	MS27490-20	20-24
	22	22	P	M39029/58-362	MS27493-22	22-26
	22	22	S	M39029/56-350	MS27490-22	22-26
	22	22M	P	M39029/58-361	MS27493-22M	24-28
	22	22M	S	M39029/56-349	MS27490-22M	24-28
	22	22D	P	M39029/58-360	MS27493-22D	22-28
	22	22D	S	M39029/56-348	MS27490-22D	22-28
	10	10	P	M39029/58-528	—	10
	10	10	S	M39029/56-527	—	10

TOOL SELECTION		CRIMP TOOL AND ACCESSORY				ASSEMBLY TOOLS	
BIN*	COLOR	AF8	AFM8	MH860	1716P-1	INSTALLING	REMOVAL
365	ORANGE-BLUE-GREEN	TH163				DAK95-12B	DRK95-12B
353	ORANGE-GREEN-ORANGE	TH163				DAK95-12B	DRK95-12B
364	ORANGE-BLUE-YELLOW	TH163		86-3		DAK95-16B	DRK95-16B
352	ORANGE-GREEN-RED	TH163		86-3		DAK95-16B	DRK95-16B
363	ORANGE-BLUE-ORANGE	TH163	K43	86-7		DAK95-20B	DRK95-20B
351	ORANGE-GREEN-BROWN	TH163	K43	86-7		DAK95-20B	DRK95-20B
362	ORANGE-BLUE-RED		K42	86-6		DAK95-22B	DRK95-22B
350	ORANGE-GREEN-BLACK		K40	86-4		DAK95-22B	DRK95-22B
361	ORANGE-BLUE-BROWN		K42	86-6		DAK95-22MB	DRK95-22MB
349	ORANGE-YELLOW-WHITE		K40	86-4		DAK95-22MB	DRK95-22MB
360	ORANGE-BLUE-BLACK		K42	86-6		DAK95-22MB	DRK95-22MB
348	ORANGE-YELLOW-GRAY		K40	86-4		DAK95-22MB	DRK95-22MB
528	GREEN-RED-GRAY				AFFIXED TO HEAD	DAK95-10B	DRK95-10B
527	GREEN-RED-VIOLET				AFFIXED TO HEAD	DAK95-10B	DRK95-10B

* The three number suffix on M39029 series contacts is referred to as a "BIN" code. See page 27 for color stripe association.

Contact M39029/74-423 (Shielded Socket) #12 cavity, solder.
 Contact M39029/75-416 to 432 (Shielded Socket) #12 cavity, see page 88.
 Contact M39029/76-424 to 427 (Shielded Pin) #16 cavity, see page 88.
 Contact M39029/77-428 to 431 (Shielded Socket) #16 cavity, see page 88.
 Contact M39029/78-432 to 425 (Shielded Socket) #16 cavity, see page 88.
 Contact M39029/87 and/88 are Thermocouples.

Contact M39029/90, 91, 113 and 114, see MIL-STD-1760 on page 45.
 Contact M39029/102 (Coaxial Pin) Size 12. See page 88.
 Contact M39029/103 (Coaxial Socket) Size 12. See page 88.

DMC does not provide connectors, contacts or wiring components. Parts shown here are for reference only. See disclaimer of liability on page 27.

MIL-DTL-38999

SERIES 3 (PART 2 OF 3)



TRI-START COUPLING CIRCULAR REAR RELEASE CONTACTS

CONTACTS	SIZE (AWG)		PIN/SKT.	PART NUMBER* (CURRENT)	PART NUMBER (SUPERSEDED)	WIRE RANGE
	MATING END	WIRE BARREL				
 <p>TYPICAL CONTACT CONFIGURATION</p>	10	10	S	M39029/117-637	--	10
	10	10	S	M39029/117-643	--	10
	10	10	P	M39029/118-649	--	10
	10	10	P	M39029/118-655	--	10
	12	12	S	M39029/117-636	--	12-14
	12	12	S	M39029/117-642	--	12-14
	12	12	P	M39029/118-648	--	12-14
	12	12	P	M39029/118-654	--	12-14
	16	16	S	M39029/117-635	--	16-20
	16	16	S	M39029/117-641	--	16-20
	16	16	P	M39029/118-647	--	16-20
	16	16	P	M39029/118-653	--	16-20
	20	20	S	M39029/117-634	--	20-24
	20	20	S	M39029/117-640	--	20-24
20	20	P	M39029/118-646	--	20-24	
20	20	P	M39029/118-652	--	20-24	
22	22D	S	M39029/117-632	--	22-28	
22	22D	S	M39029/117-638	--	22-28	
22	22D	P	M39029/118-644	--	22-28	
22	22D	P	M39029/118-650	--	22-28	

TOOL SELECTION		CRIMP TOOL AND ACCESSORY				ASSEMBLY TOOLS	
BIN*	COLOR	AF8	AFM8	MH860	1716P-1	INSTALLING	REMOVAL
637	BLUE-ORANGE-VIOLET				AFFIXED TO HEAD	DAK95-10B	DRK95-10B
643	BLUE-YELLOW-ORANGE				AFFIXED TO HEAD	DAK95-10B	DRK95-10B
649	BLUE-YELLOW-WHITE				AFFIXED TO HEAD	DAK95-10B	DRK95-10B
655	BLUE-GREEN-GREEN				AFFIXED TO HEAD	DAK95-10B	DRK95-10B
636	BLUE-ORANGE-BLUE	TH163				DAK95-12B	DRK95-12B
642	BLUE-YELLOW-RED	TH163				DAK95-12B	DRK95-12B
648	BLUE-YELLOW-GRAY	TH163				DAK95-12B	DRK95-12B
654	BLUE-GREEN-YELLOW	TH163				DAK95-12B	DRK95-12B
635	BLUE-ORANGE-GREEN	TH163		86-3		DAK95-16B	DRK95-16B
641	BLUE-YELLOW-BROWN	TH163		86-3		DAK95-16B	DRK95-16B
647	BLUE-YELLOW-VIOLET	TH163		86-3		DAK95-16B	DRK95-16B
653	BLUE-GREEN-ORANGE	TH163		86-3		DAK95-16B	DRK95-16B
634	BLUE-ORANGE-YELLOW	TH163	K43			DAK95-20B	DRK95-20B
640	BLUE-YELLOW-BLACK	TH163	K43			DAK95-20B	DRK95-20B
646	BLUE-YELLOW-BLUE	TH163	K43			DAK95-20B	DRK95-20B
652	BLUE-GREEN-RED	TH163	K43			DAK95-20B	DRK95-20B
632	BLUE-ORANGE-RED		K40	86-4		DAK95-22MB	DRK95-22MB
638	BLUE-ORANGE-GRAY		K40	86-4		DAK95-22MB	DRK95-22MB
644	BLUE-YELLOW-YELLOW		K42	86-6		DAK95-22MB	DRK95-22MB
650	BLUE-GREEN-BLACK		K42	86-6		DAK95-22MB	DRK95-22MB

*The three number suffix on M39029 series contacts is referred to as a "BIN" code. See page 27 for color stripe association.

DMC does not provide connectors, contacts or wiring components. Parts shown here are for reference only. See disclaimer of liability on page 27.

MIL-DTL-38999

SERIES 3 (PART 3 OF 3)



TRI-START COUPLING CIRCULAR REAR RELEASE CONTACTS

CONTACTS	SIZE (AWG)		PIN/SKT.	PART NUMBER* (CURRENT)	PART NUMBER (SUPERSEDED)	WIRE RANGE
	MATING END	WIRE BARREL				
 TYPICAL CONTACT CONFIGURATION	10	10	S	M39029/121-668	--	10
	10	10	P	M39029/122-675	--	10
	12	12	S	M39029/121-667	--	12-14
	12	12	P	M39029/122-674	--	12-14
	16	16	S	M39029/121-666	--	16-20
	16	16	P	M39029/122-673	--	16-20
	20	20	S	M39029/121-665	--	20-24
	20	20	P	M39029/122-672	--	20-24
	22	22D	S	M39029/121-664	--	22-28
	22	22D	P	M39029/122-671	--	22-28
	23	26	S	M39029/121-662	--	23-26
	23	26	P	M39029/122-669	--	23-26
23	22	S	M39029/121-663	--	22-26	
23	22	P	M39029/122-670	--	22-26	

TOOL SELECTION		CRIMP TOOL AND ACCESSORY				ASSEMBLY TOOLS	
BIN*	COLOR	AF8	AFM8	MH860	1716P-1	INSTALLING	REMOVAL
668 675	BLUE-BLUE-GRAY BLUE-VIOLET-GREEN				AFFIXED TO HEAD AFFIXED TO HEAD	DAK95-10B DAK95-10B	DRK95-10B DRK95-10B
667 674	BLUE-BLUE-VIOLET BLUE-VIOLET-YELLOW	TH163 TH163				DAK95-12B DAK95-12B	DRK95-12B DRK95-12B
666 673	BLUE-BLUE-BLUE BLUE-VIOLET-ORANGE	TH163 TH163		86-3 86-3		DAK95-16B DAK95-16B	DRK95-16B DRK95-16B
665 672	BLUE-BLUE-GREEN BLUE-VIOLET-RED	TH163 TH163	K43 K43			DAK95-20B DAK95-20B	DRK95-20B DRK95-20B
664 671	BLUE-BLUE-YELLOW BLUE-VIOLET-BROWN		K40 K40	86-4 86-4		DAK95-22MB DAK95-22MB	DRK95-22MB DRK95-22MB
662 669	BLUE-BLUE-RED BLUE-BLUE-WHITE		K339 K339			M81969/1-05 M81969/1-05	M81969/1-05 M81969/1-05
663 670	BLUE-BLUE-ORANGE BLUE-VIOLET-BLACK		K339 K338			M81969/1-05 M81969/1-05	M81969/1-05 M81969/1-05

*The three number suffix on M39029 series contacts is referred to as a "BIN" code. See page 27 for color stripe association.

DMC does not provide connectors, contacts or wiring components. Parts shown here are for reference only. See disclaimer of liability on page 27.

MIL-STD-1760

(MIL-DTL-38999 - SERIES III VARIATION)



MIL-STD 1760 provides a common, cross platform, mechanical, electrical, and digital interface between weapons/external equipment stores and aircraft. The standard MIL-STD-1760 connector is used to transfer guidance information to weapons. The standard connector for MIL-STD-1760 is D38999 Series III (Reference MIL-DTL-83538) Insert Arrangement #25-20. Lanyard Release Plug (/31), and Jam Nut or Flange Mount Receptacles (Also Rail Launch Configuration is available).

POWER CONTACTS

CONTACT PART NUMBER	TYPE	SIZE	CRIMP TOOL	POSITIONER	INSERTION TOOL*	REMOVAL TOOL*
M39029/58-363	P	20	AFM8	K43	DAK95-20B	DRK95-20B
M39029/56-351	S	20	AFM8	K43	DAK95-20B	DRK95-20B
M39029/58-364	P	16	AF8	TH163	DAK95-16B	DRK95-16B
M39029/56-352	S	16	AF8	TH163	DAK95-16B	DRK95-16B
M39029/58-528	P	10	1716P-1	N/A (Included)	DAK95-10B	DRK95-10B
M39029/56-527	S	10	1716P-1	N/A (Included)	DAK95-10B	DRK95-10B

COAXIAL CONTACTS

CONTACT PART NUMBER	TYPE	SIZE	INNER CRIMP TOOL & POSITIONER		OUTER CRIMP TOOL & POSITIONER		INSERTION TOOL*	REMOVAL TOOL*
M39029/28-211	P	12	AFM8	K323	GS200-1	G2P330	DAK264-12	DRK264-12
M39029/75-416	S	12	AFM8	K323	GS200-1	G2P330	DAK264-12	DRK264-12
M39029/28-409	P	12	AFM8	K323	GS200-1	G2P330	DAK264-12	DRK264-12
M39029/75-417	S	12	AFM8	K323	GS200-1	G2P330	DAK264-12	DRK264-12

* Insertion and Removal of Contacts in MIL-STD-1760 Applications require straight tools due to the restricted access of Lanyard Release Connectors. DAK264-XX Tweezer Type Tools have the same Tip configuration as the corresponding M81969/8-XXX Tools assigned to normal Contact Insertion and Removal operations in D38999, Series III Connectors.

DATA BUS (CONCENTRIC TWINAX) CONTACTS

CONTACT PART NUMBER	TYPE	SIZE	INNER CRIMP TOOL & POSITIONER		INTERMEDIATE CRIMP TOOL & DIE		OUTER CRIMP TOOL & DIE	
M39029/90-529	P	8	AFM8	K709	HX4	Y631 Cir/Indent	Y631 Hex Cavity	--
M39029/91-530	S	8	AFM8	K709	HX4	Y631 Cir/Indent	Y631 Hex Cavity	--
M39029/90-529 Alternate Pre-Assembled	P	8	MH860	86-19	--	--	Y631 Hex Cavity	Y207P Hex Cavity
M39029/91-530 Alternate Pre-Assembled	S	8	MH860	86-19	--	--	Y631 Hex Cavity	Y207P Hex Cavity
M39029/113-625	P	8	AFM8	K709	HX4	Y631 Cir/Indent	Y631 Hex Cavity	--
M39029/114-628	S	8	AFM8	K709	HX4	Y631 Cir/Indent	Y631 Hex Cavity	--

All Size 8 Data Bus Contacts can be inserted with the DAK264-8 and Removed with DRK264-8 Straight Metal Tools (Tweezer Type).

Tool Kits are available for complete MIL-STD-1760 Wiring Support. Consult DMC for Details.

Lanyard Repair Tools and Components are available from DMC. Contact Customer Service for details.

DMC does not provide connectors, contacts or wiring components. Parts shown here are for reference only. See disclaimer of liability on page 27.

MIL-DTL-38999

SERIES 4 (PART 1 OF 2)

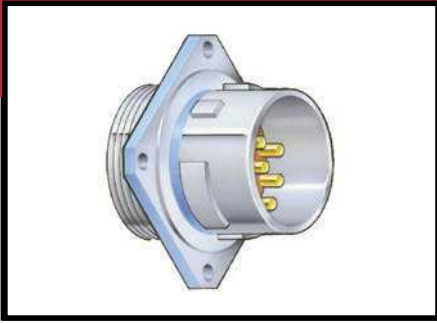

BREECH LOCK COUPLING CIRCULAR REAR RELEASE CONTACTS

CONNECTOR P/N	DESCRIPTION	QPL SOURCES
D38999/40	WALL MOUNT FLANGE RECEPTACLE	CORSAIR, G&H TECH/COOPER, AMPHENOL, AMPHENOL/SOCAPEX, AERO ELECTRIC, DEUTSCH/TE, ELECTRONIC SEALS, ITT CANNON, PLESSEY, AB CONNECTORS, HI REL, SEALTRON, HERMETIC SEAL, CONESYS EUROPE, AMERICAN MICRO, SPACECRAFT, SOURAIU
D38999/42	BOX MOUNT FLANGE RECEPTACLE	
D38999/44	JAM NUT MOUNT RECEPTACLE	
D38999/46	STRAIGHT PLUG	
D38999/47	STRAIGHT PLUG	
D38999/49	CABLE MOUNT RECEPTACLE	

CONTACTS	SIZE (AWG)		PIN/SKT.	PART NUMBER* (CURRENT)	PART NUMBER (SUPERSEDED)	WIRE RANGE
	MATING END	WIRE BARREL				
<p>TYPICAL CONTACT CONFIGURATION</p>	12	12	P	M39029/58-365	MS27493-12	12-14
	12	12	S	M39029/56-353	MS27490-12	12-14
	16	16	P	M39029/58-364	MS27493-16	16-20
	16	16	S	M39029/56-352	MS27490-16	16-20
	20	20	P	M39029/58-363	MS27493-20	20-24
	20	20	S	M39029/56-351	MS27490-20	20-24
	22	22	P	M39029/58-362	MS27493-22	22-26
	22	22	S	M39029/56-350	MS27490-22	22-26
	22	22M	P	M39029/58-361	MS27493-22M	24-28
	22	22M	S	M39029/56-349	MS27490-22M	24-28
	22	22D	P	M39029/58-360	MS27493-22D	22-28
	22	22D	S	M39029/56-348	MS27490-22D	22-28

TOOL SELECTION		CRIMP TOOL AND ACCESSORY				ASSEMBLY TOOLS	
BIN*	COLOR	AF8	AFM8	MH860	1716P-1	INSTALLING	REMOVAL
365 353	ORANGE-BLUE-GREEN ORANGE-GREEN-ORANGE	TH163 TH163				DAK95-12B DAK95-12B	DRK95-12B DRK95-12B
364 352	ORANGE-BLUE-YELLOW ORANGE-GREEN-RED	TH163 TH163		86-3 86-3		DAK95-16B DAK95-16B	DRK95-16B DRK95-16B
363 351	ORANGE-BLUE-ORANGE ORANGE-GREEN-BROWN	TH163 TH163	K43 K43	86-7 86-7		DAK95-20B DAK95-20B	DRK95-20B DRK95-20B
362 350	ORANGE-BLUE-RED ORANGE-GREEN-BLACK		K42 K40	86-6 86-4		DAK95-22B DAK95-22B	DRK95-22B DRK95-22B
361 349	ORANGE-BLUE-BROWN ORANGE-YELLOW-WHITE		K42 K40	86-6 86-4		DAK95-22MB DAK95-22MB	DRK95-22MB DRK95-22MB
360 348	ORANGE-BLUE-BLACK ORANGE-YELLOW-GRAY		K42 K40	86-6 86-4		DAK95-22MB DAK95-22MB	DRK95-22MB DRK95-22MB

*The three number suffix on M39029 series contacts is referred to as a "BIN" code. See page 27 for color stripe association.

Contact M39029/74-423 (Shielded Socket) #12 cavity, solder.
 Contact M39029/75-416 to -432 (Shielded Socket) #12 cavity, see page 88.
 Contact M39029/76-424 to -427 (Shielded Pin) #16 cavity, see page 88.
 Contact M39029/77-428 to -431 (Shielded Socket) #16 cavity, see page 88.
 Contact M39029/78-432 to -425 (Shielded Socket) #16 cavity, see page 88.
 Contact M39029/87 and /88 are Thermocouples.

Contact M39029/90, /91, /113 and /114, see MIL-STD-1760 on page 46.
 Contact M39029/102 (Coaxial Pin) Size 12. See page 88.
 Contact M39029/103 (Coaxial Socket) Size 12. See page 88.

DMC does not provide connectors, contacts or wiring components. Parts shown here are for reference only. See disclaimer of liability on page 27.

MIL-DTL-38999

SERIES 4 (PART 2 OF 2)

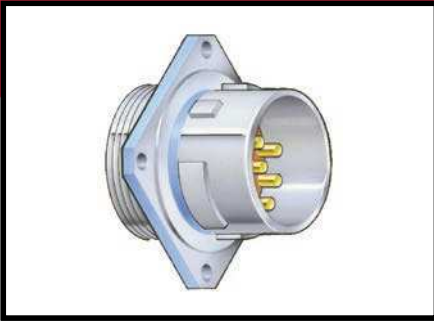

BREECH LOCK COUPLING CIRCULAR REAR RELEASE CONTACTS

CONTACTS	SIZE (AWG)		PIN/SKT.	PART NUMBER* (CURRENT)	PART NUMBER (SUPERSEDED)	WIRE RANGE
	MATING END	WIRE BARREL				
<p>TYPICAL CONTACT CONFIGURATION</p>	10	10	S	M39029/117-637	--	10
	10	10	S	M39029/117-643	--	10
	10	10	P	M39029/118-649	--	10
	10	10	P	M39029/118-655	--	10
	12	12	S	M39029/117-636	--	12-14
	12	12	S	M39029/117-642	--	12-14
	12	12	P	M39029/118-648	--	12-14
	12	12	P	M39029/118-654	--	12-14
	16	16	S	M39029/117-635	--	16-20
	16	16	S	M39029/117-641	--	16-20
	16	16	P	M39029/118-647	--	16-20
	16	16	P	M39029/118-653	--	16-20
	20	20	S	M39029/117-634	--	20-24
	20	20	S	M39029/117-640	--	20-24
	20	20	P	M39029/118-646	--	20-24
	20	20	P	M39029/118-652	--	20-24
22	22D	S	M39029/117-632	--	22-28	
22	22D	S	M39029/117-638	--	22-28	
22	22D	P	M39029/118-644	--	22-28	
22	22D	P	M39029/118-650	--	22-28	

TOOL SELECTION		CRIMP TOOL AND ACCESSORY				ASSEMBLY TOOLS	
BIN*	COLOR	AF8	AFM8	MH860	1716P-1	INSTALLING	REMOVAL
637	BLUE-ORANGE-VIOLET				AFFIXED TO HEAD	M81969/14-05	M81969/14-05
643	BLUE-YELLOW-ORANGE				AFFIXED TO HEAD	M81969/14-05	M81969/14-05
649	BLUE-YELLOW-WHITE				AFFIXED TO HEAD	M81969/14-05	M81969/14-05
655	BLUE-GREEN-GREEN				AFFIXED TO HEAD	M81969/14-05	M81969/14-05
636	BLUE-ORANGE-BLUE	TH163				DAK95-12B	DRK95-12B
642	BLUE-YELLOW-RED	TH163				DAK95-12B	DRK95-12B
648	BLUE-YELLOW-GRAY	TH163				DAK95-12B	DRK95-12B
654	BLUE-GREEN-YELLOW	TH163				DAK95-12B	DRK95-12B
635	BLUE-ORANGE-GREEN	TH163		86-3		DAK95-16B	DRK95-16B
641	BLUE-YELLOW-BROWN	TH163		86-3		DAK95-16B	DRK95-16B
647	BLUE-YELLOW-VIOLET	TH163		86-3		DAK95-16B	DRK95-16B
653	BLUE-GREEN-ORANGE	TH163		86-3		DAK95-16B	DRK95-16B
634	BLUE-ORANGE-YELLOW	TH163	K43			DAK95-20B	DRK95-20B
640	BLUE-YELLOW-BLACK	TH163	K43			DAK95-20B	DRK95-20B
646	BLUE-YELLOW-BLUE	TH163	K43			DAK95-20B	DRK95-20B
652	BLUE-GREEN-RED	TH163	K43			DAK95-20B	DRK95-20B
632	BLUE-ORANGE-RED		K40	86-4		DAK95-22MB	DRK95-22MB
638	BLUE-ORANGE-GRAY		K40	86-4		DAK95-22MB	DRK95-22MB
644	BLUE-YELLOW-YELLOW		K42	86-6		DAK95-22MB	DRK95-22MB
650	BLUE-GREEN-BLACK		K42	86-6		DAK95-22MB	DRK95-22MB

*The three number suffix on M39029 series contacts is referred to as a "BIN" code. See page 27 for color stripe association.

DMC does not provide connectors, contacts or wiring components. Parts shown here are for reference only. See disclaimer of liability on page 27.

AS50151 (FORMERLY MIL-C-5015) SERIES 3400



CIRCULAR THREADED COUPLING FRONT RELEASE CONTACTS

CONNECTOR P/N	DESCRIPTION	QPL SOURCES
MS3400	WALL MOUNT RECEPTACLE	AERO-ELECTRIC CONNECTORS CORSAIR ELECTRICAL J-TECH, INC. ELECSYS, INC.
MS3401	CABLE CONNECTING RECEPTACLE	
MS3402	BOX MOUNT RECEPTACLE	
MS3404	JAM NUT MOUNT RECEPTACLE	
MS3406	STRAIGHT PLUG	
MS3408	PLUG 90°	
MS3409	PLUG 45°	
MS3412	WALL MOUNT RECEPTACLE (AN TYPE)	

CONTACTS	SIZE (AWG)		PIN/SKT.	PART NUMBER* (CURRENT)	PART NUMBER (SUPERSEDED)	WIRE RANGE
	MATING END	WIRE BARREL				
 TYPICAL CONTACT CONFIGURATION	0	0	P	M39029/44-293	MS90453-0-0	0-2*
	0	0	S	M39029/45-300	MS90454-0-0	0-2*
	4	4	P	M39029/44-292	MS90453-4-0	4-6*
	4	4	S	M39029/45-299	MS90454-4-0	4-6*
	8	8	P	M39029/44-291	MS90453-8-0	8-10*
	8	8	S	M39029/45-298	MS90454-8-0	8-10*
	12	12	P	M39029/44-290	MS90453-12-12	12-14
	12	12	S	M39029/45-297	MS90454-12-12	12-14
	12	16	P	M39029/44-289	MS90453-12-16	16-20
	12	16	S	M39029/45-296	MS90454-12-16	16-20
	16	16	P	M39029/44-288	MS90453-16-16	16-20
	16	16	S	M39029/45-295	MS90454-16-16	16-20
	16	22	P	M39029/44-287	MS90453-16-22	22-26
	16	22	S	M39029/45-294	MS90454-16-22	22-26

TOOL SELECTION		CRIMP TOOL AND ACCESSORY					ASSEMBLY TOOLS	
BIN*	COLOR	AF8	AFM8	MH860	WA23 (POS)	WA23 (DIE)	INSTALLING	REMOVAL
293 300	RED-WHITE-ORANGE ORANGE-BLACK-BLACK				WA23-5 WA23-5	WA23-13 WA23-13	DAK55-0B DAK55-0B	DRK56-0B DRK56-0B
292 299	RED-WHITE-RED RED-WHITE-WHITE				WA23-4 WA23-4	WA23-11 WA23-11	DAK55-4B DAK55-4B	DRK56-4B DRK56-4B
291 298	RED-WHITE-BROWN RED-WHITE-GRAY				WA23-2 WA23-2	WA23-9 WA23-9	DAK55-8B DAK55-8B	DRK56-8B DRK56-8B
290 297	RED-WHITE-BLACK RED-WHITE-VIOLET	TH1A TH1A					DAK55-12A DAK55-12A	DRK56-12A DRK56-12A
289 296	RED-GRAY-WHITE RED-WHITE-BLUE	TH1A TH1A					DAK55-12A DAK55-12A	DRK56-12A DRK56-12A
288 295	RED-GRAY-GRAY RED-WHITE-GREEN	TH1A TH1A		86-2 86-2			DAK55-16A DAK55-16A	DRK56-16A DRK56-16A
287 294	RED-GRAY-VIOLET RED-WHITE-YELLOW	TH1A TH1A		86-2 86-2			DAK55-16A DAK55-16A	DRK56-16A DRK56-16A

*The three number suffix on M39029 series contacts is referred to as a "BIN" code. See page 27 for color stripe association.

DMC does not provide connectors, contacts or wiring components. Parts shown here are for reference only. See disclaimer of liability on page 27.

AS50151 (FORMERLY MIL-C-5015) SERIES 3450

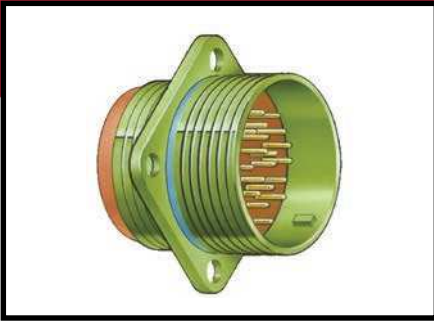

CIRCULAR THREADED COUPLING REAR RELEASE CONTACTS

CONNECTOR P/N	DESCRIPTION	QPL SOURCES
MS3450	WALL MOUNT RECEPTACLE	AERO-ELECTRIC CONNECTORS ITT CANNON J-TECH, INC. AMPHENOL AEORSPACE ELECSYS, INC. CORSAIR ELECTRICAL
MS3451	CABLE CONNECTING RECEPTACLE	
MS3452	BOX MOUNT RECEPTACLE	
MS3454	JAM NUT MOUNT RECEPTACLE	
MS3456	STRAIGHT PLUG	
MS3459	SELF-LOCK COUPLING PLUG	

CONTACTS	SIZE (AWG)		PIN/SKT.	PART NUMBER* (CURRENT)	PART NUMBER (SUPERSEDED)	WIRE RANGE
	MATING END	WIRE BARREL				
 TYPICAL CONTACT CONFIGURATION	12	12	P	M39029/29-213 —	M39029/29-12-12 or MS3162-12-12	12-14
	12	12	S	M39029/30-219 —	M39029/30-12-12 or MS3163-12-12	12-14
	16	16	P	M39029/29-212 —	M39029/29-16-16 or MS3162-16-16	16-20
	16	16	S	M39029/30-218 —	M39029/30-16-16 or MS3163-16-16	16-20
	8	8	P	M39029/29-214	M39029/29-8-8	8
	8	8	S	M39029/30-220	M39029/30-8-8	8
	4	4	P	M39029/29-215	M39029/29-4-4	4
	4	4	S	M39029/30-221	M39029/30-4-4	4
0	0	P	M39029/29-216	M39029/29-0-0	0	
0	0	S	M39029/30-222	M39029/30-0-0	0	

TOOL SELECTION		CRIMP TOOL AND ACCESSORY					ASSEMBLY TOOLS	
BIN*	COLOR	AF8	AFM8	MH860	WA23 (POS)	WA23 (DIE)	INSTALLING	REMOVAL
213	RED-BROWN-ORANGE	TH1A					DAK83-12B	DRK83-12B
219	RED-BROWN-WHITE	TH1A					DAK83-12B	DRK83-12B
212 —	RED-BROWN-RED	TH1A		86-2			DAK83-16B	DRK83-16B
218 —	RED-BROWN-GRAY	TH1A		86-2			DAK83-16B	DRK83-16B
214 220	RED-BROWN-YELLOW RED-RED-BLACK				WA23-9 WA23-9	WA23-2 WA23-2	BY HAND BY HAND	DRK250-8 OR M81969/14-06 DRK250-8 OR M81969/14-06
215 221	RED-BROWN-GREEN RED-RED-BROWN				WA23-11 WA23-11	WA23-4 WA23-4	BY HAND BY HAND	DRK250-4 OR M81969/14-07 DRK250-4 OR M81969/14-07
216 222	RED-BROWN-BLUE RED-RED-RED				WA23-13 WA23-13	WA23-5 WA23-5	BY HAND BY HAND	DRK250-0 OR M81969/14-08 DRK250-0 OR M81969/14-08

*The three number suffix on M39029 series contacts is referred to as a "BIN" code. See page 27 for color stripe association. Contacts M39029/85 and /86 are Thermocouples.

DMC does not provide connectors, contacts or wiring components. Parts shown here are for reference only. See disclaimer of liability on page 27.

SAE AS81511 SERIES 1



SCOOP PROOF** CIRCULAR BAYONET COUPLING FRONT RELEASE CONTACTS

CONNECTOR P/N	DESCRIPTION	QPL SOURCES
M81511/21 & /35	FLANGE MOUNT RECEPTACLE	NO QPL SOURCE
M81511/23 & /36	JAM NUT RECEPTACLE	
M81511/25 & /37	CABLE CONNECTING RECEPTACLE	
M81511/26 & /38	STRAIGHT PLUG	

CONTACTS	SIZE (AWG)		PIN/SKT.	PART NUMBER* (CURRENT)	PART NUMBER (SUPERSEDED)	WIRE RANGE
	MATING END	WIRE BARREL				
<p>TYPICAL CONTACT CONFIGURATION</p>	12	12	P	M39029/47-339	MS90461B12-12	12-14
	12	12	S	M39029/33-270	MS3343B12-12	12-14
	16	16	P	M39029/47-337	MS90461B16-16	16-20
	16	16	S	M39029/33-268	MS3343B16-16	16-20
	20	20	P	M39029/47-316	MS90461B20-20	20-24
	20	20	S	M39029/33-266	MS3343B20-20	20-24
	23	22	P	M39029/47-314	MS90461B23-22	22-26
	23	22	S	M39029/33-264	MS3343B23-22	22-26
	23	28	P	M39029/47-312	MS90461B23-28	28-32
	23	28	S	M39029/33-262	MS3343B23-28	28-32

TOOL SELECTION		CRIMP TOOL AND ACCESSORY					ASSEMBLY TOOLS	
BIN*	COLOR	AF8	AFM8	MH860	WA23 (POS)	WA23 (DIE)	INSTALLING	REMOVAL
339	ORANGE-ORANGE-WHITE	TH199S					DAK126-12A	DRK125-12A
270	RED-VIOLET-BLACK	TH199S					DAK126-12A	DRK129-12A
337	ORANGE-ORANGE-VIOLET	TH199S		86-12S			DAK126-16A	DRK125-16A
268	RED-BLUE-GRAY	TH199S		86-12S			DAK126-16A	DRK129-16A
316	ORANGE-BROWN-BLUE	TH199S		86-11S			DAK126-20A	DRK125-20A
266	RED-BLUE-BLUE	TH199S		86-11S			DAK126-20A	DRK129-20A
314	ORANGE-BROWN-YELLOW		K60S				DAK126-23A	DRK125-23A
264	RED-BLUE-YELLOW		K60S				DAK126-23A	DRK129-23A
312	ORANGE-BROWN-RED		K60S				DAK126-23A	DRK125-23A
262	RED-BLUE-RED		K60S				DAK126-23A	DRK129-23A

*The three number suffix on M39029 series contacts is referred to as a "BIN" code. See page 27 for color stripe association.

**Scoop proof when pins are installed in the receptacle, but not when pins are installed in the plug.

SAE AS81511 SERIES 2



50% SCOOP PROOF
CIRCULAR BAYONET COUPLING
FRONT RELEASE CONTACTS**

CONNECTOR P/N	DESCRIPTION	QPL SOURCES
M81511/1 & /31	FLANGE MOUNT RECEPTACLE	NO QPL SOURCE
M81511/3 & /32	JAM NUT MOUNT RECEPTACLE	
M81511/5 & /33	CABLE CONNECTING RECEPTACLE	
M81511/6 & /34	STRAIGHT PLUG	

CONTACTS	SIZE (AWG)		PIN/SKT.	PART NUMBER* (CURRENT)	PART NUMBER (SUPERSEDED)	WIRE RANGE
	MATING END	WIRE BARREL				
<p>TYPICAL CONTACT CONFIGURATION</p>	12	12	P	M39029/47-339	MS90461A12-12	12-14
	12	12	S	M39029/46-310	MS90460B12-12	12-14
	16	16	P	M39029/47-337	MS90461B16-16	16-20
	16	16	S	M39029/46-308	MS90460B16-16	16-20
	20	20	P	M39029/47-316	MS90461B20-20	20-24
	20	20	S	M39029/46-306	MS90460B20-20	20-24
	23	22	P	M39029/47-314	MS90461B23-22	22-26
	23	22	S	M39029/46-304	MS90460B23-22	22-26
	23	28	P	M39029/47-312	MS90461B23-28	28-32
	23	28	S	M39029/46-302	MS90460B23-28	28-32

TOOL SELECTION		CRIMP TOOL AND ACCESSORY					ASSEMBLY TOOLS	
BIN*	COLOR	AF8	AFM8	MH860	WA23 (POS)	WA23 (DIE)	INSTALLING	REMOVAL
339	ORANGE-ORANGE-WHITE	TH199S					DAK126-12A	DRK125-12A
310	ORANGE-BROWN-BLACK	TH199S					DAK126-12A	DRK129-12A
337	ORANGE-ORANGE-VIOLET	TH199S		86-12S			DAK126-16A	DRK125-16A
308	ORANGE-BLACK-GRAY	TH199S		86-12S			DAK126-16A	DRK129-16A
316	ORANGE-BROWN-BLUE	TH199S		86-11S			DAK126-20A	DRK125-20A
306	ORANGE-BLACK-BLUE	TH199S		86-11S			DAK126-20A	DRK129-20A
314	ORANGE-BROWN-YELLOW		K60S				DAK126-23A	DRK125-23A
304	ORANGE-BLACK-YELLOW		K60S				DAK126-23A	DRK129-23A
312	ORANGE-BROWN-RED		K60S				DAK126-23A	DRK125-23A
302	ORANGE-BLACK-RED		K60S				DAK126-23A	DRK129-23A

*The three number suffix on M39029 series contacts is referred to as a "BIN" code. See page 27 for color stripe association.

**Scoop proof when pins are installed in the receptacle, but not when pins are installed in the plug.

SAE AS81511

SERIES 3



SCOOP PROOF** CIRCULAR BAYONET COUPLING REAR RELEASE CONTACTS

CONNECTOR P/N	DESCRIPTION	QPL SOURCES
M81511/41	FLANGE MOUNT RECEPTACLE	TE/DEUTSCH
M81511/45	CABLE CONNECTING RECEPTACLE	
M81511/46	STRAIGHT PLUG	
M81511/49	JAM NUT MOUNT RECEPTACLE	

CONTACTS	SIZE (AWG)		PIN/SKT.	PART NUMBER* (CURRENT)	PART NUMBER (SUPERSEDED)	WIRE RANGE
	MATING END	WIRE BARREL				
<p>TYPICAL CONTACT CONFIGURATION</p>	12	12	P	M39029/18-180	M39029/18-12-12	12-14
	12	12	S	M39029/17-175	M39029/17-12-12	12-14
	16	16	P	M39029/18-179	M39029/18-16-16	16-20
	16	16	S	M39029/17-174	M39029/17-16-16	16-20
	16	16	S	M39029/22-193	M39029/22-16-16	16-20
	20	20	P	M39029/18-178	M39029/18-20-20	16-20
	20	20	S	M39029/17-173	M39029/17-20-20	20-24
	20	20	S	M39029/22-192	M39029/22-20-20	20-24
	22	22	S	M39029/22-191	M39029/22-22-22	22-28
	22	28	S	M39029/22-190	M39029/22-22-28	28-32
	23	22	P	M39029/18-177	M39029/18-23-22	22-28
	23	22	S	M39029/17-172	M39029/17-23-22	22-28
	23	28	P	M39029/18-176	M39029/18-23-28	28-32
	23	28	S	M39029/17-171	M39029/17-23-28	28-32

TOOL SELECTION		CRIMP TOOL AND ACCESSORY					ASSEMBLY TOOLS	
BIN*	COLOR	AF8	AFM8	MH860	WA23 (POS)	WA23 (DIE)	INSTALLING	REMOVAL
180 175	BROWN-GRAY-BLACK BROWN-VIOLET-GREEN	TP360 TP365					M81969/16-03 M81969/16-03	M81969/16-03 M81969/16-03
179 174	BROWN-VIOLET-WHITE BROWN-VIOLET-YELLOW		K341 K343	86-2 86-2			M81969/16-02 M81969/16-02	M81969/16-02 M81969/16-02
193 178	BROWN-WHITE-ORANGE BROWN-VIOLET-GRAY	TH343	K340	86-21 86-1S			M81969/16-02 M81969/16-01	M81969/16-02 M81969/16-01
173 192	BROWN-VIOLET-ORANGE BROWN-WHITE-RED	TH343	K342 K503	86-1S 86-20			M81969/16-01 M81969/16-01	M81969/16-01 M81969/16-01
191 190	BROWN-WHITE-BROWN BROWN-WHITE-BLACK		K330-3 K330-3	86-19 86-19			M81969/16-04 M81969/16-04	M81969/16-04 M81969/16-04
177 172	BROWN-VIOLET-VIOLET BROWN-VIOLET-RED		K338 K339				M81969/16-04 M81969/16-04	M81969/16-04 M81969/16-04
176 171	BROWN-VIOLET-BLUE BROWN-VIOLET-BROWN		K338 K339				M81969/16-04 M81969/16-04	M81969/16-04 M81969/16-04

*The three number suffix on M39029 series contacts is referred to as a "BIN" code. See page 27 for color stripe association.

**Scoop proof when pins are installed in the receptacle, but not when pins are installed in the plug.

Contact M39029/19-181 (Shielded Pin) #16 cavity, see page 86.
 Contact M39029/19-182 to 183 (Shielded Pin) #12 cavity, see page 86.
 Contact M39029/20-184 (Shielded Socket) #16 cavity, see page 86.
 Contact M39029/20-185 to 186 (Shielded Socket) #12 cavity, see page 86.

DMC does not provide connectors, contacts or wiring components. Parts shown here are for reference only. See disclaimer of liability on page 27.

SAE AS81511

SERIES 4



50% SCOOP PROOF**
CIRCULAR
REAR RELEASE CONTACTS

CONNECTOR P/N	DESCRIPTION	QPL SOURCES
M81511/51	FLANGE MOUNT RECEPTACLE	TE/DEUTSCH
M81511/53	JAM NUT MOUNT RECEPTACLE	
M81511/55	CABLE CONNECTING RECEPTACLE	
M81511/56	STRAIGHT PLUG	

CONTACTS	SIZE (AWG)		PIN/SKT.	PART NUMBER* (CURRENT)	PART NUMBER (SUPERSEDED)	WIRE RANGE
	MATING END	WIRE BARREL				
 TYPICAL CONTACT CONFIGURATION	12	12	P	M39029/18-180	M39029/18-12-12	12-14
	12	12	S	M39029/16-170	M39029/16-12-12	12-14
	16	16	P	M39029/18-179	M39029/18-16-16	16-20
	16	16	S	M39029/16-169	M39029/16-16-16	16-20
	16	16	S	M39029/22-193	M39029/22-16-16	16-20
	20	20	P	M39029/18-178	M39029/18-20-20	20-24
	20	20	S	M39029/16-168	M39029/16-20-20	20-24
	20	20	S	M39029/22-192	M39029/22-20-20	20-24
	22	22	S	M39029/22-191	M39029/22-22-22	22-28
	22	28	S	M39029/22-190	M39029/22-22-28	28-32
	23	22	P	M39029/18-177	M39029/18-23-22	22-28
	23	22	S	M39029/16-167	M39029/16-23-22	22-28
	23	28	P	M39029/18-176	M39029/18-23-28	28-32
	23	28	S	M39029/16-166	M39029/16-23-28	28-32

TOOL SELECTION		CRIMP TOOL AND ACCESSORY					ASSEMBLY TOOLS	
BIN*	COLOR	AF8	AFM8	MH860	WA23 (POS)	WA23 (DIE)	INSTALLING	REMOVAL
180 170	BROWN-GRAY-BLACK BROWN-VIOLET-BLACK	TP360 TP360					M81969/16-03 M81969/16-03	M81969/16-03 M81969/16-03
179 169	BROWN-VIOLET-WHITE BROWN-BLUE-WHITE		K341 K341	86-2 86-2			M81969/16-02 M81969/16-02	M81969/16-02 M81969/16-02
193 178	BROWN-WHITE-ORANGE BROWN-VIOLET-GRAY		K340	86-21			M81969/16-02 M81969/16-01	M81969/16-02 M81969/16-01
168 192	BROWN-BLUE-GRAY BROWN-WHITE-RED	TH343	K340 K503	86-20			M81969/16-01 M81969/16-01	M81969/16-01 M81969/16-01
191 190	BROWN-WHITE-BROWN BROWN-WHITE-BLACK		K330-3 K330-3	86-19 86-19			M81969/16-04 M81969/16-04	M81969/16-04 M81969/16-04
177 167	BROWN-VIOLET-VIOLET BROWN-BLUE-VIOLET		K338 K338				M81969/16-04 M81969/16-04	M81969/16-04 M81969/16-04
176 166	BROWN-VIOLET-BLUE BROWN-BLUE-BLUE		K338 K338				M81969/16-04 M81969/16-04	M81969/16-04 M81969/16-04

*The three number suffix on M39029 series contacts is referred to as a "BIN" code. See page 27 for color stripe association.

**Scoop proof when pins are installed in the receptacle, but not when pins are installed in the plug.

Contact M39029/7-126 to 128 (Shielded Pin) #12 cavity, see page 86.
 Contact M39029/8-129 to 131 (Shielded Socket) #12 cavity, see page 86.
 Contact M39029/9-132 to 136 (Thermocouple Pin) #20 cavity.
 Contact M39029/9-129 to 131 (Shielded Socket) #16 cavity.
 Contact M39029/10-126 to 128 (Shielded Pin) #20 cavity.
 Contact M39029/10-129 to 131 (Shielded Socket) #16 cavity.

DMC does not provide connectors, contacts or wiring components. Parts shown here are for reference only. See disclaimer of liability on page 27.

MIL-DTL-81659

SERIES 1 (INACTIVE)

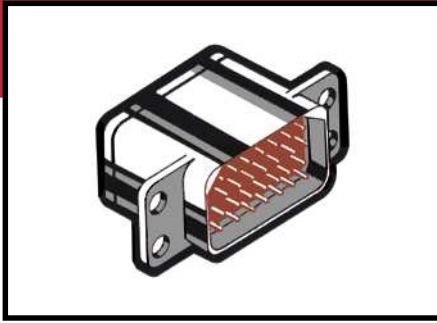

RECTANGULAR FRONT RELEASE CONTACTS

CONNECTOR P/N	DESCRIPTION	QPL SOURCES
M81659/1 THRU M81659/27	RECEPTACLE OR PLUG, TYPE 1 AND 2 CLASS 1 AND 2 SHELL DESIGNATOR A OR B	NO QPL SOURCES

CONTACTS	SIZE (AWG)		PIN/SKT.	PART NUMBER* (CURRENT)	PART NUMBER (SUPERSEDED)	WIRE RANGE
	MATING END	WIRE BARREL				
 TYPICAL CONTACT CONFIGURATION	16 16	16 16	P S	M39029/2-106 M39029/3-109	M39029/2-16-16 M39029/3-16-16	16-20 16-20
	20 20	20 20	P S	M39029/2-105 M39029/3-108	M39029/2-20-20 M39029/3-20-20	20-24 20-24
	22 22	22 22	P S	M39029/2-104 M39029/3-107	M39029/2-22-22 M39029/3-22-22	22-26 22-26

TOOL SELECTION		CRIMP TOOL AND ACCESSORY					ASSEMBLY TOOLS	
BIN*	COLOR	AF8	AFM8	MH860	WA23 (POS)	WA23 (DIE)	INSTALLING	REMOVAL
106 109	BROWN-BLACK-BLUE BROWN-BLACK-WHITE	TH1A TH1A		86-2 86-2			DAK55-16A DAK55-16A	DRK56-16A DRK56-16A
105 108	BROWN-BLACK-GREEN BROWN-BLACK-GRAY	TH1A TH1A	K287 K287				Consult DMC Consult DMC	Consult DMC Consult DMC
104 107	BROWN-BLACK-YELLOW BROWN-BLACK-VIOLET		K287 K287				Consult DMC Consult DMC	Consult DMC Consult DMC

*The three number suffix on M39029 series contacts is referred to as a "BIN" code. See page 27 for color stripe association.

DMC does not provide connectors, contacts or wiring components. Parts shown here are for reference only. See disclaimer of liability on page 27.

SAE AS81659 SERIES 2 (ARINC 404)

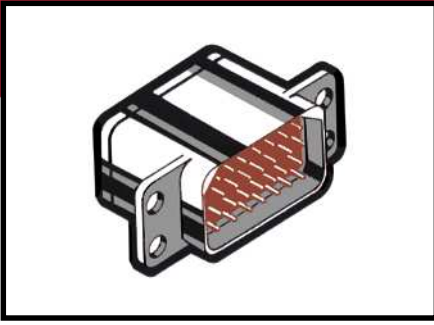

RECTANGULAR REAR RELEASE CONTACTS

CONNECTOR P/N	DESCRIPTION	QPL SOURCES
M81659/29 THRU M81659/72	RECEPTACLE OR PLUG, TYPE 2, 3 AND 4 CLASS 1 AND 2 SHELL DESIGNATOR A OR B	ITT CANNON RADIALL, S.A.

CONTACTS	SIZE (AWG)		PIN/SKT.	PART NUMBER* (CURRENT)	PART NUMBER (SUPERSEDED)	WIRE RANGE	
	MATING END	WIRE BARREL					
	12	12	P	M39029/11-147	M39029/11-12-12	12-14	
	12	12	S	M39029/12-151	M39029/12-12-12	12-14	
	16	16	P	M39029/11-146	M39029/11-16-16	16-20	
	16	16	S	M39029/12-150	M39029/12-16-16	16-20	
	20	20	P	M39029/11-145	M39029/11-20-20	20-24	
	20	20	S	M39029/12-149	M39029/12-20-20	20-24	
	TYPICAL CONTACT CONFIGURATION	22	22	P	M39029/11-144	M39029/11-22-22	22-26
		22	22	S	M39029/12-148	M39029/12-22-22	22-26

TOOL SELECTION		CRIMP TOOL AND ACCESSORY					ASSEMBLY TOOLS	
BIN*	COLOR	AF8	AFM8	MH860	WA23 (POS)	WA23 (DIE)	INSTALLING	REMOVAL
147 151	BROWN-YELLOW-VIOLET BROWN-GREEN-BROWN	TP465 TP465					None Designated None Designated	DRK337 DRK337
146 150	BROWN-YELLOW-BLUE BROWN-GREEN-BLACK	TH1A TH1A		86-2 86-2			M81969/1-03 M81969/1-03	M81969/1-03 M81969/1-03
145 149	BROWN-YELLOW-GREEN BROWN-YELLOW-WHITE		K13-1 K13-1	86-30-1 86-30-1			M81969/1-02 M81969/1-02	M81969/1-02 M81969/1-02
144 148	BROWN-YELLOW-YELLOW BROWN-YELLOW-GRAY		K267-1 K267-1	86-137 86-137			M81969/1-01 M81969/1-01	M81969/1-01 M81969/1-01

*The three number suffix on M39029 series contacts is referred to as a "BIN" code. See page 27 for color stripe association.

DMC does not provide connectors, contacts or wiring components. Parts shown here are for reference only. See disclaimer of liability on page 27.

MIL-C-81703

SERIES 3

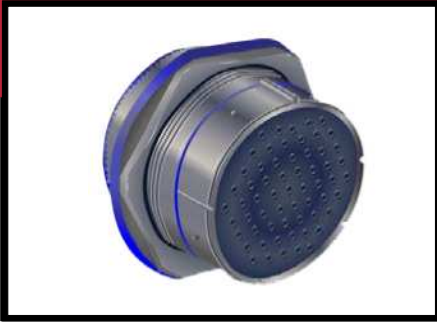

CIRCULAR RACK & PANEL OR PUSH PULL COUPLING REAR RELEASE CONTACTS

CONNECTOR P/N	DESCRIPTION	QPL SOURCES
MS3445	PLUG RACK & PANEL	TE/DEUTSCH
MS3424	WALL MOUNT FLANGE RECEPTACLE	
MS3446	PLUG RACK & PANEL	
MS3464	JAM NUT MOUNT RECEPTACLE	
MS3467	STRAIGHT PLUG	
MS3468	PLUG LANYARD COUPLING	

CONTACTS	SIZE (AWG)		PIN/SKT.	PART NUMBER* (CURRENT)	PART NUMBER (SUPERSEDED)	WIRE RANGE
	MATING END	WIRE BARREL				
<p>TYPICAL CONTACT CONFIGURATION</p>	12	12	P	M39029/4-113	M39029/4-12-12	12-14
	12	12	S	M39029/5-118	M39029/5-12-12	12-14
	12	16	P	M39029/4-114	M39029/4-12-16	16-20
	12	16	S	M39029/5-119	M39029/5-12-16	16-20
	16	16	P	M39029/4-111	M39029/4-16-16	16-20
	16	16	S	M39029/5-116	M39029/5-16-16	16-20
	16	20	P	M39029/4-112	M39029/4-16-20	20-24
	16	20	S	M39029/5-117	M39029/5-16-20	20-24
	20	20	P	M39029/4-110	M39029/4-20-20	20-24
	20	20	S	M39029/5-115	M39029/5-20-20	20-24

TOOL SELECTION		CRIMP TOOL AND ACCESSORY					ASSEMBLY TOOLS	
BIN*	COLOR	AF8	AFM8	MH860	WA23 (POS)	WA23 (DIE)	INSTALLING	REMOVAL
113	BROWN-BROWN-ORANGE	TH1A					DAK83-12B	DRK83-12B
118	BROWN-BROWN-GRAY	TH1A					DAK83-12B	DRK83-12B
114	BROWN-BROWN-YELLOW	TH1A					DAK83-12B	DRK83-12B
119	BROWN-BROWN-WHITE	TH1A					DAK83-12B	DRK83-12B
111	BROWN-BROWN-BROWN	TH1A		86-2			DAK83-16B	DRK83-16B
116	BROWN-BROWN-BLUE	TH1A		86-2			DAK83-16B	DRK83-16B
112	BROWN-BROWN-RED	TH1A	K1S	86-2			DAK83-16B	DRK83-16B
117	BROWN-BROWN-VIOLET	TH1A	K1S	86-2			DAK83-16B	DRK83-16B
110	BROWN-BROWN-BLACK	TH1A	K1S	86-1S			DAK83-20B	DRK83-20B
115	BROWN-BROWN-GREEN	TH1A	K1S	86-1S			DAK83-20B	DRK83-20B

*The three number suffix on M39029 series contacts is referred to as a "BIN" code. See page 27 for color stripe association.

Contact M39029/7-126 to 128 (Shielded Pin) #12 cavity, see page 86.
 Contact M39029/8-129 to 131 (Shielded Socket) #12 cavity, see page 86.
 Contact M39029/9-132 to 136 (Thermocouple Pin) #20 cavity.
 Contact M39029/9-129 to 131 (Shielded Socket) #16 cavity.
 Contact M39029/10-126 to 128 (Shielded Pin) #20 cavity.
 Contact M39029/10-129 to 131 (Shielded Socket) #16 cavity.

DMC does not provide connectors, contacts or wiring components. Parts shown here are for reference only. See disclaimer of liability on page 27.

SAE AS81714 SERIES 1

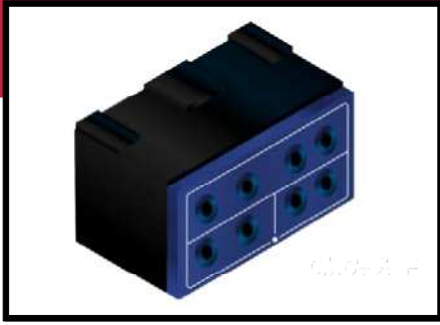

TERMINAL JUNCTIONS

CONNECTOR P/N	DESCRIPTION	QPL SOURCES
M81714/60	FEEDBACK TYPE, BUSSING MODULES	AMPHENOL PCD, AMP TYCO, TE CONNECTIVITY, DME ELECTRONICS
M81714/61	FEEDBACK TYPE, BUSSING MODULES	
M81714/63	STUD MOUNTED, SECTIONAL GROUNDING MODULES	
M81714/65	IN-LINE WIRE TO WIRE JUNCTIONS	
M81714/67	TRACK MOUNT (RACK ASSEMBLY)	

CONTACTS	SIZE (AWG)		PIN/SKT.	PART NUMBER* (CURRENT)	PART NUMBER (SUPERSEDED)	WIRE RANGE
	MATING END	WIRE BARREL				
 TYPICAL CONTACT CONFIGURATION	12	12	P	M39029/1-103 M39029/1-102	M39029/1-12-12 M39029/1-14-16	12-14 16-20
	14	16	P			
	16	20	P	M39029/1-101 M39029/1-100	M39029/1-16-20 M39029/1-16-22	20-24 22-26
	16	22	P			
	20	22D	P	M39029/1-507	M39029/1-20-22D	22-28

TOOL SELECTION		CRIMP TOOL AND ACCESSORY					ASSEMBLY TOOLS	
BIN*	COLOR	AF8	AFM8	MH860	WA23 (POS)	WA23 (DIE)	INSTALLING	REMOVAL
103	BROWN-BLACK-ORANGE	TH1A					DAK83-12B	DRK83-12B
102	BROWN-BLACK-RED	TH1A					DAK83-16B	DRK83-16B
101	BROWN-BLACK-BROWN	TH1A	K287				DAK83-20B	DRK83-20B
100	BROWN-BLACK-BLACK		K287				M81969/14-11	M81969/14-11
507	GREEN-BLACK-VIOLET		K496-1				M81969/14-01	M81969/14-01

*The three number suffix on M39029 series contacts is referred to as a "BIN" code. See page 27 for color stripe association.

DMC does not provide connectors, contacts or wiring components. Parts shown here are for reference only. See disclaimer of liability on page 27.



SAE AS81714 SERIES 2

COMMON TERMINATION SYSTEM

CONNECTOR P/N	DESCRIPTION	QPL SOURCES
M81714/60	FEEDBACK TYPE, BUSSING MODULES	AMPHENOL PCD, AMP TYCO, TE CONNECTIVITY, DME ELECTRONICS
M81714/61	FEEDBACK TYPE, BUSSING MODULES	
M81714/63	STUD MOUNTED, SECTIONAL GROUNDING MODULES	
M81714/65	IN-LINE WIRE TO WIRE JUNCTIONS	
M81714/67	TRACK MOUNT (RACK ASSEMBLY)	

CONTACTS	SIZE (AWG)		PIN/SKT.	PART NUMBER* (CURRENT)	PART NUMBER (SUPERSEDED)	WIRE RANGE
	MATING END	WIRE BARREL				
	12 16	12 16	S S	M39029/22-605 M39029/22-193	— M39029/22-16-16	12-14 16-20
	20 22	20 22	S S	M39029/22-192 M39029/22-191	M39029/22-20-20 M39029/22-22-22	20-24 28-32
	22	28	S	M39029/22-190	M39029/22-22-28	28-32
TYPICAL CONTACT CONFIGURATION						

TOOL SELECTION		CRIMP TOOL AND ACCESSORY					ASSEMBLY TOOLS	
BIN*	COLOR	AF8	AFM8	MH860	WA23 (POS)	WA23 (DIE)	INSTALLING	REMOVAL**
605 193	BLUE-BLACK-GREEN BROWN-WHITE-ORANGE	TH343 TH343		86-21			DAK83-12B DAK83-16B	DRK83-12B DRK83-16B
192 191	BROWN-WHITE-RED BROWN-WHITE-BROWN	TH343	K503 K330-3	86-20 86-19			DAK83-20B M81969/14-01	DRK83-20B M81969/14-01
190	BROWN-WHITE-BLACK		K330-3	86-19			M81969/14-01	M81969/14-01

*The three number suffix on M39029 series contacts is referred to as a "BIN" code. See page 27 for color stripe association.

**M81714/69 is a module removal tool (used to remove terminal junction blocks from the rack/carrier).

DMC does not provide connectors, contacts or wiring components. Parts shown here are for reference only. See disclaimer of liability on page 27.

MIL-DTL-83527 (ARINC 600)

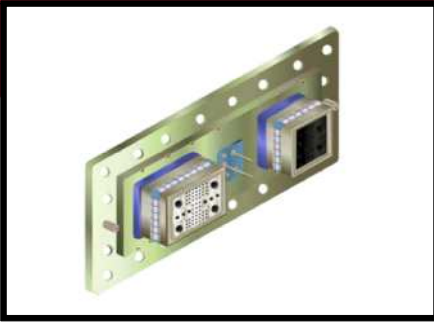

RECTANGULAR RACK AND PANEL REAR RELEASE CONTACTS

CONNECTOR P/N	DESCRIPTION	QPL SOURCES
M83527/1 THRU M83527/6	Receptacle or Plug Shell Size 2, 3, 4	Tyco Electronics (AMP) Souriau ITT Cannon

CONTACTS	SIZE (AWG)		PIN/SKT.	PART NUMBER* (CURRENT)	PART NUMBER (SUPERSEDED)	WIRE RANGE
	MATING END	WIRE BARREL				
 TYPICAL CONTACT CONFIGURATION	22	22	P	M39029/93-597		22-26
	22	22	S	M39029/94-601		22-26
	20	20	P	M39029/93-598		20-24
	20	20	S	M39029/94-602		20-24
	16	16	P	M39029/93-539		16-20
	16	16	S	M39029/94-603		16-20
	12	12	P	M39029/93-540		12-14
	12	12	S	M39029/94-604		12-14

TOOL SELECTION		CRIMP TOOL AND ACCESSORY					ASSEMBLY TOOLS	
BIN*	COLOR	AF8	AFM8	MH860	WA23 (POS)	WA23 (DIE)	INSTALLING	REMOVAL
597	GREEN-WHITE-VIOLET		K267-1	86-137			M81969/1-01	M81969/1-01
601	BLUE-BLACK-BROWN		K267-1	86-137			M81969/1-01	M81969/1-01
598	GREEN-WHITE-GRAY	TP585	K13-1	86-30-1			M81969/1-02	M81969/1-02
602	BLUE-BLACK-RED	TP585	K13-1	86-30-1			M81969/1-02	M81969/1-02
539	GREEN-ORANGE-WHITE	TH1A		86-2			M81969/1-03	M81969/1-03
603	BLUE-BLACK-ORANGE	TH1A		86-2			M81969/1-03	M81969/1-03
540	GREEN-YELLOW-BLACK	TP465						DRK337
604	BLUE-BLACK-YELLOW	TP465						DRK337

*The three number suffix on M39029 series contacts is referred to as a "BIN" code. See page 27 for color stripe association.

Contact M39029/95-545 (Shielded Socket) #8 Cavity, consult DMC for status.
 Contact M39029/96-546 (Shielded Pin) #8 Cavity, consult DMC for status.
 Contact M39029/97-547 (Shielded Pin) #1 Cavity, consult DMC for status.
 Contact M39029/98-548 (Shielded Socket) #1 Cavity, consult DMC for status.
 Contact M39029/99-549 (Shielded Socket) #5 Cavity, consult DMC for status.
 Contact M39029/100-550 (Shielded Socket) #5 Cavity, consult DMC for status.

DMC does not provide connectors, contacts or wiring components. Parts shown here are for reference only. See disclaimer of liability on page 27.

MIL-DTL-83723 SERIES 2

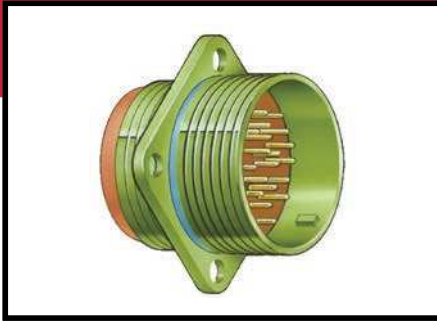

CIRCULAR THREADED COUPLING REAR RELEASE CONTACTS

CONNECTOR P/N	DESCRIPTION	QPL SOURCES
M83723/17	CABLE CONNECTING RECEPTACLE SOCKET CONTACTS	AERO-ELECTRIC, AMPHENOL, ITT CANNON
M83723/18	CABLE CONNECTING RECEPTACLE PIN CONTACTS	
M83723/19	WALL MOUNT RECEPTACLE SOCKET CONTACTS	
M83723/20	WALL MOUNT RECEPTACLE PIN CONTACTS	
M83723/21	BOX MOUNT RECEPTACLE SOCKET CONTACTS	
M83723/22	BOX MOUNT RECEPTACLE PIN CONTACTS	
M83723/23	PLUG SOCKET CONTACTS	
M83723/24	PLUG PIN CONTACTS	

CONTACTS	SIZE (AWG)		PIN/SKT.	PART NUMBER* (CURRENT)	PART NUMBER (SUPERSEDED)	WIRE RANGE
	MATING END	WIRE BARREL				
	12	12	P	M39029/29-213	M39029/29-12-12	12-14
	12	12	S	M39029/30-219	M39029/30-12-12	12-14
TYPICAL CONTACT CONFIGURATION	16	16	P	M39029/29-212	M39029/29-16-16	16-20
	16	16	S	M39029/30-218	M39029/30-16-16	16-20

TOOL SELECTION		CRIMP TOOL AND ACCESSORY					ASSEMBLY TOOLS	
BIN*	COLOR	AF8	AFM8	MH860	WA23 (POS)	WA23 (DIE)	INSTALLING	REMOVAL
213 219	RED-BROWN-ORANGE RED-BROWN-WHITE	TH1A TH1A					DAK83-12B DAK83-12B	DRK83-12B DRK83-12B
212 218	RED-BROWN-RED RED-BROWN-GRAY	TH1A TH1A		86-2 86-2			DAK83-16B DAK83-16B	DRK83-16B DRK83-16B

*The three number suffix on M39029 series contacts is referred to as a "BIN" code. See page 27 for color stripe association. Contacts M39029/85 and /86 are Thermocouples. Consult DMC for more info.

DMC does not provide connectors, contacts or wiring components. Parts shown here are for reference only. See disclaimer of liability on page 27.

MIL-DTL-83723 SERIES 3

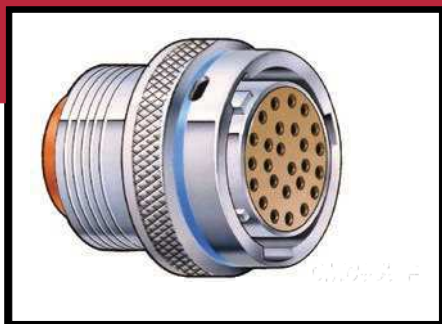

CIRCULAR BAYONET AND THREADED COUPLING REAR RELEASE CONTACTS

CONNECTOR P/N	DESCRIPTION	QPL SOURCES
M83723/71, /72, /82, /83,	FLANGE MOUNT RECEPTACLE	AERO ELECTRIC, AMPHENOL, PYLE NATIONAL, TE CONNECTIVITY, J-TECH, HI-REL CONNECTORS, ITT CANNON, JOURIAU
M83723/73, 74, /84, /85	JAM NUT RECEPTACLE	
M83723/75, 76, /77	STRAIGHT PLUG, BAYONET	
M83723/78, /86, 87, /91, /92, /95, /96	STRAIGHT PLUG, THREADED	

CONTACTS	SIZE (AWG)		PIN/SKT.	PART NUMBER* (CURRENT)	PART NUMBER (SUPERSEDED)	WIRE RANGE
	MATING END	WIRE BARREL				
 TYPICAL CONTACT CONFIGURATION	12	12	P	M39029/4-113	M39029/4-12-12 or M83723-33B12	12-14
	12	12	S	M39029/5-118	M39029/5-12-12 or M83723-34B12	12-14
	12 12	16 16	P S	M39029/4-114 M39029/5-119	M39029/4-12-16 or M39029/5-12-16	16-20 16-20
	16	16	P	M39029/4-111	M39029/4-16-16 or M83723-33B16	16-20
	16	16	S	M39029/5-116	M39029/5-16-16 or M83723-34B16	16-20
	16 16	20 20	P S	M39029/4-112 M39029/5-117	M39029/4-16-20 or M39029/5-16-20	20-24 20-24
	20	20	P	M39029/4-110	M39029/4-20-20 or M83723-33B20	20-24
	20	20	S	M39029/5-115	M39029/5-20-20 or M83723-34B20	20-24

TOOL SELECTION		CRIMP TOOL AND ACCESSORY					ASSEMBLY TOOLS	
BIN*	COLOR	AF8	AFM8	MH860	WA23 (POS)	WA23 (DIE)	INSTALLING	REMOVAL
113	BROWN-BROWN-ORANGE	TH1A					DAK83-12B	DRK83-12B
118	BROWN-BROWN-GRAY	TH1A					DAK83-12B	DRK83-12B
114 119	BROWN-BROWN-YELLOW BROWN-BROWN-WHITE	TH1A TH1A		86-2 86-2			DAK83-16B DAK83-16B	DRK83-16B DRK83-16B
111	BROWN-BROWN-BROWN	TH1A		86-2			DAK83-16B	DRK83-16B
116	BROWN-BROWN-BLUE	TH1A		86-2			DAK83-16B	DRK83-16B
112 117	BROWN-BROWN-RED BROWN-BROWN-VIOLET	TH1A TH1A		86-2 86-2			DAK83-16B DAK83-16B	DRK83-16B DRK83-16B
110	BROWN-BROWN-BLACK	TH1A	K1S	86-1S			DAK83-20B	DRK83-20B
115	BROWN-BROWN-GREEN	TH1A	K1S	86-1S			DAK83-20B	DRK83-20B

*The three number suffix on M39029 series contacts is referred to as a "BIN" code. See page 27 for color stripe association.

Contact M39029/50 to 340 (Shielded Pin) #12 cavity, see page 87.
 Contact M39029/51-341 to 415 (Shielded Socket) #12 cavity, see page 87.
 Contact M39029/73-396 to 398 (Shielded Socket) #12 cavity, solder termination.
 Contact M39029/74-399 to 401 (Shielded Pin) #12 cavity, solder termination.

DMC does not provide connectors, contacts or wiring components. Parts shown here are for reference only. See disclaimer of liability on page 27.

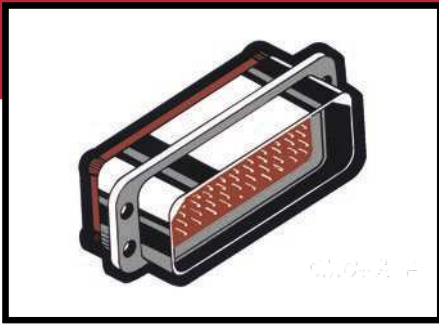

MIL-DTL-83733

RECTANGULAR MINIATURE RACK AND PANEL REAR RELEASE CONTACTS

CONNECTOR P/N	DESCRIPTION	QPL SOURCES
M83733/1	STANDARD HOLE MOUNT	DELPHI CONNECTION SYSTEMS
M83733/2	GUIDE PINS AND SPRING MOUNT	
M83733/3	GUIDE SOCKETS	
M83733/4	CAPTIVE SPRINGS	
M83733/5	BUSHING MOUNT	
M83733/6	CLINCH NUT MOUNT	
M83733/7	GUIDE SOCKETS AND SPRING MOUNT	
M83733/8	GUIDE PINS	
M83733/9	STAGGERED STANDARD HOLE MOUNT	
M83733/10	STAGGERED BUSHING MOUNT	
M83733/11	STAGGERED CLINCH NUT MOUNT	
M83733/12	STAGGERED SPRING MOUNT	

CONTACTS	SIZE (AWG)		PIN/SKT.	PART NUMBER* (CURRENT)	PART NUMBER (SUPERSEDED)	WIRE RANGE
	MATING END	WIRE BARREL				
<p>TYPICAL CONTACT CONFIGURATION</p>	12	12	P	M39029/4-113	M39029/4-12-12	12-14
	12	12	S	M39029/5-118	M39029/5-12-12	12-14
	16	16	P	M39029/4-111	M39029/4-16-16	16-20
	16	16	S	M39029/5-116	M39029/5-16-16	16-20
	20	20	P	M39029/4-110	M39029/4-20-20	20-24
	20	20	S	M39029/5-115	M39029/5-20-20	20-24
	22	22D	P	M39029/58-360	MS27494-22D	22-28
	22	22D	S	M39029/57-354	MS27492-22D	22-28

TOOL SELECTION		CRIMP TOOL AND ACCESSORY					ASSEMBLY TOOLS	
BIN*	COLOR	AF8	AFM8	MH860	WA23 (POS)	WA23 (DIE)	INSTALLING	REMOVAL
113	BROWN-BROWN-ORANGE	TH1A					M81969/14-04	M81969/14-04
118	BROWN-BROWN-GRAY	TH1A					M81969/14-04	M81969/14-04
111	BROWN-BROWN-BROWN	TH1A		86-2			M81969/14-03	M81969/14-03
116	BROWN-BROWN-BLUE	TH1A		86-2			M81969/14-03	M81969/14-03
110	BROWN-BROWN-BLACK	TH1A	K1S	86-1S			M81969/14-02	M81969/14-02
115	BROWN-BROWN-GREEN	TH1A	K1S	86-1S			M81969/14-02	M81969/14-02

*The three number suffix on M39029 series contacts is referred to as a "BIN" code. See page 27 for color stripe association.

Contact M39029/50-340 (Shielded Pin) #12 cavity, see page 87.
 Contact M39029/51-341 (Shielded Socket) #12 cavity, see page 87.
 Contact M39029/87 is a Thermocouple.
 Contact M39029/89 is a Thermocouple.

DMC does not provide connectors, contacts or wiring components. Parts shown here are for reference only. See disclaimer of liability on page 27.

SAE AS85028



**RECTANGULAR – INDIVIDUAL CONTACT SEALING
POLARIZED CENTER JACK SCREW
PULL THRU INSERTION CONTACTS****

CONNECTOR P/N	DESCRIPTION	QPL SOURCES
M85028/1	CRIMP REMOVABLE PIN CONTACTS	DELPHI CONNECTION SYSTEMS
M85028/2	CRIMP REMOVABLE SOCKET CONTACTS	

CONTACTS	SIZE (AWG)		PIN/SKT.	PART NUMBER* (CURRENT)	PART NUMBER (SUPERSEDED)	WIRE RANGE
	MATING END	WIRE BARREL				
 TYPICAL CONTACT CONFIGURATION	16	16	P	M39029/70-389	M39029/70-3	16-20
	16	16	S	M39029/69-386	M39029/69-3	16-20
	16	20	P	M39029/70-388	M39029/70-2	20-24
	16	20	S	M39029/69-385	M39029/69-2	20-24
	16	24	P	M39029/70-387	M39029/70-1	24-28
	16	24	S	M39029/69-384	M39029/69-1	24-28

TOOL SELECTION		CRIMP TOOL AND ACCESSORY					ASSEMBLY TOOLS	
BIN*	COLOR	AF8	AFM8	MH860	WA23 (POS)	WA23 (DIE)	INSTALLING**	REMOVAL
389	ORANGE-GRAY-WHITE	TP651					DAK1-16P	DRK222
386	ORANGE-GRAY-BLUE	TP651					DAK1-16S	DRK222
388	ORANGE-GRAY-GRAY	TP651					DAK1-16P	DRK222
385	ORANGE-GRAY-GREEN	TP651					DAK1-16S	DRK222
387	ORANGE-GRAY-VIOLET	TP651					DAK1-16P	DRK222
384	ORANGE-GRAY-YELLOW	TP651					DAK1-16S	DRK222

*The three number suffix on M39029 series contacts is referred to as a "BIN" code. See page 27 for color stripe association.

** Due to the sealing grommet on the contact wire barrel, it requires a special tool which is inserted through the connector, attached to the mating end of the contact, and then "pulled" into the connector. A release on the tool is actuated and the tool can be removed from the contact.

DMC does not provide connectors, contacts or wiring components. Parts shown here are for reference only. See disclaimer of liability on page 27.



SAE AS95234

REVERSE BAYONET

CONNECTOR P/N	DESCRIPTION	QPL SOURCES
AS95234/1	RECEPTACLE, BAYONET COUPLING, IN LINE	SPACECRAFT (NON-QPL SOURCE)
AS95234/2	RECEPTACLE, SQUARE FLANGE, BOX MOUNT, FRONT	
AS95234/3	RECEPTACLE, SQUARE FLANGE, BOX MOUNT, REAR	
AS95234/4	RECEPTACLE, SQUARE FLANGE, PANEL MOUNT, FRONT	
AS95234/5	RECEPTACLE, SQUARE FLANGE, PANEL MOUNT, REAR	
AS95234/6	PLUG, REVERSE BAYONET COUPLING	
AS95234/7	RECEPTACLE, JAM NUT	
AS95234/8	RECEPTACLE, JAM NUT	
AS95234/9	PLUG, GROUNDING	

CONTACTS	SIZE (AWG)		PIN/SKT.	PART NUMBER* (CURRENT)	PART NUMBER (SUPERSEDED)	WIRE RANGE
	MATING END	WIRE BARREL				
<p>TYPICAL CONTACT CONFIGURATION</p>	0	0	P	M39029/44-293	MS90453-0-0	0-2
	0	0	S	M39029/45-300	MS90454-0-0	0-2
	4	4	P	M39029/44-292	MS90453-4-0	4-6
	4	4	S	M39029/45-299	MS90454-4-0	4-6
	8	8	P	M39029/44-291	MS90453-8-0	8-10
	8	8	S	M39029/45-298	MS90454-8-0	8-10
	12	12	P	M39029/44-290	MS90453-12-12	12-14
	12	12	S	M39029/45-297	MS90454-12-12	12-14
	12	16	P	M39029/44-289	MS90453-12-16	16-20
	12	16	S	M39029/45-296	MS90454-12-16	16-20
	16	16	P	M39029/44-288	MS90453-16-16	16-20
	16	16	S	M39029/45-295	MS90454-16-16	16-20
	16	22	P	M39029/44-287	MS90453-16-22	22-26
	16	22	S	M39029/45-294	MS90454-16-22	22-26

TOOL SELECTION		CRIMP TOOL AND ACCESSORY					ASSEMBLY TOOLS	
BIN*	COLOR	AF8	AFM8	MH860	WA23 (POS)	WA23 (DIE)	INSTALLING	REMOVAL
293 300	RED-WHITE-ORANGE ORANGE-BLACK-BLACK				WA23-13 WA23-13	WA23-5 WA23-5	DAK55-0B DAK55-0B	DRK56-0B DRK56-0B
292 299	RED-WHITE-RED RED-WHITE-WHITE				WA23-11 WA23-11	WA23-4 WA23-4	DAK55-4B DAK55-4B	DRK56-4B DRK56-4B
291 298	RED-WHITE-BROWN RED-WHITE-GRAY				WA23-9 WA23-9	WA23-2 WA23-2	DAK55-8B DAK55-8B	DRK56-8B DRK56-8B
290 297	RED-WHITE-BLACK RED-WHITE-VIOLET	TH1A TH1A					DAK55-12A DAK55-12A	DRK56-12A DRK56-12A
289 296	RED-GRAY-WHITE RED-WHITE-BLUE	TH1A TH1A					DAK55-12A DAK55-12A	DRK56-12A DRK56-12A
288 295	RED-GRAY-GRAY RED-WHITE-GREEN	TH1A TH1A		86-2 86-2			DAK55-16A DAK55-16A	DRK56-16A DRK56-16A
287 294	RED-GRAY-VIOLET RED-WHITE-YELLOW	TH1A TH1A		86-2 86-2			DAK55-16A DAK55-16A	DRK56-16A DRK56-16A

*The three number suffix on M39029 series contacts is referred to as a "BIN" code. See page 27 for color stripe association.

DMC does not provide connectors, contacts or wiring components. Parts shown here are for reference only. See disclaimer of liability on page 27.

MICRO CONNECTORS

SERIES 801 (PART 1 OF 2)



SPECIFICATIONS:

COUPLING METHOD: DOUBLE-START ACME THREAD CONNECTORS
KEYING POSITIONS: A (NORMAL), B, C, D, E, F

MANUFACTURER:
AMPHENOL
GLENAIR

SERIES:
2M801
801

SHELL MATERIAL	FINISH
Aluminum	Black Anodize, Electroless Nickel, Cadmium Olive Drab Chromate, Zinc-Nickel w/ Black Chromate, Zinc-Nickel w/ Olive Drab Chromate, Nickel-PTFE
Stainless Steel	Passivated

CONTACT MILITARY PART NUMBER	CONTACT PART NUMBER	CONTACT TYPE	CONTACT SIZE	WIRE SIZE	COLOR BAND			DESCRIPTION
--	809-001*/2M809-001**	P	23	22-28	N/A	N/A	N/A	Standard Size #23 BeCu Removable Crimp Contact
--	809-042*/2M809-042**	P	23	26-30	N/A	N/A	N/A	Small Bore Size #23 BeCu Removable Crimp Contact
--	809-002*/2M809-002**	S	23	22-28	N/A	N/A	N/A	Standard Size #23 BeCu Removable Crimp Contact
--	809-043*/2M809-043**	S	23	26-30	N/A	N/A	N/A	Small Bore Size #23 BeCu Removable Crimp Contact
--	809-204*/2M809-204**	P	20HD	20-24	N/A	N/A	N/A	Size #20HD Crimp Contact
--	809-205*/2M809-205**	S	20HD	20-24	N/A	N/A	N/A	Size #20HD Crimp Contact
M39029/58-363	850-002-20-363*	P	20	20-24	Orange	Blue	Orange	Size #20 Crimp Contact
M39029/57-357	850-002-20-357*	S	20	20-24	Orange	Green	Violet	Size #20 Crimp Contact
M39029/58-364	809-110*	P	16	16-20	Orange	Blue	Yellow	Size #16 Crimp Contact
M39029/57-358	809-111*	S	16	16-20	Orange	Green	Gray	Size #16 Crimp Contact
M39029/58-365	809-112*	P	12	12-14	Orange	Blue	Green	Size #12 Crimp Contact
M39029/57-359	809-113*	S	12	12-14	Orange	Green	White	Size #12 Crimp Contact
M39029/76-424	809-114*	P	16	RG174, RG316, RG179	Yellow	Red	Yellow	Size #16 Coaxial Contact
M39029/76-425	809-115*	P	16	RG178	Yellow	Red	Green	Size #16 Coaxial Contact
M39029/78-432	809-116*	S	16	RG174, RG316, RG179	Yellow	Orange	Red	Size #16 Coaxial Contact
M39029/78-433	809-117*	S	16	RG178	Yellow	Orange	Orange	Size #16 Coaxial Contact
M39029/28-211	809-118*	P	12	RG174, RG316, RG179	Red	Brown	Brown	Size #12 Coaxial Contact
M39029/28-409	809-119*	P	12	RG180	Yellow	Black	White	Size #12 Coaxial Contact
M39029/27-210	809-120*	S	12	RG174, RG316, RG179	Red	Brown	Black	Size #12 Coaxial Contact
M39029/27-402	809-121*	S	12	RG180	Yellow	Black	Red	Size #12 Coaxial Contact
M39029/59-366	852-006-08-366*	P	8	M17/095-RG180	Orange	Blue	Blue	Size #8 Coaxial Contacts
M39029/60-367	852-007-08-367*	P	8	M17/095-RG180	Orange	Blue	Violet	Size #8 Coaxial Contacts
M39029/113-625	853-003-08-625*	P	8	M17/176-00002	Blue	Red	Green	Size #8 Concentric Twinax Contact
M39029/114-628	853-004-08-628*	S	8	M17/176-00002	Blue	Red	Violet	Size #8 Concentric Twinax Contact

*Glenair part number

**Amphenol part number

CONTACT MILITARY PART NUMBER	CONTACT PART NUMBER (GLENAIR)	CONTACT PART NUMBER (AMPHENOL)	CRIMP TOOL	PNEUMATIC TOOL	POSITIONER (GLENAIR)	POSITIONER (AMPHENOL)	CRIMP TOOL #2	DIE/ POSITIONER	INSERTION TOOL	REMOVAL TOOL
--	809-001	2M809-001	AFM8	WA22	K1461	K1461-1	--	--	809-088	809-088
--	809-042	2M809-042	AFM8	WA22	K1989	K1989-1	--	--	809-088	809-088
--	809-002	2M809-002	AFM8	WA22	K1461	K1461-1	--	--	809-088	809-088
--	809-043	2M809-043	AFM8	WA22	K1989	K1989-1	--	--	809-088	809-088
--	809-204	2M809-204	AFM8	WA22	K1859	K1859-1	--	--	809-203	809-203
--	809-205	2M809-205	AFM8	WA22	K1859	K1859-1	--	--	809-203	809-203
M39029/58-363	850-002-20-363	--	AF8	WA27F	TH163	TH163	--	--	M81969/14-10	M81969/14-10
M39029/57-357	850-002-20-357	--	AF8	WA27F	TH163	TH163	--	--	M81969/14-10	M81969/14-10
M39029/58-364	809-110	--	AF8	WA27F	TH163	TH163	--	--	M81969/14-03	M81969/14-03
M39029/57-358	809-111	--	AF8	WA27F	TH163	TH163	--	--	M81969/14-03	M81969/14-03
M39029/58-365	809-112	--	AF8	WA27F	TH163	TH163	--	--	M81969/14-04	M81969/14-04
M39029/57-359	809-113	--	AF8	WA27F	TH163	TH163	--	--	M81969/14-04	M81969/14-04
M39029/76-424	809-114	--	AFM8	WA22	K532-1	K532-1	GS100-1	GP295	DAK95-16B	DRK95-16B

DMC does not provide connectors, contacts or wiring components. Parts shown here are for reference only. See disclaimer of liability on page 27.

MICRO CONNECTORS

SERIES 801 (PART 2 OF 2)



SPECIFICATIONS:

COUPLING METHOD: DOUBLE-START ACME THREAD CONNECTORS
KEYING POSITIONS: A (NORMAL), B, C, D, E, F

MANUFACTURER:
AMPHENOL
GLENAIR

SERIES:
 2M801
 801

SHELL MATERIAL	FINISH
Aluminum	Black Anodize, Electroless Nickel, Cadmium Olive Drab Chromate, Zinc-Nickel w/ Black Chromate, Zinc-Nickel w/ Olive Drab Chromate, Nickel-PTFE
Stainless Steel	Passivated

CONTACT MILITARY PART NUMBER	CONTACT PART NUMBER (GLENAIR)	CONTACT PART NUMBER (AMPHENOL)	CRIMP TOOL	PNEUMATIC TOOL	POSITIONER (GLENAIR)	POSITIONER (AMPHENOL)	CRIMP TOOL #2	DIE/ POSITIONER	INSERTION TOOL	REMOVAL TOOL
M39029/76-425	809-115	--	AFM8	WA22	K532-1	K532-1	GS100-1	GP295	DAK95-16B	DRK95-16B
M39029/78-432	809-116	--	AFM8	WA22	K532-1	K532-1	GS100-1	GP295	DAK95-16B	DRK95-16B
M39029/78-433	809-117	--	AFM8	WA22	K532-1	K532-1	GS100-1	GP295	DAK95-16B	DRK95-16B
M39029/28-211	809-118	--	AFM8	WA22	K323	K323	GS200-1	G2P330	DAK95-12B	DRK95-12B
M39029/28-409	809-119	--	AFM8	WA22	K323	K323	GS200-1	G2P330	DAK95-12B	DRK95-12B
M39029/27-210	809-120	--	AFM8	WA22	K323	K323	GS200-1	G2P330	DAK95-12B	DRK95-12B
M39029/27-402	809-121	--	AFM8	WA22	K323	K323	GS200-1	G2P330	DAK95-12B	DRK95-12B
M39029/59-366	852-006-08-366	--	AFM8	WA22	K406	K406	HX4	Y197	--	M81969/14-12
M39029/60-367	852-007-08-367	--	AFM8	WA22	K406	K406	HX4	Y197	--	M81969/14-12
M39029/113-625	853-003-08-625	--	AFM8	WA22	K709	K709	HX4	Y631	--	M81969/14-12
M39029/114-628	853-004-08-628	--	AFM8	WA22	K709	K709	HX4	Y631	--	M81969/14-12

Application Guide Contacts & Connectors

DMC does not provide connectors, contacts or wiring components. Parts shown here are for reference only. See disclaimer of liability on page 27.

MICRO CONNECTORS

SERIES 803 (PART 1 OF 2)



SPECIFICATIONS:
COUPLING METHOD: 1/4 TURN BAYONET COUPLING
KEYING POSITIONS: N (NORMAL), X, Y, Z

MANUFACTURER:
AMPHENOL
GLENAIR

SERIES:
2M803
803

SHELL MATERIAL	FINISH
Aluminum	Black Anodize, Electroless Nickel, Cadmium Olive Drab Chromate, Zinc-Nickel w/ Black Chromate, Zinc-Nickel w/ Olive Drab Chromate, Nickel-PTFE
Stainless Steel	Passivated

CONTACT MILITARY PART NUMBER	CONTACT PART NUMBER	CONTACT TYPE	CONTACT SIZE	WIRE SIZE	COLOR BAND			DESCRIPTION
--	809-001*/2M809-001**	P	23	22-28	N/A	N/A	N/A	Standard Size #23 BeCu Removable Crimp Contact
--	809-042*/2M809-042**	P	23	26-30	N/A	N/A	N/A	Small Bore Size #23 BeCu Removable Crimp Contact
--	809-002*/2M809-002**	S	23	22-28	N/A	N/A	N/A	Standard Size #23 BeCu Removable Crimp Contact
--	809-043*/2M809-043**	S	23	26-30	N/A	N/A	N/A	Small Bore Size #23 BeCu Removable Crimp Contact
--	809-204*/2M809-204**	P	20HD	20-24	N/A	N/A	N/A	Size #20HD Crimp Contact
--	809-205*/2M809-205**	S	20HD	20-24	N/A	N/A	N/A	Size #20HD Crimp Contact
M39029/58-363	850-002-20-363*	P	20	20-24	Orange	Blue	Orange	Size #20 Crimp Contact
M39029/57-357	850-002-20-357*	S	20	20-24	Orange	Green	Violet	Size #20 Crimp Contact
M39029/58-364	809-110*	P	16	16-20	Orange	Blue	Yellow	Size #16 Crimp Contact
M39029/57-358	809-111*	S	16	16-20	Orange	Green	Gray	Size #16 Crimp Contact
M39029/58-365	809-112*	P	12	12-14	Orange	Blue	Green	Size #12 Crimp Contact
M39029/57-359	809-113*	S	12	12-14	Orange	Green	White	Size #12 Crimp Contact
M39029/76-424	809-114*	P	16	RG174, RG316, RG179	Yellow	Red	Yellow	Size #16 Coaxial Contact
M39029/76-425	809-115*	P	16	RG178	Yellow	Red	Green	Size #16 Coaxial Contact
M39029/78-432	809-116*	S	16	RG174, RG316, RG179	Yellow	Orange	Red	Size #16 Coaxial Contact
M39029/78-433	809-117*	S	16	RG178	Yellow	Orange	Orange	Size #16 Coaxial Contact
M39029/28-211	809-118*	P	12	RG174, RG316, RG179	Red	Brown	Brown	Size #12 Coaxial Contact
M39029/28-409	809-119*	P	12	RG180	Yellow	Black	White	Size #12 Coaxial Contact
M39029/27-210	809-120*	S	12	RG174, RG316, RG179	Red	Brown	Black	Size #12 Coaxial Contact
M39029/27-402	809-121*	S	12	RG180	Yellow	Black	Red	Size #12 Coaxial Contact
M39029/59-366	852-006-08-366*	P	8	M17/095-RG180	Orange	Blue	Blue	Size #8 Coaxial Contacts
M39029/60-367	852-007-08-367*	P	8	M17/095-RG180	Orange	Blue	Violet	Size #8 Coaxial Contacts
M39029/113-625	853-003-08-625*	P	8	M17/176-00002	Blue	Red	Green	Size #8 Concentric Twinax Contact
M39029/114-628	853-004-08-628*	S	8	M17/176-00002	Blue	Red	Violet	Size #8 Concentric Twinax Contact

*Glenair part number

**Amphenol part number

CONTACT MILITARY PART NUMBER	CONTACT PART NUMBER (GLENAIR)	CONTACT PART NUMBER (AMPHENOL)	CRIMP TOOL	PNEUMATIC TOOL	POSITIONER (GLENAIR)	POSITIONER (AMPHENOL)	CRIMP TOOL #2	DIE/ POSITIONER	INSERTION TOOL	REMOVAL TOOL
--	809-001	2M809-001	AFM8	WA22	K1461	K1461-1	--	--	809-088	809-088
--	809-042	2M809-042	AFM8	WA22	K1989	K1989-1	--	--	809-088	809-088
--	809-002	2M809-002	AFM8	WA22	K1461	K1461-1	--	--	809-088	809-088
--	809-043	2M809-043	AFM8	WA22	K1989	K1989-1	--	--	809-088	809-088
--	809-204	2M809-204	AFM8	WA22	K1859	K1859-1	--	--	809-203	809-203
--	809-205	2M809-205	AFM8	WA22	K1859	K1859-1	--	--	809-203	809-203
M39029/58-363	850-002-20-363	--	AF8	WA27F	TH163	TH163	--	--	M81969/14-10	M81969/14-10
M39029/57-357	850-002-20-357	--	AF8	WA27F	TH163	TH163	--	--	M81969/14-10	M81969/14-10
M39029/58-364	809-110	--	AF8	WA27F	TH163	TH163	--	--	M81969/14-03	M81969/14-03
M39029/57-358	809-111	--	AF8	WA27F	TH163	TH163	--	--	M81969/14-03	M81969/14-03
M39029/58-365	809-112	--	AF8	WA27F	TH163	TH163	--	--	M81969/14-04	M81969/14-04
M39029/57-359	809-113	--	AF8	WA27F	TH163	TH163	--	--	M81969/14-04	M81969/14-04
M39029/76-424	809-114	--	AFM8	WA22	K532-1	K532-1	GS100-1	GP295	DAK95-16B	DRK95-16B

DMC does not provide connectors, contacts or wiring components. Parts shown here are for reference only. See disclaimer of liability on page 27.

MICRO CONNECTORS

SERIES 803 (PART 2 OF 2)



SPECIFICATIONS:

COUPLING METHOD: 1/4 TURN BAYONET COUPLING

KEYING POSITIONS: N (NORMAL), X, Y, Z

MANUFACTURER:

AMPHENOL

GLENAIR

SERIES:

2M803

803

SHELL MATERIAL	FINISH
Aluminum	Black Anodize, Electroless Nickel, Cadmium Olive Drab Chromate, Zinc-Nickel w/ Black Chromate, Zinc-Nickel w/ Olive Drab Chromate, Nickel-PTFE
Stainless Steel	Passivated

CONTACT MILITARY PART NUMBER	CONTACT PART NUMBER (GLENAIR)	CONTACT PART NUMBER (AMPHENOL)	CRIMP TOOL	PNEUMATIC TOOL	POSITIONER (GLENAIR)	POSITIONER (AMPHENOL)	CRIMP TOOL #2	DIE/ POSITIONER	INSERTION TOOL	REMOVAL TOOL
M39029/76-425	809-115	--	AFM8	WA22	K532-1	K532-1	GS100-1	GP295	DAK95-16B	DRK95-16B
M39029/78-432	809-116	--	AFM8	WA22	K532-1	K532-1	GS100-1	GP295	DAK95-16B	DRK95-16B
M39029/78-433	809-117	--	AFM8	WA22	K532-1	K532-1	GS100-1	GP295	DAK95-16B	DRK95-16B
M39029/28-211	809-118	--	AFM8	WA22	K323	K323	GS200-1	G2P330	DAK95-12B	DRK95-12B
M39029/28-409	809-119	--	AFM8	WA22	K323	K323	GS200-1	G2P330	DAK95-12B	DRK95-12B
M39029/27-210	809-120	--	AFM8	WA22	K323	K323	GS200-1	G2P330	DAK95-12B	DRK95-12B
M39029/27-402	809-121	--	AFM8	WA22	K323	K323	GS200-1	G2P330	DAK95-12B	DRK95-12B
M39029/59-366	852-006-08-366	--	AFM8	WA22	K406	K406	HX4	Y197	-	M81969/14-12
M39029/60-367	852-007-08-367	--	AFM8	WA22	K406	K406	HX4	Y197	-	M81969/14-12
M39029/113-625	853-003-08-625	--	AFM8	WA22	K709	K709	HX4	Y631	-	M81969/14-12
M39029/114-628	853-004-08-628	--	AFM8	WA22	K709	K709	HX4	Y631	-	M81969/14-12

DMC does not provide connectors, contacts or wiring components. Parts shown here are for reference only. See disclaimer of liability on page 27.

MICRO CONNECTORS

SERIES 804 (PART 1 OF 2)



SPECIFICATIONS:
COUPLING METHOD: PUSH-PULL QUICK-DISCONNECT
KEYING POSITIONS: A (NORMAL), B, C, D, E, F

MANUFACTURER: AMPHENOL
GLENAIR
SERIES: 2M804
 804

SHELL MATERIAL	FINISH
Aluminum	Black Anodize, Electroless Nickel, Cadmium Olive Drab Chromate, Zinc-Nickel w/ Black Chromate, Zinc-Nickel w/ Olive Drab Chromate, Nickel-PTFE
Stainless Steel	Passivated

CONTACT MILITARY PART NUMBER	CONTACT PART NUMBER	CONTACT TYPE	CONTACT SIZE	WIRE SIZE	COLOR BAND			DESCRIPTION
--	809-001*/2M809-001**	P	23	22-28	N/A	N/A	N/A	Standard Size #23 BeCu Removable Crimp Contact
--	809-042*/2M809-042**	P	23	26-30	N/A	N/A	N/A	Small Bore Size #23 BeCu Removable Crimp Contact
--	809-002*/2M809-002**	S	23	22-28	N/A	N/A	N/A	Standard Size #23 BeCu Removable Crimp Contact
--	809-043*/2M809-043**	S	23	26-30	N/A	N/A	N/A	Small Bore Size #23 BeCu Removable Crimp Contact
--	809-204*/2M809-204**	P	20HD	20-24	N/A	N/A	N/A	Size #20HD Crimp Contact
--	809-205*/2M809-205**	S	20HD	20-24	N/A	N/A	N/A	Size #20HD Crimp Contact
M39029/58-363	850-002-20-363*	P	20	20-24	Orange	Blue	Orange	Size #20 Crimp Contact
M39029/57-357	850-002-20-357*	S	20	20-24	Orange	Green	Violet	Size #20 Crimp Contact
M39029/58-364	809-110*	P	16	16-20	Orange	Blue	Yellow	Size #16 Crimp Contact
M39029/57-358	809-111*	S	16	16-20	Orange	Green	Gray	Size #16 Crimp Contact
M39029/58-365	809-112*	P	12	12-14	Orange	Blue	Green	Size #12 Crimp Contact
M39029/57-359	809-113*	S	12	12-14	Orange	Green	White	Size #12 Crimp Contact
M39029/76-424	809-114*	P	16	RG174, RG316, RG179	Yellow	Red	Yellow	Size #16 Coaxial Contact
M39029/76-425	809-115*	P	16	RG178	Yellow	Red	Green	Size #16 Coaxial Contact
M39029/78-432	809-116*	S	16	RG174, RG316, RG179	Yellow	Orange	Red	Size #16 Coaxial Contact
M39029/78-433	809-117*	S	16	RG178	Yellow	Orange	Orange	Size #16 Coaxial Contact
M39029/28-211	809-118*	P	12	RG174, RG316, RG179	Red	Brown	Brown	Size #12 Coaxial Contact
M39029/28-409	809-119*	P	12	RG180	Yellow	Black	White	Size #12 Coaxial Contact
M39029/27-210	809-120*	S	12	RG174, RG316, RG179	Red	Brown	Black	Size #12 Coaxial Contact
M39029/27-402	809-121*	S	12	RG180	Yellow	Black	Red	Size #12 Coaxial Contact
M39029/59-366	852-006-08-366*	P	8	M17/095-RG180	Orange	Blue	Blue	Size #8 Coaxial Contacts
M39029/60-367	852-007-08-367*	P	8	M17/095-RG180	Orange	Blue	Violet	Size #8 Coaxial Contacts
M39029/113-625	853-003-08-625*	P	8	M17/176-00002	Blue	Red	Green	Size #8 Concentric Twinax Contact
M39029/114-628	853-004-08-628*	S	8	M17/176-00002	Blue	Red	Violet	Size #8 Concentric Twinax Contact

*Glenair part number

**Amphenol part number

CONTACT MILITARY PART NUMBER	CONTACT PART NUMBER (GLENAIR)	CONTACT PART NUMBER (AMPHENOL)	CRIMP TOOL	PNEUMATIC TOOL	POSITIONER (GLENAIR)	POSITIONER (AMPHENOL)	CRIMP TOOL #2	DIE/ POSITIONER	INSERTION TOOL	REMOVAL TOOL
--	809-001	2M809-001	AFM8	WA22	K1461	K1461-1	--	--	809-088	809-088
--	809-042	2M809-042	AFM8	WA22	K1989	K1989-1	--	--	809-088	809-088
--	809-002	2M809-002	AFM8	WA22	K1461	K1461-1	--	--	809-088	809-088
--	809-043	2M809-043	AFM8	WA22	K1989	K1989-1	--	--	809-088	809-088
--	809-204	2M809-204	AFM8	WA22	K1859	K1859-1	--	--	809-203	809-203
--	809-205	2M809-205	AFM8	WA22	K1859	K1859-1	--	--	809-203	809-203
M39029/58-363	850-002-20-363*	--	AF8	WA27F	TH163	TH163	--	--	M81969/14-10	M81969/14-10
M39029/57-357	850-002-20-357*	--	AF8	WA27F	TH163	TH163	--	--	M81969/14-10	M81969/14-10
M39029/58-364	809-110*	--	AF8	WA27F	TH163	TH163	--	--	M81969/14-03	M81969/14-03
M39029/57-358	809-111*	--	AF8	WA27F	TH163	TH163	--	--	M81969/14-03	M81969/14-03
M39029/58-365	809-112*	--	AF8	WA27F	TH163	TH163	--	--	M81969/14-04	M81969/14-04
M39029/57-359	809-113*	--	AF8	WA27F	TH163	TH163	--	--	M81969/14-04	M81969/14-04
M39029/76-424	809-114	--	AFM8	WA22	K532-1	K532-1	GS100-1	GP295	DAK95-16B	DRK95-16B

DMC does not provide connectors, contacts or wiring components. Parts shown here are for reference only. See disclaimer of liability on page 27.

MICRO CONNECTORS

SERIES 804 (PART 2 OF 2)



SPECIFICATIONS:
COUPLING METHOD: PUSH-PULL QUICK-DISCONNECT
KEYING POSITIONS: A (NORMAL), B, C, D, E, F

MANUFACTURER:
AMPHENOL
GLENAIR

SERIES:
2M804
804

SHELL MATERIAL	FINISH
Aluminum	Black Anodize, Electroless Nickel, Cadmium Olive Drab Chromate, Zinc-Nickel w/ Black Chromate, Zinc-Nickel w/ Olive Drab Chromate, Nickel-PTFE
Stainless Steel	Passivated

CONTACT MILITARY PART NUMBER	CONTACT PART NUMBER (GLENAIR)	CONTACT PART NUMBER (AMPHENOL)	CRIMP TOOL	PNEUMATIC TOOL	POSITIONER (GLENAIR)	POSITIONER (AMPHENOL)	CRIMP TOOL #2	DIE/ POSITIONER	INSERTION TOOL	REMOVAL TOOL
M39029/76-425	809-115	--	AFM8	WA22	K532-1	K532-1	GS100-1	GP295	DAK95-16B	DRK95-16B
M39029/78-432	809-116	--	AFM8	WA22	K532-1	K532-1	GS100-1	GP295	DAK95-16B	DRK95-16B
M39029/78-433	809-117	--	AFM8	WA22	K532-1	K532-1	GS100-1	GP295	DAK95-16B	DRK95-16B
M39029/28-211	809-118	--	AFM8	WA22	K323	K323	GS200-1	G2P330	DAK95-12B	DRK95-12B
M39029/28-409	809-119	--	AFM8	WA22	K323	K323	GS200-1	G2P330	DAK95-12B	DRK95-12B
M39029/27-210	809-120	--	AFM8	WA22	K323	K323	GS200-1	G2P330	DAK95-12B	DRK95-12B
M39029/27-402	809-121	--	AFM8	WA22	K323	K323	GS200-1	G2P330	DAK95-12B	DRK95-12B
M39029/59-366	852-006-08-366	--	AFM8	WA22	K406	K406	HX4	Y197	--	M81969/14-12
M39029/60-367	852-007-08-367	--	AFM8	WA22	K406	K406	HX4	Y197	--	M81969/14-12
M39029/113-625	853-003-08-625	--	AFM8	WA22	K709	K709	HX4	Y631	--	M81969/14-12
M39029/114-628	853-004-08-628	--	AFM8	WA22	K709	K709	HX4	Y631	--	M81969/14-12

DMC does not provide connectors, contacts or wiring components. Parts shown here are for reference only. See disclaimer of liability on page 27.

MICRO CONNECTORS

SERIES 805 (PART 1 OF 2)



SPECIFICATIONS:
COUPLING METHOD: TRIPLE-START ACME THREAD
KEYING POSITIONS: A (NORMAL), B, C, D

MANUFACTURER:
AMPHENOL
GLENAIR

SERIES:
 2M805
 805

SHELL MATERIAL	FINISH
Aluminum	Black Anodize, Electroless Nickel, Cadmium Olive Drab Chromate, Zinc-Nickel w/ Black Chromate, Zinc-Nickel w/ Olive Drab Chromate, Nickel-PTFE
Stainless Steel	Passivated

CONTACT MILITARY PART NUMBER	CONTACT PART NUMBER	CONTACT TYPE	CONTACT SIZE	WIRE SIZE	COLOR BAND			DESCRIPTION
--	809-001*/2M809-001**	P	23	22-28	N/A	N/A	N/A	Standard Size #23 BeCu Removable Crimp Contact
--	809-042*/2M809-042**	P	23	26-30	N/A	N/A	N/A	Small Bore Size #23 BeCu Removable Crimp Contact
--	809-002*/2M809-002**	S	23	22-28	N/A	N/A	N/A	Standard Size #23 BeCu Removable Crimp Contact
--	809-043*/2M809-043**	S	23	26-30	N/A	N/A	N/A	Small Bore Size #23 BeCu Removable Crimp Contact
--	809-204*/2M809-204**	P	20HD	20-24	N/A	N/A	N/A	Size #20HD Crimp Contact
--	809-205*/2M809-205**	S	20HD	20-24	N/A	N/A	N/A	Size #20HD Crimp Contact
M39029/58-363	850-002-20-363*	P	20	20-24	Orange	Blue	Orange	Size #20 Crimp Contact
M39029/57-357	850-002-20-357*	S	20	20-24	Orange	Green	Violet	Size #20 Crimp Contact
M39029/58-364	809-110*	P	16	16-20	Orange	Blue	Yellow	Size #16 Crimp Contact
M39029/57-358	809-111*	S	16	16-20	Orange	Green	Gray	Size #16 Crimp Contact
M39029/58-365	809-112*	P	12	12-14	Orange	Blue	Green	Size #12 Crimp Contact
M39029/57-359	809-113*	S	12	12-14	Orange	Green	White	Size #12 Crimp Contact
M39029/76-424	809-114*	P	16	RG174, RG316, RG179	Yellow	Red	Yellow	Size #16 Coaxial Contact
M39029/76-425	809-115*	P	16	RG178	Yellow	Red	Green	Size #16 Coaxial Contact
M39029/78-432	809-116*	S	16	RG174, RG316, RG179	Yellow	Orange	Red	Size #16 Coaxial Contact
M39029/78-433	809-117*	S	16	RG178	Yellow	Orange	Orange	Size #16 Coaxial Contact
M39029/28-211	809-118*	P	12	RG174, RG316, RG179	Red	Brown	Brown	Size #12 Coaxial Contact
M39029/28-409	809-119*	P	12	RG180	Yellow	Black	White	Size #12 Coaxial Contact
M39029/27-210	809-120*	S	12	RG174, RG316, RG179	Red	Brown	Black	Size #12 Coaxial Contact
M39029/27-402	809-121*	S	12	RG180	Yellow	Black	Red	Size #12 Coaxial Contact
M39029/59-366	852-006-08-366*	P	8	M17/095-RG180	Orange	Blue	Blue	Size #8 Coaxial Contacts
M39029/60-367	852-007-08-367*	P	8	M17/095-RG180	Orange	Blue	Violet	Size #8 Coaxial Contacts
M39029/113-625	853-003-08-625*	P	8	M17/176-00002	Blue	Red	Green	Size #8 Concentric Twinax Contact
M39029/114-628	853-004-08-628*	S	8	M17/176-00002	Blue	Red	Violet	Size #8 Concentric Twinax Contact

*Glenair part number

**Amphenol part number

CONTACT MILITARY PART NUMBER	CONTACT PART NUMBER (GLENAIR)	CONTACT PART NUMBER (AMPHENOL)	CRIMP TOOL	PNEUMATIC TOOL	POSITIONER (GLENAIR)	POSITIONER (AMPHENOL)	CRIMP TOOL #2	DIE/ POSITIONER	INSERTION TOOL	REMOVAL TOOL
--	809-001	2M809-001	AFM8	WA22	K1461	K1461-1	--	--	809-088	809-088
--	809-042	2M809-042	AFM8	WA22	K1989	K1989-1	--	--	809-088	809-088
--	809-002	2M809-002	AFM8	WA22	K1461	K1461-1	--	--	809-088	809-088
--	809-043	2M809-043	AFM8	WA22	K1989	K1989-1	--	--	809-088	809-088
--	809-204	2M809-204	AFM8	WA22	K1859	K1859-1	--	--	809-203	809-203
--	809-205	2M809-205	AFM8	WA22	K1859	K1859-1	--	--	809-203	809-203
M39029/58-363	850-002-20-363	--	AF8	WA27F	TH163	TH163	--	--	M81969/14-10	M81969/14-10
M39029/57-357	850-002-20-357	--	AF8	WA27F	TH163	TH163	--	--	M81969/14-10	M81969/14-10
M39029/58-364	809-110	--	AF8	WA27F	TH163	TH163	--	--	M81969/14-03	M81969/14-03
M39029/57-358	809-111	--	AF8	WA27F	TH163	TH163	--	--	M81969/14-03	M81969/14-03
M39029/58-365	809-112	--	AF8	WA27F	TH163	TH163	--	--	M81969/14-04	M81969/14-04
M39029/57-359	809-113	--	AF8	WA27F	TH163	TH163	--	--	M81969/14-04	M81969/14-04
M39029/76-424	809-114	--	AFM8	WA22	K532-1	K532-1	GS100-1	GP295	DAK95-16B	DRK95-16B

DMC does not provide connectors, contacts or wiring components. Parts shown here are for reference only. See disclaimer of liability on page 27.

MICRO CONNECTORS

SERIES 805 (PART 2 OF 2)



SPECIFICATIONS:
COUPLING METHOD: TRIPLE-START ACME THREAD
KEYING POSITIONS: A (NORMAL), B, C, D

MANUFACTURER:
AMPHENOL
GLENAIR

SERIES:
 2M805
 805

SHELL MATERIAL	FINISH
Aluminum	Black Anodize, Electroless Nickel, Cadmium Olive Drab Chromate, Zinc-Nickel w/ Black Chromate, Zinc-Nickel w/ Olive Drab Chromate, Nickel-PTFE
Stainless Steel	Passivated

CONTACT MILITARY PART NUMBER	CONTACT PART NUMBER (GLENAIR)	CONTACT PART NUMBER (AMPHENOL)	CRIMP TOOL	PNEUMATIC TOOL	POSITIONER (GLENAIR)	POSITIONER (AMPHENOL)	CRIMP TOOL #2	DIE/ POSITIONER	INSERTION TOOL	REMOVAL TOOL
M39029/76-425	809-115	--	AFM8	WA22	K532-1	K532-1	GS100-1	GP295	DAK95-16B	DRK95-16B
M39029/78-432	809-116	--	AFM8	WA22	K532-1	K532-1	GS100-1	GP295	DAK95-16B	DRK95-16B
M39029/78-433	809-117	--	AFM8	WA22	K532-1	K532-1	GS100-1	GP295	DAK95-16B	DRK95-16B
M39029/28-211	809-118	--	AFM8	WA22	K323	K323	GS200-1	G2P330	DAK95-12B	DRK95-12B
M39029/28-409	809-119	--	AFM8	WA22	K323	K323	GS200-1	G2P330	DAK95-12B	DRK95-12B
M39029/27-210	809-120	--	AFM8	WA22	K323	K323	GS200-1	G2P330	DAK95-12B	DRK95-12B
M39029/27-402	809-121	--	AFM8	WA22	K323	K323	GS200-1	G2P330	DAK95-12B	DRK95-12B
M39029/59-366	852-006-08-366	--	AFM8	WA22	K406	K406	HX4	Y197	-	M81969/14-12
M39029/60-367	852-007-08-367	--	AFM8	WA22	K406	K406	HX4	Y197	-	M81969/14-12
M39029/113-625	853-003-08-625	--	AFM8	WA22	K709	K709	HX4	Y631	-	M81969/14-12
M39029/114-628	853-004-08-628	--	AFM8	WA22	K709	K709	HX4	Y631	-	M81969/14-12

DMC does not provide connectors, contacts or wiring components. Parts shown here are for reference only. See disclaimer of liability on page 27.

R.F. Connectors Tool Selection Guide

R.F. Connectors

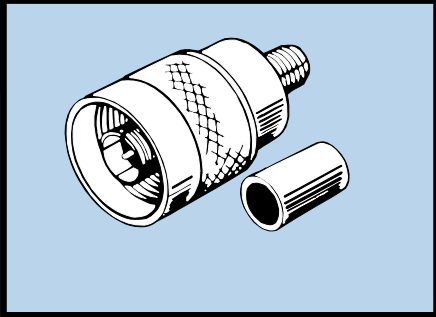

MIL-DTL-39012/1 SERIES N

CONNECTOR TYPE	CONNECTOR MILITARY PART NO.
PLUG	M39012/01-0501
	M39012/01-0502
	M39012/01-0503

CONTACT GUIDE					APPLICABLE CABLE RG-/U	M22520/1-01 CRIMP TOOL	M22520/5-01 CRIMP TOOL	POSITIONER OR DIE
CONTACT MILITARY PART NO.	I.C. OR O.F.	PIN OR	COLORBAND					
			□	○				
M39012/1-10	I.C.	P	RED	BLA	165/393	AF8		TH285
M39012/1-50	O.F.	-	-	-	393	-	HX4	Y110P & Y178 (Closure A)
M39012/1-51	O.F.	-	-	-	165	-	HX4	Y110P & Y178 (Closure A)
M39012/1-11	I.C.	P	BLU	BLA	142/400/303	-	HX4	Y110P (Closure B)
M39012/1-52	O.F.	-	-	-	142/400	-	HX4	Y197, Y205P, Y209P (Closure A) or Y142 (Closure B)
M39029/1-53	O.F.	-	-	-	303	-	HX4	Y197, Y205P, Y209P (Closure A) or Y142 (Closure B)

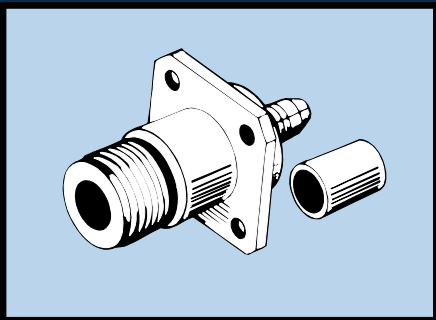

MIL-DTL-39012/2 SERIES N

CONNECTOR TYPE	CONNECTOR MILITARY PART NO.
PLUG AND RECEPTACLE FLANGE MOUNTED	M39012/02-0501
	M39012/02-0511
	M39012/02-0502
	M39012/02-0512
	M39012/02-0503
	M39012/02-0513

CONTACT GUIDE					APPLICABLE CABLE RG-/U	M22520/1-01 CRIMP TOOL	M22520/5-01 CRIMP TOOL	POSITIONER OR DIE
CONTACT MILITARY PART NO.	I.C. OR O.F.	PIN OR	COLORBAND					
			□	○				
M39012/2-10	I.C.	S	RED	BRO	393/165	AF8	-	TH285
M39012/2-50	O.F.	-	-	-	393	-	HX4	Y110P (Closure A) or Y178
M39012/2-51	O.F.	-	-	-	165	-	HX4	Y110P (Closure A) or Y178
M39012/2-11	I.C.	S	BLU	BRO	142/400/303	AF8	-	TH285
M39012/2-52	O.F.	-	-	-	142/400	-	HX4	Y197, Y205P, Y209P (Closure A) or Y142 (Closure B)
M39012/2-53	O.F.	-	-	-	303	-	HX4	Y197, Y205P, Y209P (Closure A) or Y142 (Closure B)

I.C. - Inner Contact, O.F. - Outer Ferrule

□ = Closest to Mating End ○ = Closest to Wire Entry

DMC does not provide connectors, contacts or wiring components. Parts shown here are for reference only. See disclaimer of liability on page 27.

R.F. Connectors Tool Selection Guide

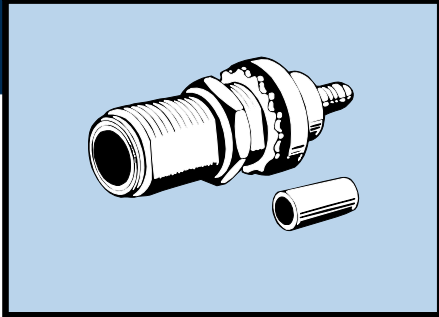

MIL-DTL-39012/3 SERIES N

CONNECTOR TYPE	CONNECTOR MILITARY PART NO.
JAM NUT MOUNTED	M39012/03-0501
	M39012/03-0502
	M39012/03-0503

CONTACT GUIDE					APPLICABLE CABLE RG-/U	M22520/1-01 CRIMP TOOL	M22520/5-01 CRIMP TOOL	POSITIONER OR DIE
CONTACT MILITARY PART NO.	I.C. OR O.F.	PIN OR	COLORBAND					
			□	○				
M39012/3-10	I.C.	S	RED	RED	165/393	AF8	-	TH286
M39012/3-50	O.F.	-	-	-	393	-	HX4	Y110P (Closure A) or Y178
M39012/3-51	O.F.	-	-	-	165	-	HX4	Y110P (Closure A) or Y178
M39012/3-11	I.C.	S	BLU	RED	142/400/303	AF8	-	TH286
M39012/3-52	O.F.	-	-	-	142/400	-	HX4	Y197, Y205P, Y209P (Closure A) or Y142 (Closure B)
M39012/3-53	O.F.	-	-	-	303	-	HX4	Y197, Y205P, Y209P (Closure A) or Y142 (Closure B)

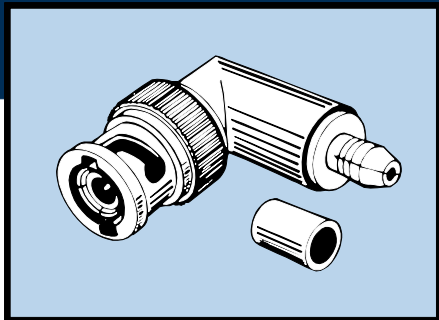

MIL-DTL-39012/5 SERIES N

CONNECTOR TYPE	CONNECTOR MILITARY PART NO.
PLUG RIGHT ANGLE	M39012/05-0501
	M39012/05-0502
	M39012/05-0503

CONTACT GUIDE					APPLICABLE CABLE RG-/U	M22520/1-01 CRIMP TOOL	M22520/5-01 CRIMP TOOL	POSITIONER OR DIE
CONTACT MILITARY PART NO.	I.C. OR O.F.	PIN OR	COLORBAND					
			□	○				
M39012/3-10	I.C.	S	RED	RED	165/393	AF8	-	TH286
M39012/3-50	O.F.	-	-	-	393	-	HX4	Y110P (Closure A) or Y178
M39012/3-51	O.F.	-	-	-	165	-	HX4	Y110P (Closure A) or Y178
M39012/3-11	I.C.	S	BLU	RED	142/400/303	AF8	-	TH286
M39012/3-52	O.F.	-	-	-	142/400	-	HX4	Y197, Y205P, Y209P (Closure A) or Y142 (Closure B)
M39012/3-53	O.F.	-	-	-	303	-	HX4	Y197, Y205P, Y209P (Closure A) or Y142 (Closure B)

I.C. - Inner Contact, O.F. - Outer Ferrule

□ = Closest to Mating End ○ = Closest to Wire Entry

DMC does not provide connectors, contacts or wiring components. Parts shown here are for reference only. See disclaimer of liability on page 27.

R.F. Connectors Tool Selection Guide

R.F. Connectors

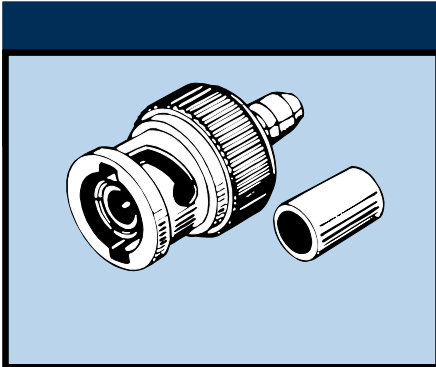

MIL-DTL-39012/16 SERIES BNC

CONNECTOR TYPE	CONNECTOR MILITARY PART NO.
PLUG	M39012/16-0501
	M39012/16-0502
	M39012/16-0503
	M39012/16-0504

CONTACT GUIDE					APPLICABLE CABLE RG-/U	M22520/1-01 CRIMP TOOL	M22520/5-01 CRIMP TOOL	POSITIONER OR DIE
CONTACT MILITARY PART NO.	I.C. OR O.F.	PIN OR	COLORBAND					
			□	○				
M39012/16-12	I.C.	P	ORA	YEL	122	AF8	-	TH270
M39012/16-50	O.F.	-	-	-	122/180	-	HX4	Y204P (Closure A) or Y197, Y140 (Closure B)
M39012/16-11	I.C.	P	BLU	YEL	180	AF8	-	TH270
M39012/16-10	I.C.	P	RED	YEL	142/400/303	AF8	-	TH270
M39012/16-51	O.F.	-	-	-	142/400	-	HX4	Y197, Y205P, Y209P (Closure A) or Y142 (Closure B)
M39012/16-52	O.F.	-	-	-	303	-	HX4	Y197, Y205P, Y209P (Closure A) or Y142 (Closure B)

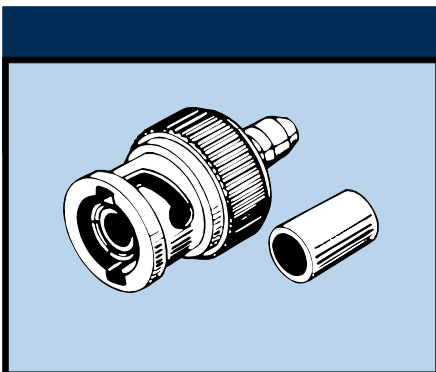

MIL-DTL-39012/17 SERIES BNC

CONNECTOR TYPE	CONNECTOR MILITARY PART NO.
PLUG	M39012/17-0501
	M39012/17-0502
	M39012/17-0503
	M39012/17-0504

CONTACT GUIDE					APPLICABLE CABLE RG-/U	M22520/1-01 CRIMP TOOL	M22520/5-01 CRIMP TOOL	POSITIONER OR DIE
CONTACT MILITARY PART NO.	I.C. OR O.F.	PIN OR	COLORBAND					
			□	○				
M39012/17-12	I.C.	S	ORA	GRE	122	AF8	-	TH270
M39012/17-50	O.F.	-	-	-	122/180	-	HX4	Y204P (Closure A) or Y197, Y140 (Closure B)
M39012/17-11	I.C.	S	BLU	GRE	180	AF8	-	TH270
M39012/17-10	I.C.	S	RED	GRE	142/400/303	AF8	-	TH270
M39012/17-51	O.F.	-	-	-	142/400	-	HX4	Y197, Y205P, Y209P (Closure A) or Y142 (Closure B)
M39012/16-52	O.F.	-	-	-	303	-	HX4	Y197, Y205P, Y209P (Closure A) or Y142 (Closure B)

I.C. - Inner Contact, O.F. - Outer Ferrule

□ = Closest to Mating End ○ = Closest to Wire Entry

DMC does not provide connectors, contacts or wiring components. Parts shown here are for reference only. See disclaimer of liability on page 27.

R.F. Connectors Tool Selection Guide

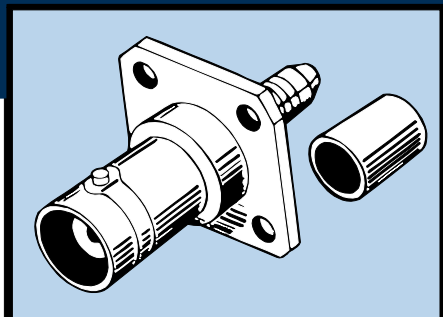

MIL-DTL-39012/18 SERIES BNC

CONNECTOR TYPE	CONNECTOR MILITARY PART NO.
RECEPTACLE, FLANGE MOUNTED	M39012/18-0501
	M39012/18-0502
	M39012/18-0503
	M39012/18-0504

CONTACT GUIDE					APPLICABLE CABLE RG-/U	M22520/1-01 CRIMP TOOL	M22520/5-01 CRIMP TOOL	POSITIONER OR DIE
CONTACT MILITARY PART NO.	I.C. OR O.F.	PIN OR	COLORBAND					
			□	○				
M39012/18-12	I.C.	S	ORA	GRE	122	AF8	-	TH270
M39012/18-50	O.F.	-	-	-	122/180	-	HX4	Y204P (Closure A) or Y197, Y140 (Closure B)
M39012/18-11	I.C.	S	BLU	GRE	180	AF8	-	TH270
M39012/18-10	I.C.	S	RED	GRE	142/400/303	AF8	-	TH270
M39012/18-51	O.F.	-	-	-	142/400	-	HX4	Y197, Y205P, Y209P (Closure A) or Y142 (Closure B)
M39012/18-52	O.F.	-	-	-	303	-	HX4	Y197, Y205P, Y209P (Closure A) or Y142 (Closure B)

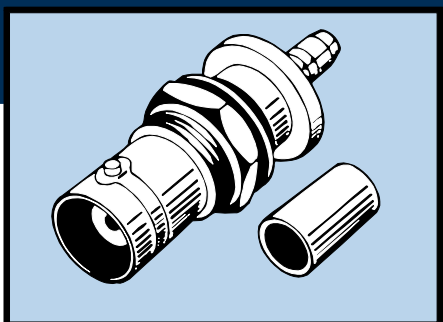

MIL-DTL-39012/19 SERIES BNC

CONNECTOR TYPE	CONNECTOR MILITARY PART NO.
JAM NUT MOUNTED	M39012/19-0501
	M39012/19-0502
	M39012/19-0503
	M39012/19-0504

CONTACT GUIDE					APPLICABLE CABLE RG-/U	M22520/1-01 CRIMP TOOL	M22520/5-01 CRIMP TOOL	POSITIONER OR DIE
CONTACT MILITARY PART NO.	I.C. OR O.F.	PIN OR	COLORBAND					
			□	○				
M39012/19-12	I.C.	S	ORA	BLU	122	AF8	-	TH270
M39012/19-11	I.C.	S	BLU	BLU	180	AF8	-	TH270
M39012/19-50	O.F.	-	-	-	180	-	HX4	Y204P (Closure A) or Y197, Y140 (Closure B)
M39012/19-10	I.C.	S	RED	BLU	142/400/303	AF8	-	TH270
M39012/19-51	O.F.	-	-	-	142/400	-	HX4	Y197, Y205P, Y209P (Closure A) or Y142 (Closure B)
M39012/19-52	O.F.	-	-	-	303	-	HX4	Y197, Y205P, Y209P (Closure A) or Y142 (Closure B)

I.C. - Inner Contact, O.F. - Outer Ferrule

□ = Closest to Mating End ○ = Closest to Wire Entry

DMC does not provide connectors, contacts or wiring components. Parts shown here are for reference only. See disclaimer of liability on page 27.

R.F. Connectors Tool Selection Guide

R.F. Connectors

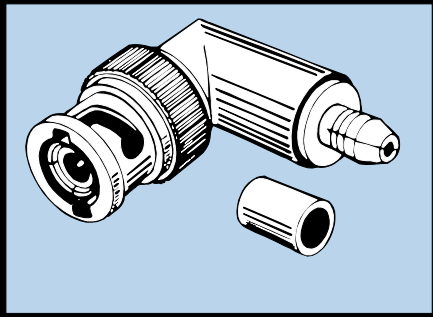

MIL-DTL-39012/20 SERIES BNC

CONNECTOR TYPE	CONNECTOR MILITARY PART NO.
PLUG RIGHT ANGLE	M39012/20-0501
	M39012/20-0502
	M39012/20-0503
	M39012/20-0504

CONTACT GUIDE					APPLICABLE CABLE RG-/U	M22520/1-01 CRIMP TOOL	M22520/5-01 CRIMP TOOL	POSITIONER OR DIE
CONTACT MILITARY PART NO.	I.C. OR O.F.	PIN OR	COLORBAND					
			□	○				
M39012/20-12	I.C.	P	ORA	VIO	122	AF8	-	TH270
M39012/20-11	I.C.	P	BLU	VIO	180	AF8	-	TH270
M39012/20-50	O.F.	-	-	-	122/180	-	HX4	Y204P (Closure A) or Y197, Y140 (Closure B)
M39012/20-10	I.C.	P	RED	VIO	142/400/303	AF8	-	TH270
M39012/20-51	O.F.	-	-	-	142/400	-	HX4	Y197, Y205P, Y209P (Closure A) or Y142 (Closure B)
M39012/20-52	O.F.	-	-	-	303	-	HX4	Y197, Y205P, Y209P (Closure A) or Y142 (Closure B)

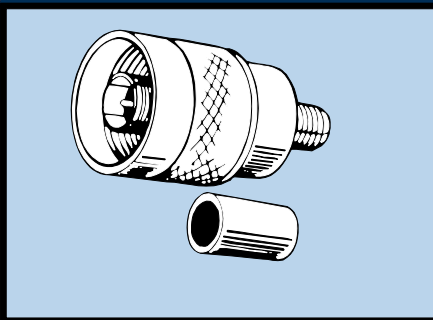

MIL-DTL-39012/26 SERIES TNC

CONNECTOR TYPE	CONNECTOR MILITARY PART NO.
PLUG PIN CONTACT	M39012/26-0501
	M39012/26-0502
	M39012/26-0503
	M39012/26-0504

CONTACT GUIDE					APPLICABLE CABLE RG-/U	M22520/1-01 CRIMP TOOL	M22520/5-01 CRIMP TOOL	POSITIONER OR DIE
CONTACT MILITARY PART NO.	I.C. OR O.F.	PIN OR	COLORBAND					
			□	○				
M39012/26-12	I.C.	P	ORN	YEL	122	AF8	-	TH270
M39012/26-11	I.C.	P	BLU	YEL	180	AF8	-	TH270
M39012/26-50	O.F.	-	-	-	180/122	-	HX4	Y204P (Closure A) or Y197, Y140 (Closure B)
M39012/26-10	I.C.	P	RED	YEL	142/400/303	AF8	-	TH270
M39012/26-51	O.F.	-	-	-	142/400	-	HX4	Y197, Y205P, Y209P (Closure A) or Y142 (Closure B)
M39012/26-52	O.F.	-	-	-	303	-	HX4	Y197, Y205P, Y209P (Closure A) or Y142 (Closure B)

I.C. - Inner Contact, O.F. - Outer Ferrule

□ = Closest to Mating End ○ = Closest to Wire Entry

DMC does not provide connectors, contacts or wiring components. Parts shown here are for reference only. See disclaimer of liability on page 27.

R.F. Connectors Tool Selection Guide

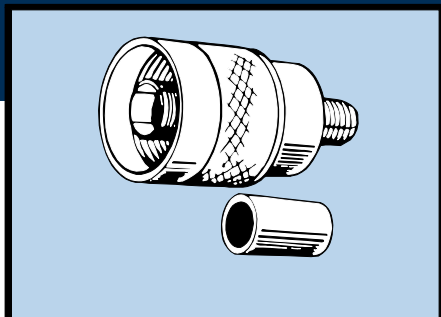

MIL-DTL-39012/27 SERIES TNC

CONNECTOR TYPE	CONNECTOR MILITARY PART NO.
PLUG	M39012/27-0501
	M39012/27-0502
	M39012/27-0503
	M39012/27-0504

CONTACT GUIDE					APPLICABLE CABLE RG-/U	M22520/1-01 CRIMP TOOL	M22520/5-01 CRIMP TOOL	POSITIONER OR DIE
CONTACT MILITARY PART NO.	I.C. OR O.F.	PIN OR	COLORBAND					
			□	○				
M39012/27-12	I.C.	S	ORN	GRE	122	AF8	-	TH270
M39012/27-11	I.C.	S	BLU	GRE	180	AF8	-	TH270
M39012/27-50	O.F.	-	-	-	180/122	-	HX4	Y204P (Closure A) or Y197, Y140 (Closure B)
M39012/27-10	I.C.	S	RED	GRE	142/303	AF8	-	TH270
M39012/27-51	O.F.	-	-	-	142	-	HX4	Y197, Y205P, Y209P (Closure A) or Y142 (Closure B)
M39012/27-52	O.F.	-	-	-	303	-	HX4	Y197, Y205P, Y209P (Closure A) or Y142 (Closure B)

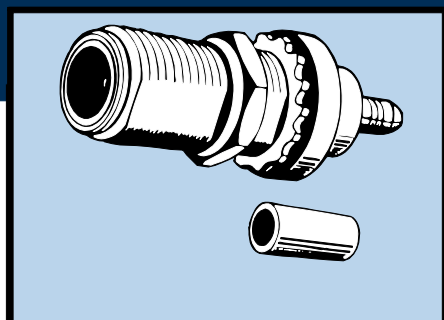

MIL-DTL-39012/28 SERIES TNC

CONNECTOR TYPE	CONNECTOR MILITARY PART NO.
JAM NUT MOUNTED	M39012/28-0501
	M39012/28-0502
	M39012/28-0503
	M39012/28-0504

CONTACT GUIDE					APPLICABLE CABLE RG-/U	M22520/1-01 CRIMP TOOL	M22520/5-01 CRIMP TOOL	POSITIONER OR DIE
CONTACT MILITARY PART NO.	I.C. OR O.F.	PIN OR	COLORBAND					
			□	○				
M39012/28-12	I.C.	S	ORN	BLU	122	AF8	-	TH270
M39012/28-11	I.C.	S	BLU	BLU	180	AF8	-	TH270
M39012/28-50	O.F.	-	-	-	122/180	-	HX4	Y204P (Closure A) or Y197, Y140 (Closure B)
M39012/28-10	I.C.	S	RED	BLU	142/303	AF8	-	TH270
M39012/28-51	O.F.	-	-	-	142	-	HX4	Y197, Y205P, Y209P (Closure A) or Y142 (Closure B)
M39012/28-52	O.F.	-	-	-	303	-	HX4	Y197, Y205P, Y209P (Closure A) or Y142 (Closure B)

I.C. - Inner Contact, O.F. - Outer Ferrule

□ = Closest to Mating End ○ = Closest to Wire Entry

DMC does not provide connectors, contacts or wiring components. Parts shown here are for reference only. See disclaimer of liability on page 27.

R.F. Connectors Tool Selection Guide

R.F. Connectors

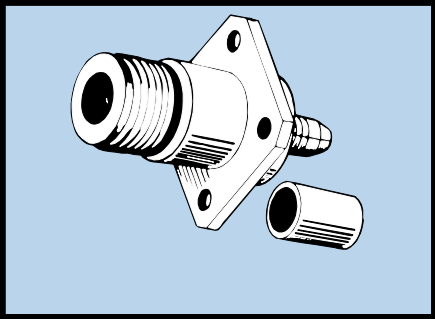

MIL-DTL-39012/29 SERIES TNC

CONNECTOR TYPE	CONNECTOR MILITARY PART NO.
RECEPTACLE FLANGE MOUNTED	M39012/29-0501
	M39012/29-0502
	M39012/29-0503
	M39012/29-0504

CONTACT GUIDE					APPLICABLE CABLE RG-/U	M22520/1-01 CRIMP TOOL	M22520/5-01 CRIMP TOOL	POSITIONER OR DIE
CONTACT MILITARY PART NO.	I.C. OR O.F.	PIN OR	COLORBAND					
			□	○				
M39012/29-12	I.C.	S	ORN	GRE	122	AF8	-	TH270
M39012/29-11	I.C.	S	BLU	GRE	180	AF8	-	TH270
M39012/29-50	O.F.	-	-	-	122/180	-	HX4	Y204P (Closure A) or Y197, Y140 (Closure B)
M39012/29-10	I.C.	S	RED	GRE	142/303	AF8	-	TH270
M39012/29-51	O.F.	-	-	-	142	-	HX4	Y197, Y205P, Y209P (Closure A) or Y142 (Closure B)
M39012/29-52	O.F.	-	-	-	303	-	HX4	Y197, Y205P, Y209P (Closure A) or Y142 (Closure B)

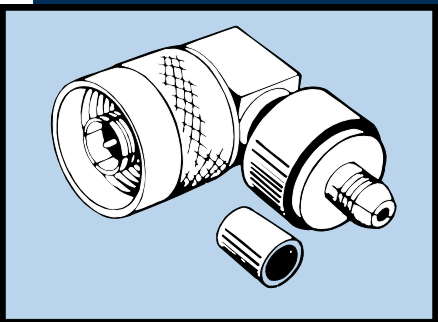

MIL-DTL-39012/30 SERIES TNC

CONNECTOR TYPE	CONNECTOR MILITARY PART NO.
PLUG RIGHT ANGLE	M39012/30-0501
	M39012/30-0502
	M39012/30-0503
	M39012/30-0504

CONTACT GUIDE					APPLICABLE CABLE RG-/U	M22520/1-01 CRIMP TOOL	M22520/5-01 CRIMP TOOL	POSITIONER OR DIE
CONTACT MILITARY PART NO.	I.C. OR O.F.	PIN OR	COLORBAND					
			□	○				
M39012/29-12	I.C.	S	ORN	GRE	122	AF8	-	TH270
M39012/29-11	I.C.	S	BLU	GRE	180	AF8	-	TH270
M39012/29-50	O.F.	-	-	-	122/180	-	HX4	Y204P (Closure A) or Y197, Y140 (Closure B)
M39012/29-10	I.C.	S	RED	GRE	142/303	AF8	-	TH270
M39012/29-51	O.F.	-	-	-	142	-	HX4	Y197, Y205P, Y209P (Closure A) or Y142 (Closure B)
M39012/29-52	O.F.	-	-	-	303	-	HX4	Y197, Y205P, Y209P (Closure A) or Y142 (Closure B)

I.C. - Inner Contact, O.F. - Outer Ferrule

□ = Closest to Mating End ○ = Closest to Wire Entry

DMC does not provide connectors, contacts or wiring components. Parts shown here are for reference only. See disclaimer of liability on page 27.

R.F. Connectors Tool Selection Guide

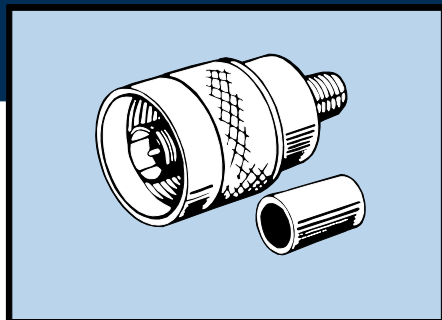

MIL-DTL-39012/35 SERIES SC

CONNECTOR TYPE	CONNECTOR MILITARY PART NO.
PLUG PIN CONTACT	M39012/35-0501
	M39012/35-0502
	M39012/35-0503

CONTACT GUIDE					APPLICABLE CABLE RG-/U	M22520/1-01 CRIMP TOOL	M22520/5-01 CRIMP TOOL	POSITIONER OR DIE
CONTACT MILITARY PART NO.	I.C. OR O.F.	PIN OR	COLORBAND					
			□	○				
M39012/35-10	I.C.	P	RED	GRA	214/225/393	AF8	-	TH286
M39012/35-50	O.F.	-	-	-	214/225/393	-	HX4	Y110P (Closure A)
M39012/35-11	I.C.	P	BLU	GRA	213	AF8	-	TH286
M39012/35-51	O.F.	-	-	-	213	-	HX4	Y197, Y205P, Y209P (Closure A) or Y142 (Closure B)
M39012/35-52	O.F.	-	-	-	142/400	-	HX4	Y197, Y205P, Y209P (Closure A) or Y142 (Closure B)

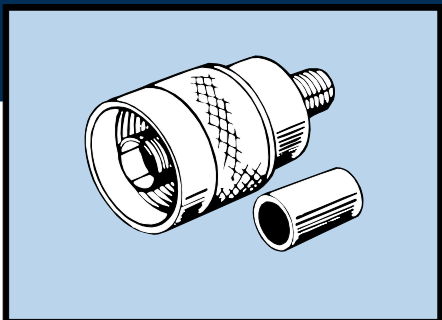

MIL-DTL-39012/36 SERIES SC

CONNECTOR TYPE	CONNECTOR MILITARY PART NO.
PLUG	M39012/36-0501
	M39012/36-0502
	M39012/36-0503

CONTACT GUIDE					APPLICABLE CABLE RG-/U	M22520/1-01 CRIMP TOOL	M22520/5-01 CRIMP TOOL	POSITIONER OR DIE
CONTACT MILITARY PART NO.	I.C. OR O.F.	PIN OR	COLORBAND					
			□	○				
M39012/36-10	I.C.	S	RED	WHI	214/225/393	AF8	-	TH286
M39012/36-50	O.F.	-	-	-	214/225/393	-	HX4	Y110P (Closure A) or Y178
M39012/36-51	O.F.	-	-	-	213	-	HX4	Y110P (Closure A) or Y178
M39012/36-11	I.C.	S	BLU	WHI	142/400	AF8	-	TH286
M39012/36-52	O.F.	-	-	-	142/400	-	HX4	Y197, Y205P, Y209P (Closure A) or Y142 (Closure B)

I.C. - Inner Contact, O.F. - Outer Ferrule

□ = Closest to Mating End ○ = Closest to Wire Entry

DMC does not provide connectors, contacts or wiring components. Parts shown here are for reference only. See disclaimer of liability on page 27.

R.F. Connectors Tool Selection Guide

R.F. Connectors

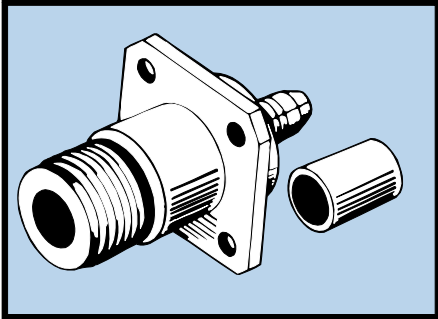

MIL-DTL-39012/38 SERIES SC

CONNECTOR TYPE	CONNECTOR MILITARY PART NO.
RECEPTACLE FLANGE MOUNTED	M39012/38-0501
	M39012/38-0502
	M39012/38-0503

CONTACT GUIDE					APPLICABLE CABLE RG-/U	M22520/1-01 CRIMP TOOL	M22520/5-01 CRIMP TOOL	POSITIONER OR DIE
CONTACT MILITARY PART NO.	I.C. OR O.F.	PIN OR	COLORBAND					
			□	○				
M39012/38-10	I.C.	P	RED	WHI	165/393	AF8	-	TH286
M39012/38-50	O.F.	-	-	-	393	-	HX4	Y110P (Closure A) or Y178
M39012/38-51	O.F.	-	-	-	165	-	HX4	Y110P (Closure A) or Y178
M39012/38-11	I.C.	P	BLU	WHI	142/400	AF8	-	TH286
M39012/38-52	O.F.	-	-	-	142/400	-	HX4	Y197, Y205P, Y209P (Closure A) or Y142 (Closure B)

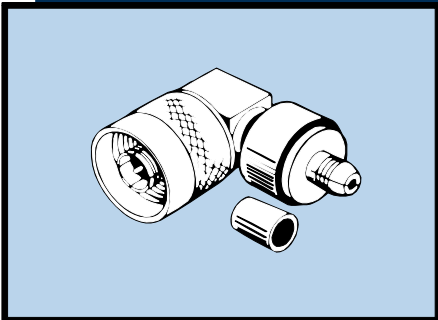

MIL-DTL-39012/39 SERIES SC

CONNECTOR TYPE	CONNECTOR MILITARY PART NO.
PLUG RIGHT ANGLE	M39012/39-0501
	M39012/39-0502
	M39012/39-0503

CONTACT GUIDE					APPLICABLE CABLE RG-/U	M22520/1-01 CRIMP TOOL	M22520/5-01 CRIMP TOOL	POSITIONER OR DIE
CONTACT MILITARY PART NO.	I.C. OR O.F.	PIN OR	COLORBAND					
			□	○				
M39012/39-10	I.C.	P	RED	ORN	214/393/165/213	AF8	-	TH285
M39012/39-50	O.F.	-	-	-	214/393	-	HX4	Y110P (Closure A) or Y178
M39012/39-51	O.F.	-	-	-	165/213	-	HX4	Y110P (Closure A) or Y178
M39012/39-11	I.C.	P	BLU	ORN	142/223/400	AF8	-	TH285
M39012/39-52	O.F.	-	-	-	142/223/400	-	HX4	Y197, Y205P, Y209P (Closure A) or Y142 (Closure B)

I.C. - Inner Contact, O.F. - Outer Ferrule

□ = Closest to Mating End ○ = Closest to Wire Entry

DMC does not provide connectors, contacts or wiring components. Parts shown here are for reference only. See disclaimer of liability on page 27.

R.F. Connectors Tool Selection Guide

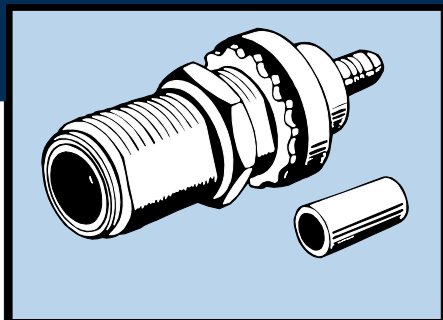

MIL-DTL-39012/40 SERIES SC

CONNECTOR TYPE	CONNECTOR MILITARY PART NO.
JAM NUT MOUNTED	M39012/40-0501
	M39012/40-0502
	M30912/40-0503

CONTACT GUIDE					APPLICABLE CABLE RG-/U	M22520/1-01 CRIMP TOOL	M22520/5-01 CRIMP TOOL	POSITIONER OR DIE
CONTACT MILITARY PART NO.	I.C. OR O.F.	PIN OR	COLORBAND					
			□	○				
M39012/40-10	I.C.	S	RED	GLD	165/393	AF8	-	TH286
M39012/40-50	O.F.	-	-	-	393	-	HX4	Y110P (Closure A) or Y178
M39012/40-51	O.F.	-	-	-	165	-	HX4	Y110P (Closure A) or Y178
M39012/40-11	I.C.	S	BLU	GLD	142/400	AF8	-	TH286
M39012/40-52	O.F.	-	-	-	142/400	-	HX4	Y197, Y205P, Y209P (Closure A) or Y142 (Closure B)

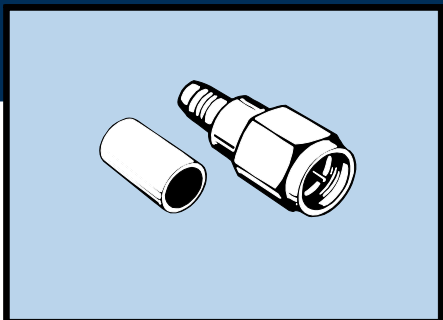

MIL-DTL-39012/55 SERIES SMA

CONNECTOR TYPE	CONNECTOR MILITARY PART NO.
PLUG PIN CONTACT	M39012/55-3502
	M39012/55-4502

CONTACT GUIDE					APPLICABLE CABLE RG-/U	M22520/1-01 CRIMP TOOL	M22520/5-01 CRIMP TOOL	POSITIONER OR DIE
CONTACT MILITARY PART NO.	I.C. OR O.F.	PIN OR	COLORBAND					
			□	○				
M39012/55-10	I.C.	P	RED	SIL	142/400	AF8	-	TP485
M39012/55-50	O.F.	-	-	-	142/400	-	HX4	Y197, Y205P, Y209P (Closure A) or Y142 (Closure B)

I.C. - Inner Contact, O.F. - Outer Ferrule

□ = Closest to Mating End ○ = Closest to Wire Entry

DMC does not provide connectors, contacts or wiring components. Parts shown here are for reference only. See disclaimer of liability on page 27.

R.F. Connectors Tool Selection Guide

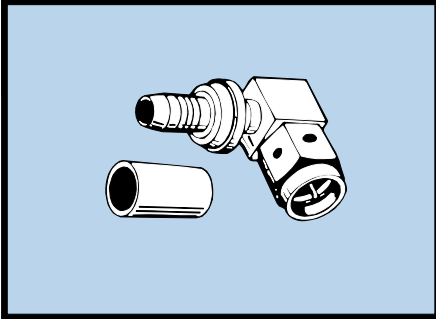

MIL-DTL-39012/56 SERIES SMA

CONNECTOR TYPE	CONNECTOR MILITARY PART NO.
PLUG RIGHT ANGLE	M39012/56-3502
	M39012/56-4502

CONTACT GUIDE					APPLICABLE CABLE RG-/U	M22520/1-01 CRIMP TOOL	M22520/5-01 CRIMP TOOL	POSITIONER OR DIE
CONTACT MILITARY PART NO.	I.C. OR O.F.	PIN OR	COLORBAND					
			□	○				
M39012/56-10	I.C.	P	RED	MRN	142/400	AF8	-	TP485
M39012/56-50	O.F.	-	-	-	142/400	-	HX4	Y197, Y205P, Y209P (Closure A) or Y142 (Closure B)

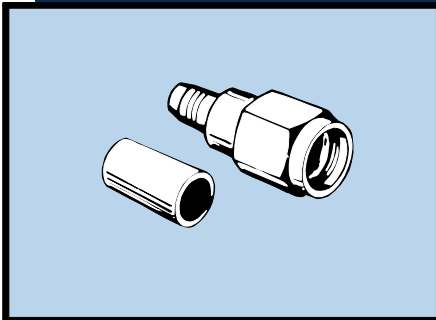

MIL-DTL-39012/57 SERIES SMA

CONNECTOR TYPE	CONNECTOR MILITARY PART NO.
PLUG SOCKET CONTACT	M39012/57-3502
	M39012/57-4502

CONTACT GUIDE					APPLICABLE CABLE RG-/U	M22520/1-01 CRIMP TOOL	M22520/5-01 CRIMP TOOL	POSITIONER OR DIE
CONTACT MILITARY PART NO.	I.C. OR O.F.	PIN OR	COLORBAND					
			□	○				
M39012/57-10	I.C.	S	RED	MRN	142/400	AF8	-	TP485
M39012/57-50	O.F.	-	-	-	142/400	-	HX4	Y197, Y205P, Y209P (Closure A) or Y142 (Closure B)

I.C. - Inner Contact, O.F. - Outer Ferrule

□ = Closest to Mating End ○ = Closest to Wire Entry

DMC does not provide connectors, contacts or wiring components. Parts shown here are for reference only. See disclaimer of liability on page 27.

R.F. Connectors Tool Selection Guide

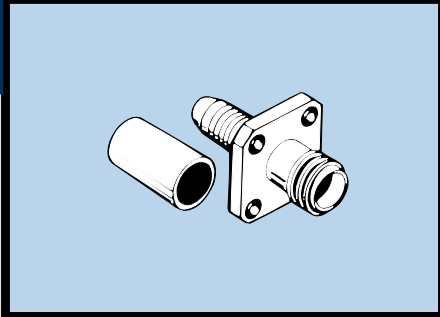

MIL-DTL-39012/58 SERIES SMA

CONNECTOR TYPE	CONNECTOR MILITARY PART NO.
RECEPTACLE FLANGE MOUNTED	M39012/58-3502
	M39012/58-4502

CONTACT GUIDE					APPLICABLE CABLE RG-/U	M22520/1-01 CRIMP TOOL	M22520/5-01 CRIMP TOOL	POSITIONER OR DIE
CONTACT MILITARY PART NO.	I.C. OR O.F.	PIN OR	COLORBAND					
			□	○				
M39012/58-10	I.C.	S	RED	MRN	142/400	AF8	-	TP485
M39012/58-50	O.F.	-	-	-	142/400	-	HX4	Y197, Y205P, Y209P (Closure A) or Y142 (Closure B)

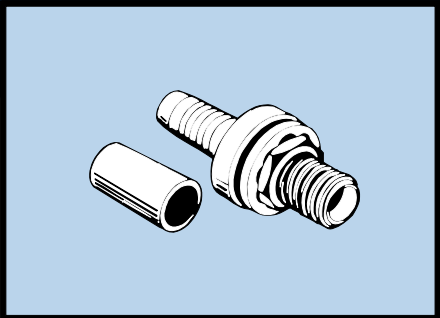

MIL-DTL-39012/59 SERIES SMA

CONNECTOR TYPE	CONNECTOR MILITARY PART NO.
JAM NUT MOUNTED	M39012/59-3502
	M39012/59-4502

CONTACT GUIDE					APPLICABLE CABLE RG-/U	M22520/1-01 CRIMP TOOL	M22520/5-01 CRIMP TOOL	POSITIONER OR DIE
CONTACT MILITARY PART NO.	I.C. OR O.F.	PIN OR	COLORBAND					
			□	○				
M39012/59-10	I.C.	S	RED	MRN	142/400	AF8	-	TP485
M39012/59-50	O.F.	-	-	-	142/400	-	HX4	Y197, Y205P, Y209P (Closure A) or Y142 (Closure B)

I.C. - Inner Contact, O.F. - Outer Ferrule

□ = Closest to Mating End ○ = Closest to Wire Entry

DMC does not provide connectors, contacts or wiring components. Parts shown here are for reference only. See disclaimer of liability on page 27.

M39029 Coaxial/Shielded Contact (Connector Series) Tool Selection Guide

CONTACT		INNER		OUTER		ASSEMBLY TOOLS	
BIN CODE	CAVITY SIZE	CRIMPING TOOL	POSITIONER	CRIMPING TOOL	POSITIONER OR DIE	INSTALLING TOOL	REMOVAL TOOL
M39029/6 PIN CONTACT (SAE AS81511 Series 1 & 2) CANCELED							
M39029/7 PIN CONTACT (MIL-DTL-26482 Series 2 & MIL-DTL-81703 Series 3)							
126	12	AFM8	K269-1	HX4	Y203	DAK83-12B	DRK83-12B
127	12	AFM8	K269-1	HX4	Y203	DAK83-12B	DRK83-12B
128	12	AFM8	K269-1	HX4	Y203	DAK83-12B	DRK83-12B
M39029/8 SOCKET CONTACT (MIL-DTL-26482 Series 2 & MIL-DTL-81703 Series 3)							
129	12	AFM8	K269-1	HX4	Y203	DAK83-12B	DRK83-12B
130	12	AFM8	K269-1	HX4	Y203	DAK83-12B	DRK83-12B
131	12	AFM8	K269-1	HX4	Y203	DAK83-12B	DRK83-12B
M39029/13 SOCKET CONTACT (SAE AS81511 Series 1) CANCELED							
M39029/14 SOCKET CONTACT (SAE AS81511 Series 2) CANCELED							
M39029/19 PIN CONTACT (SAE AS81511 Series 3 & 4)							
181	16	AFM8	K373-1	MH801	D16P-1M	M81969/16-02	M81969/16-02
		AFM8	K373-1	MH801	D16P-1M		
182	12	AFM8	K372-1	MH803	D12P-1M	M81969/16-03	M81969/16-03
		AFM8	K372-1	MH803	D12P-1M		
183	12	AFM8	K373-1	MH803	D12P-1M	M81969/16-03	M81969/16-03
		AFM8	K373-1	MH803	D12P-1M		
		AFM8	K372-1	MH803	D12P-1M		
		AFM8	K372-1	MH803	D12P-1M		
M39029/20 SOCKET CONTACT (SAE AS81511 Series 3)							
184	16	AFM8	K373-1	MH801	D16LS-1M	M81969/16-02	M81969/16-02
		AFM8	K373-1	MH801	D16LS-1M		
185	12	AFM8	K372-1	MH803	D12LS-1M	M81969/16-03	M81969/16-03
		AFM8	K372-1	MH803	D12LS-1M		
186	12	AFM8	K372-1	MH803	D12LS-1M	M81969/16-03	M81969/16-03
		AFM8	K372-1	MH803	D12LS-1M		
		AFM8	K372-1	MH803	D12LS-1M		
		AFM8	K372-1	MH803	D12LS-1M		
M39029/21 SOCKET CONTACT (SAE AS81511 Series 4)							
187	16	AFM8	K373-1	MH801	D16S-1M	M81969/16-02	M81969/16-02
		AFM8	K373-1	MH801	D16S-1M		
188	12	AFM8	K372-1	MH803	D12S-1M	M81969/16-03	M81969/16-03
		AFM8	K372-1	MH803	D12S-1M		
189	12	AFM8	K372-1	MH801	D16S-1M	M81969/16-03	M81969/16-03
		AFM8	K372-1	MH801	D16S-1M		
		AFM8	K372-1	MH803	D12S-1M		
		AFM8	K372-1	MH803	D12S-1M		
M39029/25-PIN CONTACT (MIL-DTL-26482 Series 1)							
204	12	AFM8	K496	HX4	Y189	DAK12B	DRK12B
205	12	AFM8	K496	None	None		
206	12	AFM8	K496	HX4	Y189		

DMC does not provide connectors, contacts or wiring components. Parts shown here are for reference only. See disclaimer of liability on page 27.

Coaxial/Shielded Contact Tool Selection Guide

CONTACT		INNER		OUTER		ASSEMBLY TOOLS	
BIN CODE	CAVITY SIZE	CRIMPING TOOL	POSITIONER	CRIMPING TOOL	POSITIONER OR DIE	INSTALLING TOOL	REMOVAL TOOL
M39029/26 SOCKET CONTACT (MIL-DTL-26482 Series 1)							
207	12	AFM8	K323	HX4	Y189	DAK12B	DRK12B
208	12	AFM8	K323	None	None		
209	12	AFM8	K323	HX4	Y189		
M39029/27 SOCKET CONTACT (MIL-DTL-38999 Series 2)							
210	12	AFM8	K323	GS200-1	G2P330	DAK95-12B	DRK95-12B
402	12	AFM8	K323	GS200-1	G2P330	DAK95-12B	DRK95-12B
403	12						
404	12						
405	12						
406	12						
407	12						
408	12						
M39029/28 PIN CONTACT (MIL-DTL-38999 Series 1, 2, 3 & 4)							
211	12	AFM8	K323	GS200-1	G2P330	DAK95-12B	DRK95-12B
409	12	AFM8	K323	GS200-1	G2P330	DAK95-12B	DRK95-12B
410	12						
411	12						
412	12						
413	12						
414	12						
415	12						
M39029/50 SOCKET CONTACT (MIL-DTL-83733)							
340	12	AFM8	K404	HX4	Y215	DAK83-12B	DRK83-12B
				HX3	X101		
M39029/51 SOCKET CONTACT (MIL-DTL-83733)							
341	12	AFM8	K404	HX4	Y215	DAK83-12B	DRK83-12B
				HX3	X101		
M39029/54 PIN CONTACT (MIL-DTL-26500 and MIL-DTL-26518)							
342	12	AFM8	K404	HX4	Y215	DAK-12B	DRK12B
				HX3	X101		
343	8	AFM8	K75S	HX4	Y189	DAK55-8B	DRK56-8B
				HX3	X125		
M39029/55 SOCKET CONTACT (MIL-DTL-26500 and MIL-DTL-26518)							
344	12	AFM8	K745	HX4	Y215	DAK12B	DRK12B
				HX3	X101		
345	12	AFM8	K75S-1	HX4	Y189	DAK12B	DRK12B
				HX3	X125		

DMC does not provide connectors, contacts or wiring components. Parts shown here are for reference only. See disclaimer of liability on page 27.

Coaxial/Shielded Contact Tool Selection Guide

CONTACT		INNER		OUTER		ASSEMBLY TOOLS	
BIN CODE	CAVITY SIZE	CRIMPING TOOL	POSITIONER	CRIMPING TOOL	POSITIONER OR DIE	INSTALLING TOOL	REMOVAL TOOL
M39029/59 Socket CONTACT (MIL-DTL-24308)							
366	8	AFM8	K406	HX4	Y197	DAK95-8B	DRK95-8B
				HX3	X102		
M39029/60 PIN CONTACT (MIL-DTL-38999 Series 1, 3, & 4)							
367	8	AFM8	K406	HX4	Y197	DAK95-8B	DRK95-8B
				HX3	X102		
M39029/75 SOCKET CONTACT (MIL-DTL-38999 Series 1, 3, & 4)							
416	12	AFM8	K323	GS200-1	G2P330	DAK95-12B	DRK95-12B
417							
418							
419							
420							
421							
422							
423							
M39029/76 PIN CONTACT (MIL-DTL-38999 Series 1, 2, 3 & 4)							
424	16	AFM8	K532-1	GS100-1	GP295	DAK95-16B	DRK95-16B
425							
426							
427							
M39029/77 SOCKET CONTACT (MIL-DTL- 38999 Series 1, 3, & 4)							
428	16	AFM8	K532-1	GS100-1	GP295	DAK95-16B	DRK95-16B
429							
430							
431							
M39029/78 SOCKET CONTACT (MIL-DTL-38999 Series 2 & MIL-DTL-24308)							
432	16	AFM8	K532-1	GS100-1	GP295	DAK95-16B	DRK95-16B
433							
434							
435							
M39029/79 PIN CONTACT (MIL-DTL-28748/9)							
436	16	HX3-530	N/A	HX3-530	N/A	DAK16B	DRK597
437	16	HX3-530	N/A	HX3-530	N/A	DAK16B	DRK597
M39029/80 SOCKET CONTACT (MIL-DTL-28748/10)							
438	16	HX3-530	N/A	HX3-530	N/A	DAK16B	DRK597
439	16	HX3-530	N/A	HX3-530	N/A	DAK16B	DRK597
M39029/102 PIN CONTACT (MIL-DTL-38999 Series 1, 3 & 4)							
558	12	MH992 (TE/DEUTCH) AFM8 (TRISTAR) MH992(AMPHENOL)	K1303S K1430 K1360	HX4	Y196 (A)	DAK95-12B	DRK95-12B
M39029/103 SOCKET CONTACT (MIL-DTL-38999 Series 1, 3 & 4)							
559	12	MH992 (TE/DEUTCH) AFM8 (TRISTAR) MH992(AMPHENOL)	K1304 K1453 K1360	HX4	Y196 (A)	DAK95-12B	DRK95-12B

DMC does not provide connectors, contacts or wiring components. Parts shown here are for reference only. See disclaimer of liability on page 27.

Y-Dies For A Full Range of Capabilities

DMC constantly adds new crimp die designs that are comparable to connector and terminal supplier dies or tools. A few of the popular “Y” die applications are featured in the following chart. For more options, contact DMC.

TYPICAL DIE CONFIGURATIONS

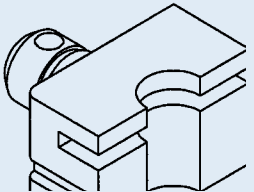
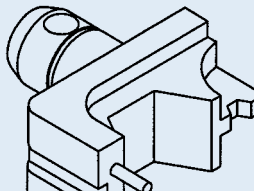
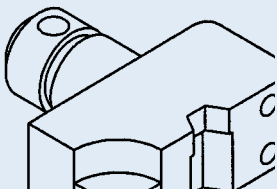
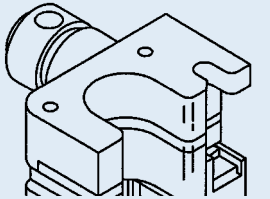
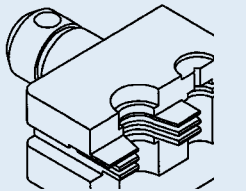
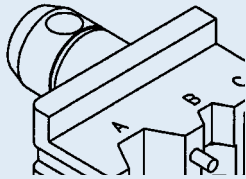

MFR. TOOL	DMC	MFR. TOOL	DMC	MFR. TOOL	DMC	MFR. TOOL	DMC
TE (AMP) 220009-1-B	Y827	TE (AMP) 9036402A	Y929	IT CANNON 995-0002-228	Y793	MS25312-1	Y510
TE (AMP) 220015-1	Y587	AMPHENOL 227-1221-6001	Y951	IT CANNON APK 15 & 25	Y831	MS25312-2	Y509
TE (AMP) 220045-2	Y588	AMPHENOL 227-1228	Y240S	IT CANNON BUCH. 612992	Y331	MS25312-3	Y508
TE (AMP) 220066-1	Y586	AMPHENOL 227-1242	Y323S	IT CANNON CCT-406M	Y321	MS25312-4	Y507
TE (AMP) 227-1400	Y800P	AMPHENOL 227-125	Y129	IT CANNON CCT-C1	Y316	MS27143	Y627
TE (AMP) 277-980-3	Y773P	AMPHENOL 227-1350	Y324S	IT CANNON CCT-C10	Y320	MS27144	Y627
TE (AMP) 45158-2	Y717	AMPHENOL 227-1351-1	Y325	IT CANNON CCT-C2	Y555	MS27148	Y627
TE (AMP) 45238-2	Y721	AMPHENOL 227-1351-2	Y344	IT CANNON CCT-C3	Y317	RADIALL R282 235 901	Y915
TE (AMP) 45239-2	Y720	AMPHENOL 227-1351-3	Y326	IT CANNON CCT-C5	Y318	RADIALL R282230	Y342
TE (AMP) 45240-2	Y719	AMPHENOL 227-1351-4	Y346	IT CANNON CCT-C6	Y319	TE (RAYCHEM) AD1377	Y516
TE (AMP) 45241-2	Y718	AMPHENOL 227-1351-5	Y347	IT CANNON CCT-C7A	Y557	T&B WT232	Y173
TE (AMP) 46673	Y751A	AMPHENOL 227-1351-6	Y348	IT CANNON CCT-C8	Y558	T&B RA18-188	Y580
TE (AMP) 46673-1	Y751B	AMPHENOL 227-1354	Y355S	IT CANNON CCT-C9	Y559	T&B WT157N	Y689
TE (AMP) 46988	Y752	AMPHENOL 227-1355	Y356S	IT CANNON CCT-CKM1	Y560	T&B WT200	Y119
TE (AMP) 49935	Y788	AMPHENOL 227-1358	Y357	IT CANNON CCT-CX2	Y556	T&B WT200-06-08	Y360
TE (AMP) 501295-1	Y923	AMPHENOL 227-1392-03	Y488S	IT CANNON CCT-DM	Y322	T&B WT200-06-11	Y443
TE (AMP) 52561	Y934A	AMPHENOL 227-1395	Y654	DEUTSCH 20055	Y380	T&B WT201-03-10	Y410
TE (AMP) 58237-1	Y902	AMPHENOL 227-1402	Y677	KINGS /0-3	Y397	T&B WT202-06-08	Y409
TE (AMP) 58237-2	Y897	AMPHENOL 227-1403	Y493	KINGS 683-51559	Y467	T&B WT202-06-08	Y411
TE (AMP) 58238-2-A	Y896	AMPHENOL 227-1409	Y688PS	KINGS 1002	Y464	T&B WT203	Y198
TE (AMP) 58249-1	Y692	AMPHENOL 227-1414	Y780	KINGS 1061	Y575	T&B WT209, 409	Y211
TE (AMP) 543424-2	Y906	AMPHENOL 227-200	Y133	KINGS 1077	Y828P	T&B WT210, 410	Y212
TE (AMP) 543424-7	Y904	AMPHENOL 227-350	Y132	KINGS 1078	Y609	T&B WT215	Y139
TE (AMP) 543424-5	Y903	AMPHENOL 227-375	Y131	KINGS 1079	Y630P	T&B WT216	Y138
TE (AMP) 543424-6	Y905	AMPHENOL 227-400	Y130P	KINGS 2002	Y269	T&B WT218	Y145
TE (AMP) 58423-1	Y810P	AMPHENOL 227-425	Y134	KINGS 2012	Y277	T&B WT226	Y169
TE (AMP) 58423-2	Y811P	AMPHENOL 227-600	Y225	KINGS 2021	Y339	T&B WT227	Y170
TE (AMP) 59215	Y619	AMPHENOL 227-911	Y442	KINGS 2024	Y423	T&B WT229	Y178P
TE (AMP) 59250	Y1060	AMPHENOL 227-911	Y623	KINGS 2042	Y209P	T&B WT230	Y179
TE (AMP) 59275	Y1061	AMPHENOL 227-980-1	Y685	KINGS 2061	Y572	T&B WT231	Y180
TE (AMP) 59255	Y753	AMPHENOL 227-980-2	Y686	KINGS 2062	K575	T&B WT233	Y242
TE (AMP) 59459	Y745	AMPHENOL 227-980-5	Y787P	KINGS 2062	Y762P	T&B WT234	Y293
TE (AMP) 59461	Y794	AMPHENOL 294-1832	Y200P	KINGS 2063	Y617	T&B WT235	Y246
TE (AMP) 59493-1	Y843	AMPHENOL 294-532	Y200P	KINGS 2064	Y574	T&B WT238	Y245
TE (AMP) 59508	Y748	AMPHENOL 294GB-5031	Y731	KINGS 2067	Y573	T&B WT311	Y243
TE (AMP) 59962-1	Y1997	AMPHENOL 48-326	Y477	KINGS 2067	Y760P	T&B WT400	Y203
TE (AMP) 69149-1	Y732	AMPHENOL 611X1151	Y336	KINGS 2081	Y613	T&B WT400	Y215
TE (AMP) 69223-1	Y733	AMPHENOL 611X1275-1	Y564	KINGS 2082	Y600	T&B WT400-02-08	Y219
TE (AMP) 69224-1	Y734	AMPHENOL 790-5185	Y255S	KINGS 2101	Y633	T&B WT401	Y201
TE (AMP) 69266-1	Y735	AMPHENOL 790-5284	Y257	KINGS 2103	Y680	T&B WT401, 406, 411	Y292
TE (AMP) 69339	Y589	AMPHENOL 790-5285	Y254	KINGS 2105	Y634	T&B WT402	Y214
TE (AMP) 69352	Y749	AMPHENOL 790-5431	Y250	KINGS 2127	Y635	T&B WT406	Y216
TE (AMP) 69355	Y750	ASTRO. 613876	Y328	KINGS 2128	Y636	T&B WT406M	Y321
TE (AMP) 69363	Y590	ASTRO. 615550	Y330	KINGS 2140	Y837P	T&B WT411	Y190
TE (AMP) 69365-3	Y950	BURNDY MR8PV-2	Y530	KINGS 2162	Y679	T&B WT414	Y191
TE (AMP) 69408	Y736	BURNDY MR8-PVS	Y524	KINGS 2168	Y932	T&B WT419	Y192
TE (AMP) 69422	Y737	BURNDY N14HET-25	Y881	KINGS 2175	Y940	TROMPETER CD5-10	Y776
TE (AMP) 69423	Y738	BURNDY N14RT-10	Y818	KINGS 2177	Y825	TROMPETER CD5-11	Y777
TE (AMP) 69424	Y739	BURNDY N22RVM-10	Y512	KINGS 2180	Y829P	TROMPETER CD5-8	Y778
TE (AMP) 69425	Y740	BURNDY N22RVM-15	Y817	KINGS 2207	Y888	TROMPETER CD5-12	Y789F
TE (AMP) 69429	Y741	BURNDY YAV9C-L36	Y948	KINGS 2211	Y889	TROMPETER CD5-13	Y803
TE (AMP) 69471	Y742	IT CANNON 249-1400-000	Y249P	KINGS 2212	Y890	TROMPETER CD5-4	Y631
TE (AMP) 69477-4	Y938	IT CANNON 304-0445-000	Y894	KINGS 2213	Y891	TROMPETER CD5-7	Y775
TE (AMP) 69493	Y743	IT CANNON 317-1795-000	Y694	KINGS 2213	Y910	TROMPETER CD5-9	Y687
TE (AMP) 69493-1	Y744	IT CANNON 317-2071-000	Y824	KINGS 2214	Y892	WALTER KIDDE M616229	Y412
TE (AMP) 69646	Y746	IT CANNON 317-7178-000	Y830	KINGS 2216	Y893		
TE (AMP) 69646	Y537	IT CANNON 990-001-391/392	Y358	KINGS 2229	Y911	Others Available. Consult DMC.	
TE (AMP) 69726	Y1998	IT CANNON 995-0001-761	Y704	MAC PANEL 452303	Y430-MP		
TE (AMP) 69811	Y747	IT CANNON 995-0002-113	Y702	MOLEX 8657-5001/2	Y922		
TE (AMP) 85-35181-SK11	Y692	IT CANNON 995-0002-143	Y708	MOLEX 86760-5003	Y926		

DMC does not provide connectors, contacts or wiring components. Parts shown here are for reference only. See disclaimer of liability on page 27.

Open Frame Crimp Tools

M22520/5-01 (HX4) M22520/10-01 (HX3)

The DMC HX4 and HX3 series crimp tools feature a system of interchangeable dies which eliminate the need for separate fixed die crimp tools for each and every different application. Many maintenance and production organizations have standardized on one of these models, thus eliminating the cost associated with maintaining and calibrating bulky inventories of single purpose, dedicated tools.

TYPICAL DIE SET

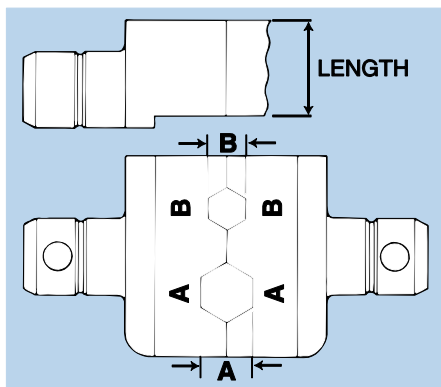

Tremendous flexibility and cost advantages exist with this crimping system due to the wide variety of military and proprietary interchangeable dies available for these tool frames. As new requirements evolve, a new set of dies is all that's required to meet the demand.

Crimping dies are snapped into the tool frame and retained in place by internal spring clips. They may be permanently secured, if desired, by pressing a roll pin into the holes provided.

The tool frames are equipped with a positive ratchet assembly which controls complete handle movement in both directions.

Hexagonal crimp dies are available in a variety of combinations having single, double, and even triple cavity design. These dies accommodate most coaxial and triaxial connectors and contacts conforming to MIL-DTL-39012, AS39029, and numerous proprietary configurations. Other designs are available for coaxial connections requiring different termination techniques.

Dies in various crimp patterns are also available for insulated and uninsulated terminal lugs, wire splices and end caps relating to M7928, MS17143, MS25036, MS25181, MS27429, MS25274, MS20659, M81824, MS21003 through MS21015, and commercial part numbers. Several power contacts too large for conventional hand tools are also covered by interchangeable dies for the standard tool frame (HX4).

If your application requirement is not already covered by one of our standard dies our engineering department will be pleased to discuss a design to suit your needs.

The HX4 is 11" in length and weighs approximately 21 oz. The HX3 is 9" in length and weighs 11 oz.

DMC169A (M83521/7-01) & DMC169 (M83507/9-01) TOOL KITS

The DMC169A and DMC169 tool kits consist of an HX4, Blade Micrometer, and 27 die sets. Each tool kit covers Mil-Spec shielding ferrules (MS21980/MS21981) and Mil-Spec coaxial contacts (M39029/6/13/14, M39029/7/8, M83733/13/14 and ON089558).



Open Frame Crimp Tool Die Part Numbers

DIE P/N			DIE CLOSURE DIMENSIONS			
DMC P/N *	MILITARY P/N	NATIONAL STOCK NO. N.S.N.	A HEX.	LENGTH	B HEX.	LENGTH
HX4	M22520/5-01	5120-01-335-8575	Standard Crimp Tool Frame			
Y200P	M22520/5-02	5120-01-335-8244	.091	.090	.068	.270
Y196	M22520/5-03	5120-01-335-8245	.128	.325	.105	.325
Y152	M22520/5-04	5120-01-335-8246	.138	.090	.118	.270
Y197	M22520/5-05	5120-01-335-8247	.213	.325	.178	.325
Y203	M22520/5-06	5120-01-335-8248	.128	.094		
Y195	M22520/5-07	5120-01-335-8249	.255	.325		
Y215	M22520/5-08	5120-01-335-8250	.128	.375		
Y204P	M22520/5-09	5120-01-335-8251	.178	.400	.068	.093
Y189	M22520/5-10	5120-01-335-8252	.160	.400		
Y205P	M22520/5-11	5120-01-335-8253	.213	.400	.068	.093
Y206P	M22520/5-13	5120-00-133-0585	.255	.400	.068	.093
Y207P	M22520/5-15	5120-01-335-8255	.263	.400	.068	.093
Y193	M22520/5-17	5120-00-133-0597	.118	.375		
Y142	M22520/5-19	5120-01-335-8257	.255	.400	.213	.400
Y149	M22520/5-21	5120-01-335-8258	.475	.400		
Y145	M22520/5-23	5120-01-335-8259	.384	.400		
Y110P	M22520/5-25	5120-01-335-8260	.429	.400	.100	.120
Y151	M22520/5-27	5120-01-335-8261	.532	.400		
Y109P	M22520/5-29	5120-01-335-8262	.324	.400	.100	.120
Y150	M22520/5-31	5120-01-335-8263	.501	.400		
Y136	M22520/5-33	5120-01-335-8264	.343	.400	.105	.400
Y137	M22520/5-35	5120-01-335-8265	.324	.400	.128	.400
Y138	M22520/5-37	5120-01-335-8266	.314	.400	.151	.400
Y139	M22520/5-39	5120-01-335-8267	.309	.400	.160	.400
Y140	M22520/5-41	5120-01-335-8268	.290	.400	.178	.400
Y141	M22520/5-43	5120-01-335-8269	.268	.400	.197	.400
Y143	M22520/5-45	5120-01-335-8270	.231	.400	.218	.400
Y144	M22520/5-47	5120-01-335-8271	.359	.400		
Y146	M22520/5-49	5120-00-133-0644	.401	.400		
Y147	M22520/5-51	5120-00-116-3040	.431	.400		
Y148	M22520/5-53	5120-01-335-8294	.454	.400		
Y102	M22520/5-55	5120-01-335-8295	.324	.400		
Y209P	M22520/5-57	5120-01-335-8296	.213	.400	.100	.120
Y208P	M22520/5-59	5120-01-335-8297	.255	.400	.100	.120
Y178	M22520/5-61	5120-01-335-8298	.429	.400		
Y314P	M22520/5-63	5120-01-335-8299	.263	.400	.091	.090

*Die part numbers ending in "P" indicate that the die set has an alignment guide pin.
**Contact DMC for QPL status.

DIE P/N			DIE CLOSURE DIMENSIONS			
DMC P/N *	MILITARY P/N	NATIONAL STOCK NO. N.S.N.	A HEX.	LENGTH	B HEX.	LENGTH
Y501	M22520/5-100	5120-00-126-0860	Pre-Insulated Terminal Crimp 26-10 AWG			
Y527	M22520/5-101	5120-01-335-8301	Pre-Insulated Splice Crimp 26-20 AWG			
Y539	M22520/5-102	5120-01-335-8302	Splice Crimp 12-1 6 AWG			
Y540	M22520/5-103	5120-01-335-8303	Splice Crimp 16-26 AWG			
Y631	M22520/5-105	5120-01-361-9554	.218	.307		
Y692	M22520/5-104	--	--			
Y1115	M22520/5-106**	--	Adjustable Insulation Terminal Crimp for Red 18-22 AWG			
Y1116	M22520/5-107**	--	Adjustable Insulation Terminal Crimp for Blue 14-16 AWG			
Y1117	M22520/5-108**	--	Adjustable Insulation Terminal Crimp for Yellow 10-12 AWG			

HX3	M22520/10-01	5120-00-117-4830	Miniature Crimp Tool Frame			
X115S	M22520/10-02	5120-01-335-8304	.091	.090	.068	.270
X103	M22520/10-03	5120-01-335-8305	.255	.325		
X123	M22520/10-04	5120-01-335-8277	.138	.090	.118	.270
X101	M22520/10-05	5120-01-335-8278	.128	.325	.105	.325
X125	M22520/10-06	5120-01-335-8279	.160	.400		
X102	M22520/10-07	5120-01-335-8280	.213	.325	.178	.325
X140	M22520/10-08	5120-01-335-8281	.128	.093		
X129	M22520/10-09	5120-01-335-8282	.118	.327		
X136	M22520/10-10	5120-01-335-8283	.128	.375		
X225	M22520/10-11	5120-01-335-8284	.105	.400		
X118	M22520/10-13	5120-01-335-8285	.128	.400		
X226	M22520/10-15	5120-01-335-8286	.151	.400		
X149	M22520/10-17	5120-01-335-8287	.178	.400		
X147	M22520/10-19	5120-01-335-8288	.197	.400		
X144	M22520/10-21	5120-01-335-8289	.213	.400		
X155	M22520/10-23	5120-01-335-8290	.218	.400		
X156	M22520/10-25	N/A	.231	.400		
X187	M22520/10-27	5120-01-335-8291	.255	.400		
X515	M22520/10-100	5120-00-116-3286	Terminal/Splice Crimp 12-10 AWG			
X511	M22520/10-101	5120-00-116-2992	Terminal/Splice Crimp 26-14 AWG			
X525	M22520/10-102	5120-01-335-8274	Terminal/Splice Crimp 26-20 AWG			
X527	M22520/10-103	5120-00-124-3734	Splice Crimp 16-12 AWG			
X528	M22520/10-104	5120-01-335-8276	Splice Crimp 26-16 AWG			

Battery Powered Hydraulic Open Frame Crimp Tool

GET THE PORTABILITY OF A HAND TOOL WITH THE STAMINA OF A POWER TOOL!

DMC is pleased to present our battery powered hydraulic tools to crimp copper and aluminum cable #26 to #10 AWG with DMC "Y" Dies (M22520/5-XX and others). These tools are equivalent to DMC's **HX4** hand tool and use the same Y-dies.

Working on today's electrical systems calls for increased mobility and repeatable, consistent crimping force. To satisfy this need, DMC offers a battery powered hydraulic crimp tool designed to integrate your current tooling systems. The ergonomic tool body helps reduce workplace injuries and eases operator fatigue keeping costs low and production high.

DMC battery powered tools have been engineered to work with our existing Y-die series and compliment our established crimp tools. And, as always, if we don't have a die to meet your needs, we will engineer and manufacture it for you.

FEATURES

- Ergonomic design allows one-handed operation
- Die automatically opens when crimp is complete
- Indicating complete crimp pressure cycle has been achieved
- Head rotates 350 degrees
- Red LED to display the charge status of the battery

CRIMP CAPACITIES

- #26 to #10 AWG (copper terminations)
- Max. Crimp Force: 1.5 Tons (13.3 kN)
- Avg. Crimp Time: 2 seconds
- Avg. Crimps per Charge: 200
- Charge Time: 15 mins (Avg.)

SPECIFICATIONS

- Length: 14.5" (368 mm)
- Width: 2.87" (72.9 mm)
- Depth: 4.5" (114.3 mm)
- Weight (with battery): 3.18 lb (1.4 kg)
- Sound Level: 75 db(A) at 1 meter
- Vibration: <8.2 ft/s² (2.5 m/s²)
- Hydraulic Oil: Shell Tellus® T-15

TOOL INCLUDES: Carrying Case, Gage, Die Removal Tool, Two 18v Batteries (p/n **HDE-LI-B**), One Battery Charger (p/n **HDE-LI-120C**).

Dies must be ordered separately.

ADJUSTABLE DIES FOR INSULATED TERMINALS & SPLICES		
COLOR	SIZE	P/N
Yellow	12-10	Y670, Y1117
Blue	16-14	Y671, Y1116
Red	22-18	Y672, Y1115
Yellow	26-24	Y678
Red/Blue	22-14	Y1060
Yellow/White	26-20	Y1061

Adjustable Crimping Dies accept terminations which conform to AS7928, AS25036 (class 1 and 2) and other military or commercial specifications.

HXE4B

The **HXE4B** Battery Powered Hydraulic Open Frame Crimp Tool is a hand held, self-contained crimp tool. The crimp head, battery, and pump unit are contained in one ergonomic tool body and weighs about 4 pounds. It is equivalent to DMC's **HX4** hand tool and uses the same Y-dies. (See pages 80-83)

HXE4AB

This tool is available with an optional spring loaded push rod to hold the product in the crimping position (dies normally closed). (P/N **HXE4AB**)

HXE4B-230

The **HXE4B-230** is supplied with a 230V charger.



HXE4B

Open Frame Crimp Tools



BENCH PRESS STYLE OPEN FRAME CRIMP TOOLS UDT5 & UDT3

The **UDT5** & **UDT3** tools have the die frame opening on the opposite side of the tool frame from the **HX4** & **HX3** so the tool can be used as a portable bench top press or as a hand tool. The tool frames are equipped with the same positive ratchet assembly and accept the same “Y” and “X” series dies. When used as a bench top press, the operator gains a greater mechanical advantage, thereby reducing operator fatigue.

Pneumatic Open Frame Tool HX33

The DMC **HX33** is a bench top pneumatic crimp machine that is compatible with M22520/5 military and many DMC “Y-die” series crimp dies. The die sets are interchangeable and can be easily installed and removed from the **HX33** pneumatic crimp tool.

Utilizing the enclosed foot pedal, the crimping cycle of the **HX33** is activated and allows the operator to have both hands free to insert the crimped item and wire. All **HX33** crimp tools are equipped with a positive closing mechanism to ensure consistent crimp quality.

The **HX33** has an emergency release button that will open the crimping jaws in the event of blocked jaws caused by operation or handling errors or wrongly placed terminals.

- Foot Pedal Activation
- Full Cycle Control
- CE Marked
- In-Line Die Closure
- Accepts Most “Y” Dies
- Dimensions: 11.8”L x 4.9”W x 10.2”H
- Weight With Foot Pedal: 32lbs
- Crimp Force: 4000lb @ 90PSI



HX33

Pneumatic Open Frame Tool HX23

HX23 BENCH CRIMP PRODUCTION PRESS

COMPATIBILITY WITH EXISTING CRIMP DIES

The **HX23** accommodates all M22520/5-XX military and DMC "Y" series crimp dies (see pages 80-83).

This affords total utilization of existing dies and total interchangeability with M22520/5-01 (Daniels **HX4**) handheld tool frames (see pages 80-83).

FULL CYCLE CONTROL

Full die closure is assured on every crimp. The internal cycle control network will not allow the tool to open until complete closure is attained. A simple procedure is available to open the tool in cases where a complete cycle cannot be effected. A secure method is provided to prevent unauthorized personnel from defeating the cycle control system.

HANDS FREE OPERATION

There are no awkward levers or mechanisms used to open or close the crimp dies. These operations waste time and distract the operator's attention.

TWO STAGE CRIMP PROCESS FOR OPERATOR SAFETY

When the tool is in the normal condition, the crimp dies are fully open where contact assemblies can easily be inserted. A touch of the foot valve releases the dies to a safe gripping position (spring pressure only). When the operator is satisfied that the contact assembly is positioned correctly and hands are in a safe position, another actuation of the same foot valve completes the crimp and quickly returns the die to the open position for removal of the crimped assembly and loading of the next parts.

MOUNTING

The **HX23** is supplied with a stable bench mount which can remain unattached for portability. Or, can be mounted to a workstation by installing fasteners through the holes provided.

The **HX23** Production Crimp Press can be used in horizontal or vertical

SAFETY FEATURES:

- 2 Step Crimping Process
- Emergency Stop Switch

HX23



BENCH MOUNT AND FOOT PRESS INCLUDED

positions.

OPERATOR SAFETY FEATURES

The **HX23** is equipped with a transparent guard which affords the protection, but does not restrict vision.

The Hands Free Operation system allows the operator to position the contact assembly while the die is under spring pressure only.

The operator is then free to let the tool hold the contact assembly during the crimp cycle while the operator's hands and fingers are a safe distance from the crimping die.

The **HX23** foot valve assembly is constructed with a protective shroud to prevent accidental actuation. For operation the operator places their foot under the shroud to depress the pedal.

FULL PNEUMATIC OPERATION

Standard clean, dry shop air at the recommended pressure is all that is required to operate the **HX23** tool. There are no electrical or hydraulic requirements.

ADJUSTABLE DIES FOR INSULATED TERMINALS & SPLICES

COLOR	SIZE	P/N
Yellow	12-10	Y670, Y1117
Blue	16-14	Y671, Y1116
Red	22-18	Y672, Y1115
Yellow	26-24	Y678
Red/Blue	22-14	Y1060
Yellow/White	26-20	Y1061

Adjustable Crimping Dies accept terminations which conform to AS7928, AS25036 (class 1 and 2) and other military or commercial specifications.

HX23 SPECIFICATIONS

COMPONENTS (ALL INCLUDED)	SIZE	WEIGHT
TOOL FRAME	4 x 6 x 16 (in)	11 LBS
	11.4 x 15.2 x 40.6 (cm)	5.2 KG
FOOT PRESS	4 x 5 x 13 (in)	6 LBS
	10.2 x 12.7 x 34.3 (cm)	2.7 KG
HOSE ASSM. (BETWEEN FOOT PRESS AND CRIMP TOOL)	9 Feet – 2.7 Meters	1.5 LBS

AIR REQUIREMENTS 80-95 PSI (5.4-6.4 BAR)

Open Frame Crimp Tools

EMC3300 Electro Mechanical Crimp Tool

FEATURES

- Advanced Ergonomic Tool Design with “Safe Distance” Trigger Closing Control
- Pre-Clamp Function to Improve Cycle Time and Quality
- Crimp Cycle Time is 1.3 Seconds
- 250 Crimps per Charge (typical battery life)
- Li-Ion 10.8 Volt Battery and Charger
- Built-in LED Light
- Data Retrieval Available



EMC3300

EMC3300

Ordering Guide

DMC P/N	Description
EMC3300	Tool Kit with 110-120 Volt Charger and one battery
EMC3300-230	Tool Kit with 220-240 Volt Charger and one battery
HDE-MBC110	110-120 Volt Charger only
HDE-MBC220	220-240 Volt Charger only
HDE-MBP108	10.8V Battery only
HDE-USB	USB Adapter Module

Available Dies and Gages

DMC DIE Part #	Application Notes	DMC GAGE Part #
EMC-101D	W, R, B, Y Insulated Spare Wire Caps (Comparable to TE58573-1)	A. G818, B. G819, C. G820, D. G821
EMC-102D	R, B, Y Insulated Terminals (Comparable to TE58423-1)	A. B. C. G931
EMC-102DL	Same as EMC-102D plus Locator	A. B. C. G931
EMC-105D	EQUIV. TO DCT4-105	None
EMC-106D	.042 sq, .128 hex, .178 hex	A. None, B. G1212, C. G1222
EMC-108D	.068 sq, .213 hex, .255 hex	A. G1287, B. G1257, C. G1188
EMC-117D	.128 hex, .178 hex, .213 hex, .255 hex (AMPHENOL SOCAPEX SX660-0062)	A. G1212, B. G1222, C. G1257, D. G1188
EMC-124D	.178 hex, .128 hex, .068 hex	A. G1222, B. G1212, C. G1287
EMC-129D	M81824/1-X splices (comparable to M22520/37-01, GMT232)	A. B. C. G411
EMC3300-197	Equivalent to TE 2063030-1	None
EMC-199D	Equivalent to T&B ERG4002	None
EMC-200D	Equivalent to TE 58628-2	A. G1362, B. G1363, C. G1364
EMC-203D	Equivalent to TE 59824-1 (Tetra Crimp Tool)	None
EMC-204D	Equivalent to TE 58630-1 tool for ULTRA-FAST 12-10 Terminals	A. G1146, B. G1189
EMC-209D	Equivalent to TE 217212-1	None
EMC-210D	Equivalent to T & B ERG4004	None
EMC3300-212	Equivalent to Molex 91528-1	None
EMC3300-213	Equivalent to Molex 91504-1	None
EMC-277D	Equivalent to GMT277	A.B.C.D G713
EMC-1005D	Uninsulated Terminals 10-22 AWG (Equiv to GMT1005, comparable to TE49935)	A. G739, B. G740, C. G741
EMC-1006D	High Temp Uninsulated Terminals 10-22AWG (Equiv to GMT1006, comparable to TE46447)	A. G327, B. G328, C. G329

DCT Series Crimp Tools

DMC provides custom and standard crimp tools that are manufactured to connector OEM or user requirements. Often these tools are specified as comparable in function to the OEM connector supplier tool.



The DCT series of crimp tools and dies accommodate most (insulated and uninsulated) terminals and splices conforming to AS7928 insulated and uninsulated as well as numerous proprietary configurations.

Dies in various crimp patterns are also available for D-Subminiature, circular connectors, Red/Blue/Yellow "Heat-N-Seal" terminals, "MiniSeal" terminals, and low profile environmental splices (M81824/1-XX).

Dies are configured with single, double, triple and even quadruple crimp cavities.

Several models and types of tools comprise the DCT tool series. Some tools have removable (interchangeable) dies, and others have fixed cavities that are not removable.

If your application requirement is not already covered by one of our standard die sets, our engineering department will be pleased to discuss a design to suit your needs, consult DMC for details.

DCT4-XXX SERIES HAND CRIMP TOOLS

The sturdy construction of the DCT hand tools is superior to any tool made today. The handle will not flex or bend in any direction, therefore maximum force and repeatability are achieved. The precision ratchet controls cycling of the tool and assures the same accurate crimp every time. The handle grips and the leverage system are designed for maximum ergonomic benefit.

The DCT tools are approximately 9¾" x 3⅛" x 1¼" and weigh 1.38 lbs.

DMC does not provide connectors, contacts or wiring components. Parts shown here are for reference only. See disclaimer of liability on page 27.

DCT Series Crimp Tools

DCT4 HAND TOOL SERIES DIES

DIE P/N	DESCRIPTION
DCT4-101	Insulated Spare Wire Caps Comparable to AMP 58573-1
DCT4-102	R/B/Y Insulated Terminals & Splices #22-18 AWG, 16-14 AWG, 12-10 AWG
DCT4-104	R/B/Y ROSTRA HEAT-N-SEAL
DCT4-105	Uninsulated Terminals
DCT4-106	RF Connectors .178/ .128 HEXES
DCT4-107	RF Connectors .068/.178/.324 HEXES
DCT4-108	.068/.213/.255 HEXES
DCT4-109	.213/.128/.105 HEXES
DCT4-110	TROMPETER CD3-2 with .324/.255/.068/.042 HEXES
DCT4-111	COAXIAL AND FIRE BOTTLE CAP INDICATOR .128 HEX
DCT4-117	.255/.213/.178/.128 HEXES
DCT4-118	.213/.178 HEXES
DCT4-119	Insulated Terminals & Splices # 24-20 AWG, # 22-18 AWG, AND # 16-14 AWG w/ Locator
DCT4-120	RG58/U, RG59/U, RG62/U .359/.255 HEXES
DCT4-121	.039 square/ .195 HEXES
DCT4-122	Insulated Terminals & Splices # 24-20 AWG, #22-18 AWG AND #16-14 AWG
DCT4-124	.068 / .128 / .178 HEXES Comparable to Amphenol CTL-9
DCT4-128	.211/.128/.105 HEXES CANNON CCT-DM Comparable to DieY322
DCT4-129	Same configuration as M22520/37-1 for M81824/1-X Splices Tyco (Raychem) "Mini-Seal" Environmental Splices (26-20, 20-16, 16-12)
DCT4-130	SUB-D CONTACTS 20-24/24-28
DCT4-138	Coaxial Crimp Tool .264/.161 HEXES
DCT4-139	.264/.220 HEXES
DCT4-140	.433/.402 HEXES
DCT4-141	B-CRIMP COND. & INS. 16-22 AWG, 14-16 AWG, 10-12 AWG
DCT4-142	with .142/.112/.079 HEXES
DCT4-144	Coaxial Crimp Tool .359/.290 HEXES
DCT4-145	Coaxial Crimp Tool .454 HEX
DCT4-147	.429/.100/.068 HEXES
DCT4-148	.268/.178 HEXES, .057 dia.

DCT4 HAND TOOL SERIES DIES

DIE P/N	DESCRIPTION
DCT4-149	COAXIAL CABLE ST212, ST214, BT2002, BT3002 .268/.213/.178/.150 HEXES
DCT4-151	D-SUBMINIATURE 20-30 AWG
DCT4-154	.028 / .047 SQ, .128 / .178 HEXES
DCT4-155	.028 / .047 SQ, .15 / .268 HEXES
DCT4-157	.211 / .252 / .068 HEXES
DCT4-158	.212 / .252 / .066 HEXES
DCT4-160	.041 gage for "B" crimp
DCT4-161	.041 gage for "B" crimp
DCT4-162	.042 gage for "B" crimp
DCT4-163	.290 DIA cavity
DCT4-166	.187 / .178 HEXES, .042 SQ Comparable to Amphenol CTL-15
DCT4-167	.324 / .319 / .255 HEXES, .042 SQ Comparable to Amphenol CTL-14
DCT4-169	.324 / .255 / .068 HEXES, .052 SQ Comparable to Amphenol CTL-8
DCT4-170	.290 / .128 / .105 HEXES
DCT4-173	Rosenberger 88K20K-0S-3H3
DCT4-175	AMP Multimate III & VI
DCT4-176	Comparable to DIE Y498
DCT4-178	"B" Crimp
DCT4-179	"B" Crimp
DCT4-180	Tyco AMPMODU Series Type IV, IV1/2 & V Contacts Comparable to AMP 90340
DCT4-181D	Molex 734154550 (1 of 2)
DCT4-182D	Molex 734154550 (2 of 2)
DCT4-183	.339 HEX
DCT4-185	White and Yellow Terminals
DCT4-187	.215 / .225 / .235 HEXES
DCT4-188	.110 HEX
DCT4-189	Comparable to MRP0478
DCT4-191	Comparable to BURNDY MR8-9Q
DCT4-192	Comparable to AMP 68064

GMT Series Crimp Tools

DMC provides custom and standard crimp tools manufactured to OEM connector supplier or user requirements. Often these tools are specified as comparable in function to the OEM connector supplier tool. Numerous applications such as open barrel (stamped and formed) contacts, insulated and non-insulated terminals, splices, end caps, coaxial connectors, and wire fittings of all types are covered by these tools. The rugged construction of this tool assures repeatability and long life cycle. You can rely on DMC experience for quality and cost effective performance.



GMT General Purpose Tools: Many standard OEM applications are covered by the GMT general purpose tool series. The jaws are fixed, and the locator (where used) is configured to hold the contacts precisely in the correct location for optimum crimping.

GMT1090 (M22520/44-01) TOOL FOR M81824/12-XX COLD APPLIED SPLICES

The **GMT1090 (M22520/44-01)** Hand Crimp Tool crimps Tyco's Cold Applied Environmental Splices (M81824/12-xx) sizes 26-20, 20-16, 16-12 AWG. This precise tool has a locator which is configured to hold the splice in the correct location while either wire is being terminated. No heat required.



GMT232 (M22520/37-01) TOOL FOR M81824/1, /6, /7, /8, /9, /10, /11, /13, & /14 ENVIRONMENTAL SPLICES

The **GMT232 (M22520/37-01)** Hand Crimp Tool crimps low profile environmental splices (M81824/1). The **GMT232** is the most popular tool to cover the range of 12 (yellow), 16 (blue), and 20 (red) splices for low profile environmental splice applications. The **GMT232** has a locator which is configured to hold the splice in the correct location while either wire is being terminated. This tool is comparable to the popular Tyco AD1377. Pneumatic Equiv. **PMT232**.



GMT333 (M22520/38-02*) Tool for M20659 UNINSULATED TERMINALS

The **GMT333** Tool is Pending Qualification to AS22520/38 as a replacement for the superseded M22520/24 plier crimp tool, and as an alternative to AS22520/38-01. The conductor crimp cavities have been split into three separate cavities instead of just two for improved crimp quality. The **GMT333** has also maintained the cycle control ratchet and leverage advantages of **GMT277**. The **GMT337** tool is used to crimp the insulation support crimp of M20659 terminals that have that feature. Sizes 22-18 & 16-14.



GMT1005 TOOL FOR UNINSULATED TERMINALS

The **GMT1005** Hand Crimp Tool terminates uninsulated terminals sizes 10 to 22 AWG. This tool is comparable to Tyco Electronics' 49935 hand tool. Pneumatic Equiv. **PMT1005**.



GMT1006 TOOL FOR UNINSULATED TERMINALS

The **GMT1006** Hand Crimp Tool terminates uninsulated terminals sizes 10 to 22 AWG. This tool is comparable to Tyco Electronics' 46447 hand tool. Pneumatic Equiv. **PMT1006**.



*QPL in progress

GMT Series Crimp Tools

GMT TOOL SERIES PART NUMBERS						
MILITARY P/N	DMC HAND TOOL P/N	DMC BATTERY TOOL P/N (SEE NEXT PAGE)	DMC PNEUMATIC TOOL P/N	APPLICATION / DESCRIPTION	MILITARY GAGE P/N	DMC GAGE P/N
--	GMT201	GMTE201B	PMT201	Molex .093" Dia, Contacts Accm. 1189-1190, 1380-1381, 1450-1451, 1589-1590	--	--
--	GMT202	GMTE202B	PMT202	Molex .093" Dia, Contacts Accm. 1560-1561, 1786-1787	--	--
--	GMT203	GMTE203B	PMT203	Molex .156" KK Trifurcon Series, Contacts Accm. 2477-2478, 2870-2871	--	--
--	GMT204	GMTE204B	PMT204	Molex .093" Dia Claspcon Series, Contacts Accm. 1433-1434, 6893-6894	--	--
--	GMT206	GMTE206B	PMT206	ITT Cannon Zif Connector, Series DL, Contacts Accm. 030-2064-010, 014, 028	--	--
--	GMT208	GMTE208B	PMT208	Tyco Multimate Type III+ Series. Contacts Accm. 66099, 66101, 66103, 66105, 66107, 66109, 66646, 66589, 66590, 66593, 66596, 66237, 66242, 66306, 66311	--	--
--	GMT209	GMTE209B	PMT209	Elco 60-8017-0313. Contact Accm. Z841-Z842, 60-8017-0313	--	--
--	GMT211	GMTE211B	PMT211	Tyco PCB Terminals and Disconnects, .058" dia. Contacts Accm. 60983, 60789	--	--
--	GMT220	GMTE220B	PMT220	Tyco Type XI Contacts Accm. 203802, 203816, 203874, 203875	--	--
--	GMT221	GMTE221B	PMT221	Rockwell Collins Thin-Line I & II. Contacts Accm. 372-2514-080, 372-2514-010	--	G648
--	GMT225	GMTE225B	PMT225	Tyco AMP MOD U Series Type MOD IV Contacts Accm. 86015, 86016, 87045-87046, MP2500, MT2500	--	--
--	GMT226	GMTE226B	PMT226	Tyco Amplimite Series, Size 20DF, Contacts Accm. 66504-66507 1801-004, 005, 006, 020, 021, 022	--	--
--	GMT230	GMTE230B	PMT230	Tyco AMP MOD U Series Type IV, IV1/2 & V Contacts Accm. 87045-87046, 87522-87523, 87309-87110, 87195, 87313, 3010-02102-0100	--	--
M22520/37-01	GMT232	GMTE232B	PMT232	M81824/1-X Splices Tyco (Raychem) "Mini-Seal" Environmental Splices (26-20, 20-16, 16-12)	M22520/39-01	G411
--	GMT241	GMTE241B	PMT241	Tyco CPC Series, Size 20DF, Contacts Accm. 205201-205202, 205310-205311	--	--
--	GMT245	GMTE245B	PMT245	Tyco Mate-N-Lok Series 60620 and 60619	--	--
--	GMT247	GMTE247B	PMT247	ITT Cannon D-Sub Economy Standard Size 20, Contacts Accm. D1100238-34, 35	--	--
--	GMT248	GMTE248B	PMT248	Comparable to Pyle-National TP-201389 (w/ Cutter)	--	--
--	GMT260	GMTE260B	PMT260	ITT Cannon DL Series ZIF Contacts Accm. 030-2064-028/031	--	--
--	GMT262	GMTE262B	PMT262	Tyco Amp-TAB Series 66168, 66143, 66169, 66144	--	--
--	GMT263	GMTE263B	PMT263	Teradyne 600-0026-000 I/O Series, Contacts Accm. 001-6500-51	--	--
M22520/38-01	GMT277	GMTE277B	PMT277	MS20659 Uninsulated Ring terminals size 22 through 10 and MS25486 external power plug socket contact size 12 (Supersedes M22520/24-01)	--	G714
--	GMT286	GMTE286B	PMT286	TE Contact Accm. 925576	--	--
--	GMT295	GMTE295B	PMT295	TE Contact Accm. 87165	--	--
--	GMT302	GMTE302B	PMT302	ITT Cannon CCT-UBC	--	--
--	GMT309	GMTE309B	PMT309	Amp Tyco Tool 144969-2	--	--
M22520/38-02*	GMT333	GMTE333B	PMT333	MS20659 Uninsulated Ring terminals size 22 through 10 and MS25486 external power plug socket contact size 12 (Supersedes M22520/38-01)	--	--
--	GMT1005	GMTE1005B	PMT1005	Uninsulated Terminals (Tyco Tool 49935)	--	G739, G740, G741
--	GMT1006	GMTE1006B	PMT1006	TYCO 46447	--	G327 G328 G329
M22520/44-01	GMT1090	GMTE1090B	N/A	TE Cold Applied Environmental Splice (26-20, 20-16, 16-12)	M22520/39-03	G1122
M22520/47-01*	GMT335	GMTE335	PMT335	Standard Crimp for AS7928/15 Flag Shape Terminals	AS22520/3-26 for Cav. AB AS22520/3-27 for Cav. C	--

*QPL in progress

Battery Powered Hydraulic GMT Series Crimp Tools

DMC's GMT Series battery powered hydraulic tools are designed to crimp open barrel (stamped and formed) contacts, insulated and non-insulated terminals, splices, and end caps, coaxial connectors, and wire fittings of all types. Just like with the hand tools, locators are included for applications where they are needed to hold contacts in the correct location for optimum crimping.

GMTExxxB

The **GMTExxxB** Series Battery Powered Hydraulic Commercial Standard Crimp Tools are hand held, self-contained crimp tools. The crimp head, battery, and pump unit are contained in one ergonomic tool body and weigh about 4 pounds each. They are equivalent to DMC's GMT Series hand tools.

TOOL INCLUDES: Carrying Case, Two 18v Batteries (p/n HDE-LI-B), One Battery Charger (p/n HDE-LI-120C).



GMTExxxB-230

The **GMTExxxB-230** is supplied with a 230V charger.

GMTE232B FOR M81824/1-XX ENVIRONMENTAL SPLICES

GMTE232B Tool is the battery powered equivalent to our GMT232 (M22520/37-1) hand tool for low profile environmental splices (M81824/1-XX). The **GMTE232B** is the most popular GMT Series tool to cover the range of 12 (yellow), 16 (blue), and 20 (red) splices for low profile environmental splice applications. This precise tool has a locator which is configured to hold the splice in the correct location while either wire is being terminated.

FEATURES

- Ergonomic design allows one-handed operation
- Jaws remain closed under spring pressure (pinch sides to open/load) for safety and holding termination in place
- Head rotates 350 degrees
- Red LED to display the charge status of the battery

CRIMP CAPACITIES

- Max. Crimp Force: 4 Tons (35.6 kN)
- Avg. Crimp Time: 3 seconds
- Avg. Crimps per Charge: 100
- Avg. Charge time: 15 minutes

SPECIFICATIONS

- Length: 13" (330 mm)
- Width: 2.87" (72.9 mm)
- Depth: 4.5" (114.3 mm)
- Weight (with battery): 2.8 lb (1.3 kg)
- Hydraulic Oil: Shell Tellus® T-15 (or equivalent)

TOOL PART NUMBERS

- See page 93 column 3

GMTExxxB



PMT232 Pneumatic Crimp Tool ***For M81824/1, /6, /7, /8, /9, /10, /11, /13, & /14 Environmental Splices***



The **PMT232** Pneumatic Crimp Tool crimps low profile environmental splices (M81824/1-xx), AWG range 12 (yellow), 16 (blue), and 20 (red).



The **PMT232** is cycle-controlled and has a locator which is configured to hold the splice in the correct location while either wire is being terminated. The tool is 8" long, 2" wide and weighs 2.5 lbs. Air supply requirements are 80-120 PSI (5.5 to 8.0 bar) clean dry air.



The **PMT232** can be hand held, or mounted on a bench stand (P/N BM-2A).

DMC provides custom and standard crimp tools manufactured to OEM or user requirements. The **PMT232** is functionally similar to TE Connectivity's AD1377 and AD1377S.

Hand and Battery Powered Versions are Available!



GMT232 Hand Tool
Qualified to M22520/37-01



GMTE232B
Battery Tool

Hydrac™ Hydraulic 3.5 Ton Crimping Tool for HD36 Dies

Large Gage Crimp Tools

HD36 MANUAL HYDRAULIC TOOL

HD36 Hydraulic Crimper is a combination of a lightweight design and the precise application of 3.5 tons force to crimp power contacts too large for conventional hand tools. This tool is designed to accept the entire family of D36 dies for crimping terminals, lugs or any other special applications.

The 3.5 ton crimp force is achieved through multiple actuations of the tool handle. The automatic relief valve “clicks” audibly when the proper crimp force has been applied to prevent over-compression. The tool head also rotates 360 degrees for easy accessibility in confined working areas. The hand tool is 8.5” long, weighs only 3.3 lbs, and is operated with one hand.

If your application requirement is not already covered by one of our standard dies, our engineering department will be pleased to discuss a design to suit your needs, consult DMC for details.

- 3.5 tons of die force.
- Interchangeable die sets.
- Automatic relief valve to prevent over-compression
- Release lever for relaxing crimp pressure and opening dies mid-cycle
- 180° rotating head for ease in confined work areas.
- Each tool supplied in a fitted carrying case



HD36 TOOL SERIES DIES

DIE SET P/N	“A” CRIMP HEIGHT	“A” LENGTH	“B” CRIMP HEIGHT	“B” LENGTH	TYPE/APPLICATION
HD36-101	.552-DIA.	0.180			Single Cavity Circular Corresponds To HUSKIE HD-58
HD36-102	.420-RAD.	0.180			Single Cavity Circular Corresponds To HUSKIE HD-34
HD36-103	0.530	0.365			Single Cavity HEX
HD36-104	.750-GAGE	0.225			Single Cavity HEX, Corresponds To HOMAC 840
HD36-105N	0.198	0.185			Single Cavity HEX
HD36-106N	0.222	0.185			Single Cavity HEX
HD36-107N	0.280	0.155			Single Cavity HEX
HD36-109	.520-GAGE	0.340			Single Cavity HEX, Corresponds To HOMAC 5/8
HD36-110N	0.530	0.344			Corresponds To T&B 683-53701-1
HD36-111N	.135-GAGE	0.312			#8 Non-Insulated Single Indent
HD36-112N	.126-GAGE	0.312			#6 Non-Insulated Single Indent
HD36-113N	.206-GAGE	0.344			#4 Non-Insulated Single Indent
HD36-114N	.265-GAGE	0.344			#2 Non-Insulated Single Indent
HD36-115N	0.226	0.110	0.169	0.110	Double Cavity HEX Corresponds To PEN-011-2, & PEN-011-3
HD36-116N	0.284	0.110	0.114	0.110	Double Cavity HEX Corresponds To PEN-011-1, & PEN-011-4
HD36-124	0.390	0.344			Single Cavity HEX
HD36-125	0.600	0.344			Single Cavity HEX
HD36-126	0.217	0.344			Single Cavity HEX
HD36-128	0.160	0.344			Single Cavity HEX
HD36-130	.130-GAGE	0.344			Single Indent for Flag Terminals
HD36-131	0.446	0.344			1/0 Non-Insulated Terminal Lug
HD36-132	0.487	0.344			2/0 Non-Insulated Terminal Lug
HD36-135	0.110	0.100			HDE36 GAGING DIE
HD36-136	.240 GAGE	0.375			#6 INSULATED (BLUE), Corresponds To AMP 1490598-1
HD36-137	.272 GAGE	0.375			#4 Insulated (YELLOW), Corresponds To AMP 1490599-1
HD36-138	.176 GAGE	0.202	0.111	0.202	Non-Insulated Single Indent
HD36-139	.204 GAGE	0.250			#8 Insulated (RED), Corresponds To AMP 1490597-1
HD36-142	.144 SQ.	0.344			Single Cavity Circular



DMC does not provide connectors, contacts or wiring components. Parts shown here are for reference only. See disclaimer of liability on page 27.

Battery Powered Hydraulic 4 Ton Crimp Tool for HD36 Dies

HDE36B BATTERY POWERED HYDRAULIC CRIMP TOOL FOR HD36 DIES



HDE36B

The **HDE36B** Battery Powered Crimp Tool offers the portability of a hand tool with the stamina of a power tool! It is a hand held, self-contained, 4 ton hydraulic crimp tool that is actuated with a single squeeze of the trigger.

This tool is designed to accept the entire family of **HD36** dies for crimping terminals, lugs or any other special applications. WIRE RANGE: #8 to #0 AWG* in many power applications, and .750 (19.05mm) in coaxial hexagonal crimping.

The **HDE36B** offers a solution where the volume of work exceeds the physical limits of a worker with hand tools, and hoses and cables are unwelcome or unsafe for the environment where the work is being performed.

The **HDE36B** battery tool is approximately 13.25" long, 2.87" wide, and 4.5" deep, and weighs 2.8 lbs with the battery installed.

TOOL INCLUDES: Carrying Case, Two 18v Batteries (p/n **HDE-LI-B**), One Battery Charger (p/n **HDE-LI-120C**).

DIE SELECTION: The crimper will accommodate all crimp dies listed on page 96. Other applications may be covered by this tool. Consult DMC for details.

* Wire range will vary depending on wire and terminal/contact.

FEATURES

- Ergonomic design allows one-handed operation
- Die automatically opens when crimp is complete
- Die can be retracted in mid-cycle to adjust connector
- Head rotates 350 degrees
- Red LED to display the current status of the unit

CRIMP CAPACITIES

- Max. Crimp Force: 4 Tons (35.6 kN)
- Avg. Crimp Time: 3 seconds
- Avg. Crimps per Charge: 100

SPECIFICATIONS

- Length: 13.25" (356 mm)
- Width: 2.87" (72.9 mm)
- Depth: 4.5" (114.3 mm)
- Weight (with battery) 2.8 lb (1.3 kg)
- Sound Level: 75 db(A) at 1 meter
- Vibration: <8.2 ft/s² (2.5 m/s²)
- Hydraulic Oil: Shell Tellus® T-15

Heavy Duty Indent Crimp Tool

WA23 (M22520/23-01) PNEUMATIC INDENT CRIMP TOOL

DMC's heavy pneumatic indent crimp tool functions with the push of a button for operator ease. This heavy duty crimp tool accommodates large size contacts 8 through 4/0 (AWG) and operates on standard 90–125 psi (5.4–8.16 BAR) shop air sources.

It is engineered with the operator's safety in mind and features a full cycle control system. This tool is portable and needs no extra booster for large size contacts.

The standard die assembly and positioner are easily interchangeable with no special tool required. Custom dies and positioners may be designed to specific requirements. An optional foot pedal is available upon request.

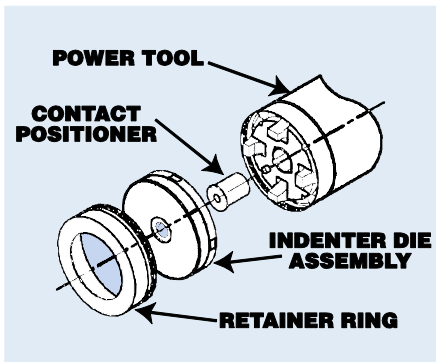

Portable hydraulic versions are available. Both the manual **HD23** and the battery powered **HDE23B** use all of the same dies and positioners as the **WA23**.
*QPL in progress

M22520/23 TOOL, DIE AND LOCATOR LIST

MIL #	DESCRIPTION	DMC #
M22520/23-01	Crimp Tool	WA23
M22520/23-02	Die Assy. 8	WA23-2
M22520/23-03	Die Assy. 6	WA23-3
M22520/23-04	Die Assy. 4	WA23-4
M22520/23-05	Die Assy. 1/0	WA23-5
M22520/23-06	Die Assy. 2/0	WA23-6
M22520/23-07	Die Assy. 4/0	WA23-7
M22520/23-08	Die Assy. 1	WA23-8
M22520/23-09	Positioner 8	WA23-9
M22520/23-10	Positioner 6, 6N, 6G	WA23-10
M22520/23-11	Positioner 4	WA23-11
M22520/23-12	Positioner 4, 4N, 4G	WA23-12
M22520/23-13	Positioner 1/0	WA23-13
M22520/23-14	Positioner 1/0, 1/0N	WA23-14
M22520/23-15	Positioner 2/0, 2/0N	WA23-15
M22520/23-16	Positioner 4/0, 4/0N	WA23-16

M22520/23 TOOL, INSPECTION GAGING INFORMATION

DIE ASSEMBLY	CONTACT SIZE	"GO"	"NO-GO"	GAGE P/N
M22520/23-02	8	.130	.136	G693
M22520/23-03	6	.171	.178	G694
M22520/23-04	4	.195	.202	G695
M22520/23-05	0	.325	.332	G696
M22520/23-06	00	.351	.358	G697
M22520/23-07	0000	.425	.432	G698
M22520/23-08	1	.255	.265	G1299

Pico* to DMC Part Number Guide

PICO* LOCATOR	PICO DIE ASSEMBLY	DMC LOCATOR	DMC DIE ASSEMBLY	CONTACTS	AWG
4046A	414DA-8N	WA23-9 M22520/23-Q9	WA23-2 M22520/23-02	M39029/29-214 M39029/30-220, M39029/44-291 M39029/45-298	8
4297-6	414DA-6N	WA23-10 M22520/23-10	WA23-3 M22520/23-03	M39029/48-317 M39029/48-318 M39029/48-319, M39029/49-329 M39029/49-330	6
4112	414DA-4N	WA23-11 M22520/23-11	WA23-4 M22520/23 -04	M39029/29-215 M39029/30-221, M39029/44-292 M39029/45-299	4
4297-5	414DA-4N	WA23-12 M22520/23-12	WA23-4 M22520/23-04	M39029/48-320 M39029/48-321 M39029/48-322, M39029/49-331 M39029/49-332	4
4066	414DA-1/0N 414DA-0N	WA23-13 M22520/23-13	WA23-5 M22520/23-05	M39029/29-216 M39029/30-222 M39029/44-293 M39029/45-300	1/0
4297-3	414DA-1/0N 414DA-0N	WA23-14 M22520/23-14	WA23-5 M22520/23-05	M39029/48-323 M39029/48-324 M39029/49-333	1/0
4297-2	414DA-2/0N	WA23-15 M22520/23-15	WA23-6 M22520/23 -06	M39029/48-325 M39029/48-326 M39029/49-334	2/0
4297-1	414DA-4/0N-I	WA23-16 M22520/23-16	WA23-7 M22520/23 -07	M39029/48-327 M39029/48-328 M39029/49-335	4/0
4536	414DA-10N	WA23-102L	WA23-101DA	EUROPEAN NORM # EN3155003 F 1010, EN3155008 F 1010	10
N/A	414DA-4N	WA23-111L	WA23-4 M22520/23-04	BENDIX - AMPHENOL # 10-113474-4P, 10-113474-4S, 10-229193-4S, 10-229192-4P	4
N/A	414DA-1/0N 414DA-0N	WA23-113L	WA23-5 M22520/23-G5	BENDIX - AMPHENOL # 10-113474-1P, 10-113474-1S	1/0
N/A	414DA-12N	WA23-114L	WA23-168DA	M39029/56-353 M39029/58-365	12
N/A	414DA-12N N/A	WA23-115L	WA23-168DA WA23-169DA	M39029/11-147 M39029/12-151	12 14
4117	414DA-12N N/A 414DA-16N	WA23-116L	WA23-168DA WA23-169DA WA23-170DA	M39029/4-113 M39029/5-118 M39029/29-213 M39029/30-219 M39029/44-289 M39029/44-290, M39029/45-297	12 14 16
4001	414DA-8N	WA23-117L	WA23-2 M22520/23.02	ITT Cannon # 031-0560-081, 330-0351-008	8
4060 ITT Cannon CCHP8-7	414DA-8N	WA23-119L	WA23-2 M22520/23-02	ITT Cannon # 031-0733-000	8
N/A	414DA-8N	WA23-121L	WA23-2 M22520/23-02	FRANKLIN ELECTRIC # 151378-101, 151378-102, 151378-103	8
4234	414DA-4N	WA23-122L	WA23-4 M22520/23-04	ITT Cannon # 030-8613-000 , 031-8520-000, 330-0351-004, 330-0351- 041 (METRIC) 031-8591-000, 031-8560-000	4
4233	414DA-1/0N 414DA-0N	WA23-123L	WA23-5 M22520/23-05	ITT Cannon # 030-8614-000, 031-8521-000, 330-0351-000, 330-0351-001 (METRIC) 031-8561-000, 030-8592-000	1/0
N/A	414DA-8N	WA23-145L	WA23-2 M22520/23-Q2	ITT Cannon # 030-8590-000, 030-8612-000, 031-8519-000, 031-8559-000	8
N/A	414DA-1/0N 414DA-0N	WA23-146L	WA23-5 M22520/23 -05	HAKO MINUTEMAN # 4 LUGS	4
4329	414DA-8N	WA23-147L	WA23-2 M22520/23-02	LITTON-VEAM # 27935-T9 27915-T9	8
4042	414DA-1/0N 414DA-0N	WA23-148L	WA23-5 M22520/23-05	LITTON-VEAM # 27937-VT9 27917-VT9	1/0
N/A	414DA-8N 414DA-6N 414DA-4N	WA23-149L	WA23-2 M22520/23-02 WA23-3 M22520/23-03 WA23-4 M22520/23-04	AMP-TYCO # 213179-1 (8Ga.) 213178-1 (6Ga.) 213177-1 (4Ga.)	8 6 4

*Pico is a trade name for the The Pico Corporation.

DMC does not provide connectors, contacts or wiring components. Parts shown here are for reference only. See disclaimer of liability on page 27.

Pico* to DMC Part Number Guide

PICO* LOCATOR	PICO DIE ASSEMBLY	DMC LOCATOR	DMC DIE ASSEMBLY	CONTACTS	AWG
N/A	414DA-8N 414DA-6N 414DA-4N	WA23-150L	WA23-2 M22520/23-02 WA23-3 M22520/23-03 WA23-4 M22520/23-04	AMP-TYCO # 213183-1 (8Ga.) 213182-1 (6Ga.) 213181-1 (4Ga.)	8 6 4
5002	414DA-12-10 ITT	WA23-153L	WA23-154DA (12Ga.) WA23-152DA (10Ga.) FORM CRIMP		12/10
4025 4026	414DA-8N	WA23-161L	WA23-2 M22520/23-02	BENDIX - AMPHENOL # 10-40792 P, 10-40793 S 10-113239-8S, 10-113239-8P, 10-113474-8P, 10-113474-8S	8
4231	N/A	WA23-162L	WA23-112DA	BENDIX - AMPHENOL # 10-40561	12
4043	414DA-4N	WA23-163L	WA23-4 M22520/23-04	BENDIX - AMPHENOL # 10-40564, 10-40565	4
N/A	414DA-6N 414DA-4N	WA23-164L	WA23-3 M22520/23-03 WA23-4 M22520/23-04	AMP-TYCO # 92-0940-11-3 (4 Ga.) 92-0940-11-6 (6 Ga.)	6 4
N/A	414DA-6N 414DA-4N	WA13-166L	WA23-3 M22520/23-03 WA23-4 M22520/23-04	AMP-TYCO # 92-0940-9-2 (4 Ga.) 92-0940-9-9 (6 Ga.)	6 4
4116	414DA-16N	WA23-171L	WA23-170DA	M39029/4-111 M39029/5-116 M39029/29-212 M39029/30-218 M39029/44-288 M39029/45-295	16
N/A	414DA-4N	WA23-176L	WA23-4 M22520/23-04	AMP-TYCO # 93-1813-36-3, 93-1813-36-6, 93-1813-36-9	4
N/A	414DA-4N	WA23-177L	WA23-4 M22520/23-04	AMP-TYCO # 93-1813-37-3	4
N/A	414DA-8N 414DA-10N 414DA-12N	WA23-178L	WA23-2 M22520/23-02 WA23-101DA WA23-168DA	AMP-TYCO # 93-1813-49-9, 93-1813-50-9, 93-1813-52-9	8 10 12
N/A	414DA-8N 414DA-10N 414DA-12N	WA23-179L	WA23-2 M22520/23-02 WA23-101DA WA23-168DA	TYCO 93-1813-49-6 , 93-1813-50-6, 93-1813-52-6	8 10 12
N/A	414DA-8N 414DA-10N 414DA-12N	WA23-180L	WA23-2 M22520/23-02 WA23-101DA WA23-168DA	TYCO 93-1813-49-, 93-1813-50-3, 93-1813-52-3	8 10 12
N/A	414DA-4N	WA23-182L	WA23-4 M22520/23-04	ANDERSON POWER # 1319G4 (4 AWG) 1319 (2 AWG)	4 2
5007-1	414DA-2 ITT	WA23-185L	WA23-184DA RADIAL CRIMP		2
N/A	414DA-8N	WA23-186L	WA23-2 M22520/23-02	AMP-Tyco # 213552-2 (P)	8
4150	414DA-12N	WA23-187L	WA23-168DA	PYLE NATIONAL ZZM-40 12-36, ZZM-4112-36, ZZM-40 12-50, ZZM-4112-50	12
N/A	414DA-16N	WA23-188L	WA23-170DA	PYLE NATIONAL ZZM-4016-3, ZZM-4116-36, ZZM-4016-50, ZZM-4116-50	16
N/A	414DA-8N	WA23-189L	WA23-2 M22520/23-02	ITT Cannon # 030-0560-081	8

* Pico is a trade name for the The Pico Corporation.

DMC does not provide connectors, contacts or wiring components. Parts shown here are for reference only. See disclaimer of liability on page 27.

Pico* to DMC Part Number Guide

PICO* LOCATOR	PICO DIE ASSEMBLY	DMC LOCATOR	DMC DIE ASSEMBLY	CONTACTS	AWG
4070	414DA-4N	WA23-190L	WA23-4 M22520/23-04	ITT Cannon # 031-0560-041	4
N/A	414DA-8N	WA23-195L	WA23-2 M22520/23-02	BENDIX - Amphenol # 10-497086-085	12 (x 2) 8
N/A	414DA-6 ITT	WA23-196L	WA23-130DA RADIAL- CRIMP	AMP-TYCO # 52264-1 HOLLINGSWORTH # R4004BF WILCOX ELECT. 025997-0003	6
N/A	414DA-8N	WA23-205L	WA23-2 M22520/23-02	HONEYWELL DRAWING # 414-0508 (S), 414-0509 (P)	8
N/A	414DA-4N	WA23-208L	WA23-4 M22520/23-04	M39029/45-299 M39029/44-292	4
N/A	414DA-6N	WA23-209L	WA23-3 M22520/23-02	TYCO #322006 THOMAS & BETTS # 54136	6
N/A	414DA-6N	WA23-210L	WA23-3 M22520/23-02	THOMAS & BETTS # 54205	6
N/A	414DA-2 NIT	WA23-211L	WA23-198DA RADIAL CRIMP	THOMAS & BETTS # 54148,54208	2
N/A	414DA 10N	WA23-215L	WA23-101DA	HARTING: 0932 000 6107, 0932 000 6108, 0932 000 6207, 0932 000 6208	10
N/A	414DA-8N 14DA-6N	WA23-217L	WA23-2 M22520/23-02 (12,10,8) WA23-3 M22520/23-03 (6)	ANDERSON POWER # 5915 (10-12 AWG) 1307 (6-8 AWG), 1383-BK (2AWG), 947 (2AWG)	2 6 8 10 12
4046A	N/A	WA23-223L-BX	WA23-218DA	AMPHENOL # NZGC-C-8PB, NZGC-C-8SB	8
4112	N/A	WA23-224L-BX	WA23-219DA	AMPHENOL# NZGC-C-4PB, NZGC-C-4SB	4
4301-16S	414DA-16N-048	WA23-225L	WA23-226DA	DEUTSCH # 0460-202-16141, 0462-201-16141	16
N/A	414DA-12N	WA23-227L	WA23-168DA	ANDERSON POWER # 1331	14 SOLID
N/A	414DA-8N	WA23-231L	WA23-2 M22520/23-02	CENTERLIFT PUMPS #36697	8
N/A	414DA-6N	WA23-232L	WA23-3 M22520/23-03	CENTERLIFT PUMPS #36698	6
N/A	414DA-4N	WA23-233L	WA23-4 M22520/23-04	CENTERLIFT PUMPS #51200	4
N/A	414DA-8N	WA23-234L	WA23-2 M22520/23-02	COOPER CROUSE-HINDS # 3326376-1	8
N/A	414DA-8N	WA23-236L	WA23-2 M22520/23-02	COOPER CROUSE-HINDS # 132-6371-1	8
N/A	414DA-12N	WA23-237L	WA23-168DA	AMP-TYCO # 212008-1	12 WIRE BARREL
N/A	414DA-8N	WA23-237L	WA23-168DA M22520/23-02	AMP-TYCO # 211161-1	8

Dieless 4 Indent Crimpers

DMC's Dieless 4-Indent Crimpers provide a symmetrical 4-sided crimp (at 90° intervals). Dies of a particular configuration are not needed. The crimp pressure against the resistance of the metal conductor assembly will cause the tool to crimp to a depth where there is metal to metal bottoming (gas tight crimp joint on aluminum and soft copper).

The range of crimping capabilities starts with 6 AWG conductors and goes to 4/0 AWG conductors on copper, and 750 MCM applications on aluminum.

Triangle indenter shape is standard. Optional indent designs are available. Consult DMC.



XHC136 REMOTE HEAD HYDRAULIC TOOL



HCE136B DIELESS BATTERY POWERED 4 INDENT CRIMPER



HC136 DIELESS MANUAL 4 INDENT CRIMPER

XHC136

The **XHC136** can be a hand held crimp head (pump options below) or mounted. This is intended to crimp copper and aluminum lug terminals & splices. The **XHC136** crimps sizes 6 AWG to 4/0 AWG conductors on copper, and up to 750 MCM applications on aluminum.

HC136B

The **HCE136B** is a hand held, self contained battery crimp tool intended to crimp copper and aluminum lug terminals & splices. The **HCE136B** crimps sizes 6 AWG to 4/0 AWG conductors on copper, and up to 750 MCM applications on aluminum.

HC136

The **HC136** crimps sizes 6 AWG to 4/0 AWG conductors on copper, and up to 750 MCM applications on aluminum.

PUMPS

DMC offers several pump options that offer economical, efficient, reliable methods to power the **XHC136**. The powered pumps are: a pneumatic pump (P/N **HPU11M**), and a DC electric battery pump (P/N **HPU13M**). Two portable manual pumps: a hand pump (p/n **HPU12M**) and a foot pump (p/n **HPU15M**). All pumps come with a heavy duty, ten-foot long hose and couplings (equipped with screw on MS fittings and dust covers) to complete the connection between pump and crimper (P/N **12-4040**).

**M525441-5
HPU11M
(Pneumatic)**



**HPU13M
(Battery)**



**HPU12M
(Hand)**



**HPU15M
(Foot)**



HD51 Hydraulic 5.5 Ton Crimping Tool

Large Gage Crimp Tools

HD51 Medium Duty Hydraulic Crimper is the most popular hand operated hydraulic crimper. The HD51 is still lightweight at 4.6 lbs., but the 5.5 tons of die force and the larger die configuration extends the range of crimping capabilities to 2/0 AWG* conductors in many applications. The HD51 Hydraulic Crimper utilizes rugged construction, lightweight materials, and comfortable handle grips for the best ergonomic advantage. The number of handle closures required to complete the crimp is reduced by the larger and more efficient hydraulic pump system. Other features are the following:

- Length: 14" (356 mm)
- Weight 4.6 lbs. (2.08kg)
- Crimp force: 5.5 tons (48.93kN)
- Automatic relief valve to prevent over-compression
- Release lever for relaxing crimp pressure and opening dies
- 180° rotating head for ease in confined work areas.
- WIRE RANGE: (#12 to #2/0 AWG in many power applications, and .700 (17.78mm) in coaxial hexagonal crimping.

*Wire range will vary depending on wire and terminal/contact.

BATTERY POWERED VERSION AVAILABLE



HDE51B BATTERY POWERED HYDRAULIC CRIMPER

XHD51 Remote Hydraulic Crimp Head is a preferred solution for high yield applications on production lines and maintenance rework centers. A pumping system provides the hydraulic power to the remote crimping head, and the crimp head can be mounted in a stationary position, or used as a hand-held tool. Pump options are listed below. Other specifications that apply to the XHD51 are the following:

- Length: 7.1 inches (180.3mm)
- Weight 3.85 pounds (1.74kg)
- Crimp force: 5.5 tons (48.93kN)

DMC1383 Tool Kit contains the HD51 hand tool and all the dies for crimping insulated and uninsulated terminals and splices size 8 through 2/0. This tool kit is contained in a metal case with foam inserts that have contoured tool cavities, laminated instruction sheets permanently attached on a ring binder, and contents charts identifying the location of each tool.

WIRE RANGE: #12 to #2/0 AWG in many power applications, and .700 (17.78mm) in coaxial hexagonal crimping.



HD51 DIES

Pump options for the XHD51 crimp head:
 HPU11M: Pneumatic powered hydraulic pump
 HPU12M: Hand powered hydraulic pump
 HPU13M: DC Battery powered electric pump
 HPU15M: A foot pump

Consult DMC for complete brochure and information on all ASS259 hydraulic crimp tools and accessories.

AS5259 STANDARD PART NUMBER REFERENCE GUIDE		
Military (SAE) Part Number	DMC Part Number	Description
M5259/4-01*	XHD51	Remote Crimp Head
M5259/5-01*	HD51	Manual Hydraulic Crimp Tool
M5259/6-01 thru 06*	Consult DMC for Details	Gages for HD51 Indent Dies
M5259/7-001 thru -019*	See Next Page for Details	Crimping Die Sets

Complete AS5259 Product Brochure Available from DMC

*Contact DMC for QPL status



XHD51 REMOTE HYDRAULIC CRIMP HEAD (M5259/4-01)

HD51 MEDIUM DUTY HYDRAULIC CRIMPER (M5259/5-01)

HD51/XHD51/HDE51B Dies

HD51 TOOL SERIES DIES

DMC P/N	A. CAVITY	A. LENGTH	B. CAVITY	B. LENGTH	APPLICATION	MILITARY GAGE P/N	DMC GAGE P/N
HD51-101	.325	.125	.216	.187	.325 / .216, Hexes	N/A	None
HD51-105	.170	.250			For Insulated Terminals Size 8	N/A	G682
HD51-106	.202	.312			For Insulated Terminals Size 6	N/A	G683
HD51-107	.254	.375			For Insulated Terminals Size 4	N/A	G684
HD51-110	.530	.365			.530, Hex	N/A	None
HD51-112	.440	.358	.538	.358	.440 / .538, Hexes	N/A	None
HD51-113	.312	.470			For Insulated Terminals Size 2	N/A	G801
HD51-114N	.115	.312			For Uninsulated AS7928 Copper Terminals and AS7974 Contacts Size 8 (Single Indent)	N/A	G1150
HD51-115N	.126	.312			For Uninsulated AS7928 Copper Terminals and AS7974 Contacts Size 6 (Single Indent)	N/A	G1151
HD51-116N	.131	.312			For Uninsulated AS7928 Copper Terminals and AS7974 Contacts Size 4 (Single Indent)	N/A	G1152
HD51-117N	.190	.312			For Uninsulated AS7928 Copper Terminals and AS7974 Contacts Size 2 (Single Indent)	N/A	G1153
HD51-118N	.115	.312			For Uninsulated AS7928 Copper Terminals and AS7974 Contacts Size 8 (Double Indent)	M5259/6-001	G1150
HD51-119N	.126	.312			For Uninsulated AS7928 Copper Terminals and AS7974 Contacts Size 6 (Double Indent)	M5259/6-002	G1151
HD51-120N	.131	.312			For Uninsulated AS7928 Copper Terminals and AS7974 Contacts Size 4 (Double Indent)	M5259/6-003	G1152
HD51-121N	.190	.312			For Uninsulated AS7928 Copper Terminals and AS7974 Contacts Size 2 (Double Indent)	M5259/6-004	G1153
HD51-122N	.275	.470			For Uninsulated AS7928 Copper Terminals and AS7974 Contacts Size 1/0 (Single Indent)	N/A	G1154
HD51-123N	.275	.470			For Uninsulated AS7928 Copper Terminals and AS7974 Contacts Size 1/0 (Double Indent)	M5259/6-005	G1154
HD51-124N	.320	.470			For Uninsulated AS7928 Copper Terminals and AS7974 Contacts Size 2/0 (Double Indent)	M5259/6-006	G1155
HD51-125N	.320	.470			For Uninsulated AS7928 Copper Terminals and AS7974 Contacts Size 2/0 (Single Indent)	N/A	G1155
HD51-127	.445	.250	.395	.200	.445 / .395, Hexes	N/A	None
HD51-130-1	R .100 H .300				#2 - #8 Uninsulated Needs HD51-131-2 or HD51-132-2	N/A	None
HD51-131-2	R .275		R .145		#2 & #8 Uninsulated Needs HD51-130-1	N/A	G744, G747
HD51-132-1	R .219		R .188		#4 & #6 Uninsulated Needs HD51-130-1	N/A	G745, G746
HD51-133-2	.312		.170		#2 & #8 Insulated Needs HD51-113-1 for #2 & HD51-105-1 for #8	N/A	G801 (#2), G682 (#8)
HD51-134-2	.202		.254		#4 & #6 Insulated Needs HD51-106-1 for #6 & HD51-107-1 for #4	N/A	G683 (#6), G684 (#4)
HD51-138	.377	.435			#2 Uninsulated .377, Hex MS90485-2 Equiv.	N/A	G833
HD51-139	.587	.400			.587 Hex	N/A	None
HD51-140	.956		.500		.956 & .500 Hex	N/A	G836
HD51-144	.140	.470			.140 Hex	N/A	G1376
HD51-148	.216				.216 Hex	N/A	G1327
HD51-149	.660	.400			.660 Hex	N/A	None
HD51-150	.352	.470			AB Twinax Pin & Socket Contacts Hex	N/A	None
HD51-152	.304	.470			Packard Hughes .437 Ferrules Gage	N/A	None
HD51-154	.339	.437			For Insulated Terminals Size 1 MS23002-1 Equiv.	N/A	G726
HD51-157					#10 Flag Terminal	N/A	None
HD51-159	.312	.470			#2 AWG Insulated Hex	N/A	None
HD51-160	.500	1.300			#2 Uninsulated For Aluminum Wire, Hex	N/A	G836
HD51-163P	.210	.310			For Uninsulated Terminals Size 8, Functional Equiv MS90485-8	N/A	G720
HD51-164P	.240	.310			For Uninsulated Terminals Size 6, Functional Equiv MS90485-6	N/A	G721
HD51-165P	.299	.372			For Uninsulated Terminals Size 4, Functional Equiv MS90485-4	N/A	G722
HD51-166P	.417	.435			For Uninsulated Terminals Size 1, Functional Equiv MS90485-1	N/A	G834
HD51-167P	.456	.435			For Uninsulated Terminals Size 1/0, Functional Equiv MS90485-01	N/A	G835
HD51-168P	.500	.470			For Uninsulated Terminals Size 2/0, Functional Equiv MS90485-02	N/A	G836

Hydraulic 12 Ton Crimping Tools for HD002, HD485, and HD442 Dies (AS5259)

HD120 Heavy Duty Hydraulic Crimper delivers the die force necessary to crimp large conductors, but still in a hand operated hydraulic crimper. The **HD120** produces 12 tons with the two stage pump that minimizes the number of handle closures needed to complete the crimp. The utilization of the **HD002 (MS23002)**, **HD485 (MS90485)**, and **HD442 (MS25442)** dies extends the range of crimping capabilities to 4/0 AWG conductors in military/aerospace applications. (Verification available upon request. Contact/terminal samples required.) Boeing ST 2354 Series Dies are also available from DMC. The **HD120** Hydraulic Crimper is fitted with comfortable handle grips for the best ergonomic advantage. A battery version, the **HDE120B** is also available.

- 360° rotating head for ease in confined work areas.
- Advance closing to crimp position is achieved by rotating the handle
- Automatic relief valve to prevent over-compression
- Release lever for relaxing crimp pressure and opening dies
- Crimp force: 12.0 tons (106kN)
- Length: 21.3 inches (541 mm)
- Weight 14.6 pounds (6.6 kg)



HD120 HEAVY DUTY HYDRAULIC CRIMPER

TBHD1M Remote Hydraulic Crimp Head (**MS25441-1**) exerts 12 tons of crimp force and extends the range of crimping capabilities to 4/0 AWG conductors in military/aerospace applications. The **TBHD1M** accepts the **HD002 (MS23002)**, **HD485 (MS90485)**, **HD442 (MS25442)** and Boeing ST 2354 die combinations. In some cases the tool can be used as a hand-held crimper, but the tool weight (9.6 lbs) and force means mounting it in a stationary position with a bench mount (**BM-2A**) is the preferred mode of operation. The recommended hydraulic pumps are listed on page 100 or you can consult DMC for other hydraulic pump options.

Other Specifications that apply to the TBHD1M are the following:

- Crimp force: 12.0 tons (107kN)
- Length: 10.0 inches (254 mm)
- Width: 6.0 inches (152.4 mm)
- Weight: 9.6 pounds (6.9 kg)



MS25441-1 QUALIFIED TO AS5259/1 (SHOWN WITHOUT SAFETY CAGE)

Contact DMC for a complete brochure on all AS5259 crimp tools and accessories.



HD002 DIES



HD442 DIES



HD485 DIES

Hydraulic 12 Ton Crimping Tools for HD002, HD485, and HD442 Dies (AS5259)

MS23002* DIES & GAGES FOR MS25036 INSULATED TERMINALS

MIL DIE P/N *	DMC P/N	COMMENTS	MIL GAGE P/N *	DMC GAGE P/N
MS23002-8	HD002-8	For Insulated Size 8	MS23003-8	G723
MS23002-6	HD002-6	For Insulated Size 6	MS23003-6	G724
MS23002-4	HD002-4	For Insulated Size 4	MS23003-4	G725
MS23002-2	HD002-2	For Insulated Size 2	MS23003-2	G281
MS23002-1	HD002-1	For Insulated Size 1	MS23003-1	G726
MS23002-01	HD002-01	For Insulated Size 1/0	MS23003-01	G727
MS23002-02	HD002-02	For Insulated Size 2/0	MS23003-02	G728
MS23002-03	HD002-03	For Insulated Size 3/0	MS23003-03	G282
MS23002-04	HD002-04	For Insulated Size 4/0	MS23003-04	G729

MS90485* DIES & GAGES FOR MS20659 UNINSULATED TERMINALS

MIL DIE P/N*	DMC P/N	COMMENTS	MIL GAGE P/N *	DMC GAGE P/N
MS90485-8	HD485-8	For Uninsulated Size 8	MS90486-8	G720
MS90485-6	HD485-6	For Uninsulated Size 6	MS90486-6	G721
MS90485-4	HD485-4	For Uninsulated Size 4	MS90486-4	G722
MS90485-2	HD485-2	For Uninsulated Size 2	MS90486-2	G833
MS90485-1	HD485-1	For Uninsulated Size 1	MS90486-1	G834
MS90485-01	HD485-01	For Uninsulated Size 1/0	MS90486-01	G835
MS90485-02	HD485-02	For Uninsulated Size 2/0	MS90486-02	G836
MS90485-03	HD485-03	For Uninsulated Size 3/0	MS90486-03	G837
MS90485-04	HD485-04	For Uninsulated Size 4/0	MS90486-04	G838

MS25442* DIES & GAGES FOR AS70991 UNINSULATED TERMINALS

MIL DIE P/N *	DMC P/N	COMMENTS	MIL GAGE P/N *	DMC GAGE P/N
MS25442-8A	HD442-8A	For Uninsulated Size 8	MS25472-1	G1129
MS25442-6A	HD442-6A	For Uninsulated Size 6	MS25472-2	G1130
MS25442-4A	HD442-4A	For Uninsulated Size 4	MS25472-3	G1131
MS25442-2A	HD442-2A	For Uninsulated Size 2	MS25472-4	G1132
MS25442-1A	HD442-1A	For Uninsulated Size 1	MS25472-5	G1133
MS25442-01A	HD442-01A	For Uninsulated Size 1/0	MS25472-6	G1134
MS25442-02A	HD442-02A	For Uninsulated Size 2/0	MS25472-7	G1135
MS25442-03A	HD442-03A	For Uninsulated Size 3/0	MS25472-8	G1136
MS25442-04A	HD442-04A	For Uninsulated Size 4/0	MS25472-9	G1137

DESCRIPTION	PART NO.	MIL P/N *
Manual Hydraulic Tool (12 ton force)	HD120	N/A
Battery Hydraulic Tool (12 ton force)	HDE120B	N/A
Remote Crimp Head (12 ton force) (Requires Air to Hydraulic Pump)	TBHD1M *	MS25441-1 *
Hose Assembly (6 Ft. Length)	12-4040	MS25441-3*
In-Line Pressure Gauge	HPU11-PG	N/A

DMC1948 Tool Kit contains the TBHD1M Crimp Tool, HPU11M Pump 12-4040, Hose Assembly, and all the HD002 (MS23002) and HD485 (MS90485) dies for crimping insulated and uninsulated terminals and splices size 8 through 4/0. This tool kit is contained in a molded, high-density plastic case with foam inserts that have contoured tool cavities, laminated instruction sheets permanently attached on a ring binder, and contents charts identifying the location of each tool.

DMC1966 Tool Kit contains the TBHD1M Crimp Tool, HPU11M Pump 12-4040, Hose Assembly, and all the HD442 (MS25442) dies for crimping uninsulated aluminum terminals and splices size 8 through 4/0. This tool kit is contained in a molded, high-density plastic case with foam inserts that have contoured tool cavities, laminated instruction sheets permanently attached on a ring binder, and contents charts identifying the location of each tool.

HPU11-PG In-Line Hydraulic Pressure Gauge is recommended for cycle control monitoring, when using Remote Crimp Heads with HPU1M, HPU12M or HPU15M. It installs into either end of the hydraulic line to monitor the hydraulic pressure. The gauge will indicate to the operator when the required hydraulic pressure is achieved.

Hydraulic Pumps:

DMC offers several Hydraulic Pump options for use with crimp heads.

Pump options include:

HPU11M: Pneumatic powered hydraulic pump
HPU12M: Hand powered hydraulic pump
HPU13M: DC Battery powered electric pump
HPU15M: A foot pump

NOTE:

HPU13M features automatic cycle control and die retraction upon cycle completion.

More detailed product literature is available. Consult DMC.

***Qualified to AS5259/1 (Tool Head) and AS5259/7 (Crimp Dies) Specification for Large Gage Crimp Tools**

DMC does not provide connectors, contacts or wiring components. Parts shown here are for reference only. See disclaimer of liability on page 27.



Similar Terminal Shown

M7928/1-1 to -10, Sizes 26 to 24

TYPE: Class 1 Insulated Terminals, Insulation Restricting

INSULATION: Nylon, UL 94V-2

TERMINAL BODY & SLEEVE: Copper, ASTM B-152

PLATING: Nickel, QQ-N-290, or Tin, ASTM B-545

MAX TEMP RATING: 105° C

Tool Selection Guide

TERMINAL SPECS					DMC TOOL/DIE OPTIONS					
AWG	WIRE SIZE (MM)	INSULATION DIAMETER IN. (MM)	SLEEVE COLOR	TERMINAL/SPLICE PART NUMBER	HX3 SERIES DIE MIL-APPROVED	HX4 SERIES DIE MIL-APPROVED (MULTI-CAVITY)	HX4 SERIES DIE MIL-APPROVED (SINGLE CAVITY)	HX4 SERIES DIE (SINGLE CAVITY)	M22520/40-01 TOOL MIL-APPROVED	
#26	0.15	.026-.055 (0.66-1.40)	Yellow w/ Black Stripe	M7928/1-	1	X511	Y501	Y1115*	Y672	AMT4001
					2	X511	Y501	Y1115*	Y672	AMT4001
					3	X511	Y501	Y1115*	Y672	AMT4001
					4	X511	Y501	Y1115*	Y672	AMT4001
					5	X511	Y501	Y1115*	Y672	AMT4001
#24	0.24	.031-.055 (0.79-1.40)	Yellow w/ Blue Stripe	M7928/1-	6	X511	Y501	Y1115*	Y672	AMT4001
					7	X511	Y501	Y1115*	Y672	AMT4001
					8	X511	Y501	Y1115*	Y672	AMT4001
					9	X511	Y501	Y1115*	Y672	AMT4001
					10	X511	Y501	Y1115*	Y672	AMT4001

*QPL in progress, die set includes insulation adjustment feature

Terminal Manufacturers' Part Numbers

TERMINAL SPECS			TERMINAL MANUFACTURERS' TERMINAL #						
AWG	SLEEVE COLOR	TERMINAL/SPLICE PART NUMBER	BURNDY	HOLLINGSWORTH	MOLEX	PANDUIT	THOMAS&BETTS	TYCO ELEC	
#26	Yellow w/ Black Stripe	M7928/1-	1	--	--	--	--	--	53078
			2	--	--	--	--	--	53049
			3	--	--	--	--	--	53050
			4	--	--	--	--	--	53051
			5	--	--	--	--	--	53052
#24	Yellow w/ Blue Stripe	M7928/1-	6	--	--	--	--	--	53053
			7	--	--	--	--	--	53054
			8	--	--	--	--	--	53055
			9	--	--	--	--	--	53056
			10	--	--	--	--	--	53057

NOTE: Component manufactures' and OEM instructions shall take precedence over the information presented in these charts. Wire ranges are for reference only.

HX4 TOOL SERIES OPTIONS FOR Y-DIES

HX4 Hand Tools, p. 90 & 91
 HXE4B Battery Tools, p. 92
 HX23 Pneumatic Tool, p. 94

HX3 TOOL SERIES OPTIONS FOR X-DIES

HX3 Hand Tools, p. 90 & 91

DMC does not provide connectors, contacts or wiring components. Parts shown here are for reference only. See disclaimer of liability on page 27.



Similar Terminal Shown

M7928/1-11 to -19, Size 22

TYPE: Class 1 Insulated Terminals, Insulation Restricting

INSULATION: Nylon, UL 94V-2

TERMINAL BODY & SLEEVE: Copper, ASTM B-152

PLATING: TIN, ASTM B-45

MAX TEMP RATING: 105° C

Tool Selection Guide

TERMINAL SPECS					DMC TOOL/DIE OPTIONS					
AWG	WIRE SIZE (MM)	INSULATION DIAMETER IN. (MM)	SLEEVE COLOR	TERMINAL/SPLICE PART NUMBER	HX3 SERIES DIE MIL-APPROVED	HX4 SERIES DIE MIL-APPROVED (MULTI-CAVITY)	HX4 SERIES DIE MIL-APPROVED (SINGLE CAVITY)	HX4 SERIES DIE (SINGLE CAVITY)	M22520/40-01 TOOL MIL-APPROVED	
#22	0.38	.038-.110 (0.97-2.79)	Red w/ Green Stripe	M7928/1-	11	X511	Y501	Y1115*	Y672	AMT4001
					12	X511	Y501	Y1115*	Y672	AMT4001
					13	X511	Y501	Y1115*	Y672	AMT4001
					14	X511	Y501	Y1115*	Y672	AMT4001
					15	X511	Y501	Y1115*	Y672	AMT4001
					16	X511	Y501	Y1115*	Y672	AMT4001
					17	X511	Y501	Y1115*	Y672	AMT4001
					18	X511	Y501	Y1115*	Y672	AMT4001
					19	X511	Y501	Y1115*	Y672	AMT4001

*QPL in progress, die set includes insulation adjustment feature

Terminal Manufacturers' Part Numbers

TERMINAL SPECS			TERMINAL MANUFACTURERS' TERMINAL #						
AWG	SLEEVE COLOR	TERMINAL/SPLICE PART NUMBER	BURNDY	HOLLINGSWORTH	MOLEX	PANDUIT	THOMAS&BETTS	TYCO ELEC	
#22	Red w/ Green Stripe	M7928/1-	11	--	--	--	--	--	52273
			12	--	--	--	--	--	2-36149-3
			13	--	--	--	--	--	51863-2
			14	--	--	--	--	--	1-320551-2
			15	--	--	--	--	--	2-36153-3
			16	--	--	--	--	--	2-320571-3
			17	--	--	--	--	--	2-320572-2
			18	--	--	--	--	--	2-320573-1
			19	--	--	--	--	--	2-328975-1

NOTE: Component manufactures' and OEM instructions shall take precedence over the information presented in these charts. Wire ranges are for reference only.

HX4 TOOL SERIES OPTIONS FOR Y-DIES

HX4 Hand Tools, p. 90 & 91
 HXE4B Battery Tools, p. 92
 HX23 Pneumatic Tool, p. 94

HX3 TOOL SERIES OPTIONS FOR X-DIES

HX3 Hand Tools, p. 90 & 91

DMC does not provide connectors, contacts or wiring components. Parts shown here are for reference only. See disclaimer of liability on page 27.



Similar Terminal Shown

M7928/1-20 to -28, Size 20

TYPE: Class 1 Insulated Terminals, Insulation Restricting

INSULATION: Nylon, UL 94V-2

TERMINAL BODY & SLEEVE: Copper, ASTM B-152

PLATING: Nickel, QQ-N-290, or Tin, ASTM B-545

MAX TEMP RATING: 105° C

Tool Selection Guide

TERMINAL SPECS					DMC TOOL/DIE OPTIONS					
AWG	WIRE SIZE (MM)	INSULATION DIAMETER IN. (MM)	SLEEVE COLOR	TERMINAL/SPLICE PART NUMBER	HX3 SERIES DIE MIL-APPROVED	HX4 SERIES DIE MIL-APPROVED (MULTI-CAVITY)	HX4 SERIES DIE MIL-APPROVED (SINGLE CAVITY)	HX4 SERIES DIE (SINGLE CAVITY)	M22520/40-01 TOOL MIL-APPROVED	
#20	0.60	.046-.110 (1.17-2.79)	Red w/ Red Stripe	M7928/1-	20	X511	Y501	Y1115*	Y672	AMT4001
					21	X511	Y501	Y1115*	Y672	AMT4001
					22	X511	Y501	Y1115*	Y672	AMT4001
					23	X511	Y501	Y1115*	Y672	AMT4001
					24	X511	Y501	Y1115*	Y672	AMT4001
					25	X511	Y501	Y1115*	Y672	AMT4001
					26	X511	Y501	Y1115*	Y672	AMT4001
					27	X511	Y501	Y1115*	Y672	AMT4001
					28	X511	Y501	Y1115*	Y672	AMT4001

*QPL in progress, die set includes insulation adjustment feature

Terminal Manufacturers' Part Numbers

TERMINAL SPECS			TERMINAL MANUFACTURERS' TERMINAL #						
AWG	SLEEVE COLOR	TERMINAL/SPLICE PART NUMBER	BURNDY	HOLLINGSWORTH	MOLEX	PANDUIT	THOMAS&BETTS	TYCO ELEC	
#20	Red w/ Red Stripe	M7928/1-	20	--	--	--	--	--	52273-1
			21	--	--	--	--	--	2-36149-4
			22	--	--	--	--	--	51863-3
			23	--	--	--	--	--	1-320551-3
			24	--	--	--	--	--	2-36153-4
			25	--	--	--	--	--	2-320571-4
			26	--	--	--	--	--	2-320572-3
			27	--	--	--	--	--	2-320573-2
			28	--	--	--	--	--	2-328975-2

NOTE: Component manufactures' and OEM instructions shall take precedence over the information presented in these charts. Wire ranges are for reference only.

HX4 TOOL SERIES OPTIONS FOR Y-DIES

HX4 Hand Tools, p. 90 & 91
 HXE4B Battery Tools, p. 92
 HX23 Pneumatic Tool, p. 94

HX3 TOOL SERIES OPTIONS FOR X-DIES

HX3 Hand Tools, p. 90 & 91

DMC does not provide connectors, contacts or wiring components. Parts shown here are for reference only. See disclaimer of liability on page 27.



Similar Terminal Shown

M7928/1-29 to -37, Size 18

TYPE: Class 1 Insulated Terminals, Insulation Restricting

INSULATION: Nylon, UL 94V-2

TERMINAL BODY & SLEEVE: Copper, ASTM B-152

PLATING: Nickel, QQ-N-290, or Tin, ASTM B-545

MAX TEMP RATING: 105° C

Tool Selection Guide

TERMINAL SPECS				DMC TOOL/DIE OPTIONS						
AWG	WIRE SIZE (MM)	INSULATION DIAMETER IN. (MM)	SLEEVE COLOR	TERMINAL/SPLICE PART NUMBER	HX3 SERIES DIE MIL-APPROVED	HX4 SERIES DIE MIL-APPROVED (MULTI-CAVITY)	HX4 SERIES MIL-APPROVED (SINGLE CAVITY)	HX4 SERIES DIE (SINGLE CAVITY)	M22520/40-01 TOOL MIL-APPROVED	
#18	0.96	.056-.110 (1.42-2.79)	Red w/ White Stripe	M7928/1-	29	X511	Y501	Y1115*	Y672	AMT4001
					30	X511	Y501	Y1115*	Y672	AMT4001
					31	X511	Y501	Y1115*	Y672	AMT4001
					32	X511	Y501	Y1115*	Y672	AMT4001
					33	X511	Y501	Y1115*	Y672	AMT4001
					34	X511	Y501	Y1115*	Y672	AMT4001
					35	X511	Y501	Y1115*	Y672	AMT4001
					36	X511	Y501	Y1115*	Y672	AMT4001
					37	X511	Y501	Y1115*	Y672	AMT4001

*QPL in progress, die set includes insulation adjustment feature

Terminal Manufacturers' Part Numbers

TERMINAL SPECS			TERMINAL MANUFACTURERS' TERMINAL #						
AWG	SLEEVE COLOR	TERMINAL/SPLICE PART NUMBER	BURNDY	HOLLINGSWORTH	MOLEX	PANDUIT	THOMAS&BETTS	TYCO ELEC	
#18	Red w/ White Stripe	M7928/1-	29	--	--	--	--	--	52273-2
			30	--	--	--	--	--	2-36149-5
			31	--	--	--	--	--	51863-4
			32	--	--	--	--	--	1-320551-4
			33	--	--	--	--	--	2-36153-5
			34	--	--	--	--	--	2-320571-5
			35	--	--	--	--	--	2-320572-4
			36	--	--	--	--	--	2-320573-3
			37	--	--	--	--	--	2-328975-3

NOTE: Component manufactures' and OEM instructions shall take precedence over the information presented in these charts. Wire ranges are for reference only.

HX4 TOOL SERIES OPTIONS FOR Y-DIES

HX4 Hand Tools, p. 90 & 91
 HXE4B Battery Tools, p. 92
 HX23 Pneumatic Tool, p. 94

HX3 TOOL SERIES OPTIONS FOR X-DIES

HX3 Hand Tools, p. 90 & 91

DMC does not provide connectors, contacts or wiring components. Parts shown here are for reference only. See disclaimer of liability on page 27.



Similar Terminal Shown

M7928/1-38 to -46, Size 16

TYPE: Class 1 Insulated Terminals, Insulation Restricting
INSULATION: Nylon, UL 94V-2
TERMINAL BODY & SLEEVE: Copper, ASTM B-152
PLATING: Nickel, QQ-N-290, or Tin, ASTM B-545
MAX TEMP RATING: 105° C

Tool Selection Guide

TERMINAL SPECS					DMC TOOL/DIE OPTIONS					
AWG	WIRE SIZE (MM)	INSULATION DIAMETER IN. (MM)	SLEEVE COLOR	TERMINAL/SPLICE PART NUMBER	HX3 SERIES DIE MIL-APPROVED	HX4 SERIES DIE MIL-APPROVED (MULTI-CAVITY)	HX4 SERIES MIL-APPROVED (SINGLE CAVITY)	HX4 SERIES DIE (SINGLE CAVITY)	M22520/40-01 TOOL MIL-APPROVED	
#16	1.42	.063-.130 (1.60-3.30)	Blue w/ Blue Stripe	M7928/1-	38	X511	Y501	Y1116*	Y671	AMT4001
					39	X511	Y501	Y1116*	Y671	AMT4001
					40	X511	Y501	Y1116*	Y671	AMT4001
					41	X511	Y501	Y1116*	Y671	AMT4001
					42	X511	Y501	Y1116*	Y671	AMT4001
					43	X511	Y501	Y1116*	Y671	AMT4001
					44	X511	Y501	Y1116*	Y671	AMT4001
					45	X511	Y501	Y1116*	Y671	AMT4001
					46	X511	Y501	Y1116*	Y671	AMT4001

*QPL in progress, die set includes insulation adjustment feature

Terminal Manufacturers' Part Numbers

TERMINAL SPECS			TERMINAL MANUFACTURERS' TERMINAL #						
AWG	SLEEVE COLOR	TERMINAL/SPLICE PART NUMBER	BURNDY	HOLLINGSWORTH	MOLEX	PANDUIT	THOMAS&BETTS	TYCO ELEC	
#16	Blue w/ Blue Stripe	M7928/1-	38	--	--	--	--	--	52274
			39	--	--	--	--	--	2-320561-3
			40	--	--	--	--	--	51864-6
			41	--	--	--	--	--	1-51864-0
			42	--	--	--	--	--	51864-7
			43	--	--	--	--	--	2-320563-3
			44	--	--	--	--	--	2-320575-2
			45	--	--	--	--	--	2-320564-1
			46	--	--	--	--	--	2-328976-1

NOTE: Component manufactures' and OEM instructions shall take precedence over the information presented in these charts. Wire ranges are for reference only.

HX4 TOOL SERIES OPTIONS FOR Y-DIES

HX4 Hand Tools, p. 90 & 91
 HXE4B Battery Tools, p. 92
 HX23 Pneumatic Tool, p. 94

HX3 TOOL SERIES OPTIONS FOR X-DIES

HX3 Hand Tools, p. 90 & 91

DMC does not provide connectors, contacts or wiring components. Parts shown here are for reference only. See disclaimer of liability on page 27.



Similar Terminal Shown

M7928/1-47 to -55, Size 14

TYPE: Class 1 Insulated Terminals, Insulation Restricting

INSULATION: Nylon, UL 94V-2

TERMINAL BODY & SLEEVE: Copper, ASTM B-152

PLATING: Nickel, QQ-N-290, or Tin, ASTM B-545

MAX TEMP RATING: 105° C

Tool Selection Guide

TERMINAL SPECS					DMC TOOL/DIE OPTIONS					
AWG	WIRE SIZE (MM)	INSULATION DIAMETER IN. (MM)	SLEEVE COLOR	TERMINAL/SPLICE PART NUMBER	HX3 SERIES DIE MIL-APPROVED	HX4 SERIES DIE MIL-APPROVED (MULTI-CAVITY)	HX4 SERIES MIL-APPROVED (SINGLE CAVITY)	HX4 SERIES DIE (SINGLE CAVITY)	M22520/40-01 TOOL MIL-APPROVED	
#14	2.15	.078-.130 (1.98-3.30)	Blue w/ Green Stripe	M7928/1-	47	X511	Y501	Y1116*	Y671	AMT4001
					48	X511	Y501	Y1116*	Y671	AMT4001
					49	X511	Y501	Y1116*	Y671	AMT4001
					50	X511	Y501	Y1116*	Y671	AMT4001
					51	X511	Y501	Y1116*	Y671	AMT4001
					52	X511	Y501	Y1116*	Y671	AMT4001
					53	X511	Y501	Y1116*	Y671	AMT4001
					54	X511	Y501	Y1116*	Y671	AMT4001
					55	X511	Y501	Y1116*	Y671	AMT4001

*QPL in progress, die set includes insulation adjustment feature

Terminal Manufacturers' Part Numbers

TERMINAL SPECS			TERMINAL MANUFACTURERS' TERMINAL #						
AWG	SLEEVE COLOR	TERMINAL/SPLICE PART NUMBER	BURNDY	HOLLINGSWORTH	MOLEX	PANDUIT	THOMAS&BETTS	TYCO ELEC	
#14	Blue w/ Green Stripe	M7928/1-	47	--	--	--	--	--	52274-1
			48	--	--	--	--	--	2-320561-4
			49	--	--	--	--	--	51864-8
			50	--	--	--	--	--	1-51864-1
			51	--	--	--	--	--	51864-9
			52	--	--	--	--	--	2-320563-4
			53	--	--	--	--	--	2-320575-3
			54	--	--	--	--	--	2-320564-2
			55	--	--	--	--	--	2-328976-2

NOTE: Component manufactures' and OEM instructions shall take precedence over the information presented in these charts. Wire ranges are for reference only.

HX4 TOOL SERIES OPTIONS FOR Y-DIES

HX4 Hand Tools, p. 90 & 91
 HXE4B Battery Tools, p. 92
 HX23 Pneumatic Tool, p. 94

HX3 TOOL SERIES OPTIONS FOR X-DIES

HX3 Hand Tools, p. 90 & 91

DMC does not provide connectors, contacts or wiring components. Parts shown here are for reference only. See disclaimer of liability on page 27.



Similar Terminal Shown

M7928/1-56 to -62, Size 12

TYPE: Class 1 Insulated Terminals, Insulation Restricting

INSULATION: Nylon, UL 94V-2

TERMINAL BODY & SLEEVE: Copper, ASTM B-152

PLATING: Nickel, QQ-N-290, or Tin, ASTM B-545

MAX TEMP RATING: 105° C

Tool Selection Guide

TERMINAL SPECS					DMC TOOL/DIE OPTIONS				
AWG	WIRE SIZE (MM)	INSULATION DIAMETER IN. (MM)	SLEEVE COLOR	TERMINAL/SPICE PART NUMBER	HX3 SERIES DIE MIL-APPROVED	HX4 SERIES DIE MIL-APPROVED (MULTI-CAVITY)	HX4 SERIES DIE MIL-APPROVED (SINGLE CAVITY)	HX4 SERIES DIE (SINGLE CAVITY)	
#12	3.37	.095-.200 (2.41-5.08)	Yellow w/ Yellow Stripe	M7928/1-	56	X515	Y501	Y1117*	Y670
					57	X515	Y501	Y1117*	Y670
					58	X515	Y501	Y1117*	Y670
					59	X515	Y501	Y1117*	Y670
					60	X515	Y501	Y1117*	Y670
					61	X515	Y501	Y1117*	Y670
					62	X515	Y501	Y1117*	Y670

*QPL in progress, die set includes insulation adjustment feature

Terminal Manufacturers' Part Numbers

TERMINAL SPECS			TERMINAL MANUFACTURERS' TERMINAL #						
AWG	SLEEVE COLOR	TERMINAL/SPICE PART NUMBER	BURNDY	HOLLINGSWORTH	MOLEX	PANDUIT	THOMAS&BETTS	TYCO ELEC	
#12	Yellow w/ Yellow Stripe	M7928/1-	56	--	--	--	--	--	2-36161-5
			57	--	--	--	--	--	2-320568-2
			58	--	--	--	--	--	2-36161-3
			59	--	--	--	--	--	2-320569-5
			60	--	--	--	--	--	2-320576-2
			61	--	--	--	--	--	2-320577-1
			62	--	--	--	--	--	--

NOTE: Component manufactures' and OEM instructions shall take precedence over the information presented in these charts. Wire ranges are for reference only.

HX4 TOOL SERIES OPTIONS FOR Y-DIES

HX4 Hand Tools, p. 90 & 91
 HXE4B Battery Tools, p. 92
 HX23 Pneumatic Tool, p. 94

HX3 TOOL SERIES OPTIONS FOR X-DIES

HX3 Hand Tools, p. 90 & 91

DMC does not provide connectors, contacts or wiring components. Parts shown here are for reference only. See disclaimer of liability on page 27.



Similar Terminal Shown

M7928/1-63 to -69, Size 10

TYPE: Class 1 Insulated Terminals, Insulation Restricting

INSULATION: Nylon, UL 94V-2

TERMINAL BODY & SLEEVE: Copper, ASTM B-152

PLATING: Nickel, QQ-N-290, or Tin, ASTM B-545

MAX TEMP RATING: 105° C

Tool Selection Guide

TERMINAL SPECS					DMC TOOL/DIE OPTIONS				
AWG	WIRE SIZE (MM)	INSULATION DIAMETER IN. (MM)	SLEEVE COLOR	TERMINAL/SPLICE PART NUMBER	HX3 SERIES DIE MIL-APPROVED	HX4 SERIES DIE MIL-APPROVED (MULTI-CAVITY)	HX4 SERIES DIE MIL-APPROVED (SINGLE CAVITY)	HX4 SERIES DIE (SINGLE CAVITY)	
#10	6.11	.119-.200 (3.02-5.08)	Yellow w/ Brown Stripe)	M7928/1-	63	X515	Y501	Y1117*	Y670
					64	X515	Y501	Y1117*	Y670
					65	X515	Y501	Y1117*	Y670
					66	X515	Y501	Y1117*	Y670
					67	X515	Y501	Y1117*	Y670
					68	X515	Y501	Y1117*	Y670
					69	X515	Y501	Y1117*	Y670

*QPL in progress, die set includes insulation adjustment feature

Terminal Manufacturers' Part Numbers

TERMINAL SPECS			TERMINAL MANUFACTURERS' TERMINAL #						
AWG	SLEEVE COLOR	TERMINAL/SPLICE PART NUMBER	BURNDY	HOLLINGSWORTH	MOLEX	PANDUIT	THOMAS&BETTS	TYCO ELEC	
#10	Yellow w/ Brown Stripe)	M7928/1-	63	--	--	--	--	--	2-36161-6
			64	--	--	--	--	--	2-320568-3
			65	--	--	--	--	--	2-36161-4
			66	--	--	--	--	--	2-320569-6
			67	--	--	--	--	--	2-320576-3
			68	--	--	--	--	--	2-320577-2
			69	--	--	--	--	--	--

NOTE: Component manufactures' and OEM instructions shall take precedence over the information presented in these charts. Wire ranges are for reference only.

HX4 TOOL SERIES OPTIONS FOR Y-DIES

HX4 Hand Tools, p. 90 & 91
 HXE4B Battery Tools, p. 92
 HX23 Pneumatic Tool, p. 94

HX3 TOOL SERIES OPTIONS FOR X-DIES

HX3 Hand Tools, p. 90 & 91

DMC does not provide connectors, contacts or wiring components. Parts shown here are for reference only. See disclaimer of liability on page 27.



Similar Terminal Shown

M7928/4-101 to -110, Sizes 22 to 14

TYPE: Class 1 Insulated Terminals, Radiation Resistant

INSULATION: Polyvinylidene Fluoride (PVF2)

TERMINAL BODY & SLEEVE: Copper, ASTM B-152

PLATING: Tin, ASTM B-545

MAX TEMP RATING: 150° C

Tool Selection Guide

TERMINAL SPECS					DMC TOOL/DIE OPTIONS					
AWG	WIRE SIZE (MM)	INSULATION DIAMETER IN. (MM)	SLEEVE COLOR	TERMINAL/SPICE PART NUMBER	HX3 SERIES DIE MIL-APPROVED	HX4 SERIES DIE MIL-APPROVED (MULTI-CAVITY)	HX4 SERIES DIE MIL-APPROVED (SINGLE CAVITY)	HX4 SERIES DIE (SINGLE CAVITY)	M22520/40-01 TOOL MIL-APPROVED	
#22-18	0.26-0.96	.140 (3.56)	Red	M7928/4-	101	X511	Y501	Y1115*	Y672	AMT4001
					102	X511	Y501	Y1115*	Y672	AMT4001
					103	X511	Y501	Y1115*	Y672	AMT4001
					104	X511	Y501	Y1115*	Y672	AMT4001
					105	X511	Y501	Y1115*	Y672	AMT4001
#16-14	1.04 - 2.62	.170 (4.32)	Blue	M7928/4-	106	X511	Y501	Y1116*	Y671	AMT4001
					107	X511	Y501	Y1116*	Y671	AMT4001
					108	X511	Y501	Y1116*	Y671	AMT4001
					109	X511	Y501	Y1116*	Y671	AMT4001
					110	X511	Y501	Y1116*	Y671	AMT4001

*QPL in progress, die set includes insulation adjustment feature

Terminal Manufacturers' Part Numbers

TERMINAL SPECS			TERMINAL MANUFACTURERS' TERMINAL #						
AWG	SLEEVE COLOR	TERMINAL/SPICE PART NUMBER	BURNDY	HOLLINGSWORTH	MOLEX	PANDUIT	THOMAS&BETTS	TYCO ELEC	
#22-18	Red	M7928/4-	101	--	--	--	--	--	53406-1
			102	--	--	--	--	--	53407-1
			103	--	--	--	--	--	53409-1
			104	--	--	--	--	--	53411-1
			105	--	--	--	--	--	53412-1
#16-14	Blue	M7928/4-	106	--	--	--	--	--	53415-1
			107	--	--	--	--	--	53416-1
			108	--	--	--	--	--	53418-1
			109	--	--	--	--	--	53420-1
			110	--	--	--	--	--	53421-1

NOTE: Component manufactures' and OEM instructions shall take precedence over the information presented in these charts. Wire ranges are for reference only.

HX4 TOOL SERIES OPTIONS FOR Y-DIES

HX4 Hand Tools, p. 90 & 91
 HXE4B Battery Tools, p. 92
 HX23 Pneumatic Tool, p. 94

HX3 TOOL SERIES OPTIONS FOR X-DIES

HX3 Hand Tools, p. 90 & 91

DMC does not provide connectors, contacts or wiring components. Parts shown here are for reference only. See disclaimer of liability on page 27.



Similar Terminal Shown

M7928/4-111 to -114, Sizes 12 to 10

TYPE: Class 1 Insulated Terminals, Radiation Resistant

INSULATION: Polyvinylidene Flouride (PVF2)

TERMINAL BODY & SLEEVE: Copper, ASTM B-152

PLATING: Tin, ASTM B-545

MAX TEMP RATING: 150° C

Tool Selection Guide

TERMINAL SPECS					DMC TOOL/DIE OPTIONS				
AWG	WIRE SIZE (MM)	INSULATION DIAMETER IN. (MM)	SLEEVE COLOR	TERMINAL/SPLICE PART NUMBER	HX3 SERIES DIE MIL-APPROVED	HX4 SERIES DIE MIL-APPROVED (MULTI-CAVITY)	HX4 SERIES DIE MIL-APPROVED (SINGLE CAVITY)	HX4 SERIES DIE (SINGLE CAVITY)	
#12-10	2.62 - 6.64	.230 (5.84)	Yellow	M7928/4-	111	X515	Y501	Y1117*	Y670
					112	X515	Y501	Y1117*	Y670
					113	X515	Y501	Y1117*	Y670
					114	X515	Y501	Y1117*	Y670

*QPL in progress, die set includes insulation adjustment feature

Terminal Manufacturers' Part Numbers

TERMINAL SPECS			TERMINAL MANUFACTURERS' TERMINAL #						
AWG	SLEEVE COLOR	TERMINAL/SPLICE PART NUMBER	BURNDY	HOLLINGSWORTH	MOLEX	PANDUIT	THOMAS & BETTS	TYCO ELEC	
#12-10	Yellow	M7928/4-	111	--	--	--	--	--	53423-1
			112	--	--	--	--	--	53425-1
			113	--	--	--	--	--	53427-1
			114	--	--	--	--	--	53428-1

NOTE: Component manufactures' and OEM instructions shall take precedence over the information presented in these charts. Wire ranges are for reference only.

HX4 TOOL SERIES OPTIONS FOR Y-DIES

HX4 Hand Tools, p. 90 & 91
 HXE4B Battery Tools, p. 92
 HX23 Pneumatic Tool, p. 94

HX3 TOOL SERIES OPTIONS FOR X-DIES

HX3 Hand Tools, p. 90 & 91

DMC does NOT provide connectors, contacts, or wiring components. Parts are shown here for reference only. See disclaimer of liability on page 27.



Similar Terminal Shown

M7928/4-143 to -151, Sizes 26 to 18

TYPE: Class 1 Insulated Terminals, Radiation Resistant

INSULATION: Polyvinylidene Fluoride (PVF2)

TERMINAL BODY & SLEEVE: Copper, ASTM B-152

PLATING: Tin, ASTM B-545

MAX TEMP RATING: 150° C

Tool Selection Guide

TERMINAL SPECS					DMC TOOL/DIE OPTIONS					
AWG	WIRE SIZE (MM)	INSULATION DIAMETER IN. (MM)	SLEEVE COLOR	TERMINAL/SPLICE PART NUMBER	HX3 SERIES DIE MIL-APPROVED	HX4 SERIES DIE MIL-APPROVED (MULTI-CAVITY)	HX4 SERIES DIE MIL-APPROVED (SINGLE CAVITY)	HX4 SERIES DIE (SINGLE CAVITY)	M22520/40-01 TOOL MIL-APPROVED	
#26-24	0.10 - 0.26	.082 (2.09)	Yellow	M7928/4-	143	X511	Y501	Y1115*	Y672	--
					144	X511	Y501	Y1115*	Y672	--
					145	X511	Y501	Y1115*	Y672	--
					146	X511	Y501	Y1115*	Y672	--
					147	X511	Y501	Y1115*	Y672	--
#22-18	0.26- 0.96	.125 (3.18)	Red	M7928/4-	148	X511	Y501	Y1115*	Y672	AMT4001
					149	X511	Y501	Y1115*	Y672	AMT4001
					150	X511	Y501	Y1115*	Y672	AMT4001
					151	X511	Y501	Y1115*	Y672	AMT4001

*QPL in progress, die set includes insulation adjustment feature

Terminal Manufacturers' Part Numbers

TERMINAL SPECS			TERMINAL MANUFACTURERS' TERMINAL #						
AWG	SLEEVE COLOR	TERMINAL/SPLICE PART NUMBER	BURNDY	HOLLINGSWORTH	MOLEX	PANDUIT	THOMAS & BETTS	TYCO ELEC	
#26-24	Yellow	M7928/4-	143	--	--	--	--	--	53400-1
			144	--	--	--	--	--	53401-1
			145	--	--	--	--	--	53402-1
			146	--	--	--	--	--	53403-1
			147	--	--	--	--	--	53404-1
#22-18	Red	M7928/4-	148	--	--	--	--	--	53405-1
			149	--	--	--	--	--	53408-1
			150	--	--	--	--	--	53410-1
			151	--	--	--	--	--	53413-1

NOTE: Component manufactures' and OEM instructions shall take precedence over the information presented in these charts. Wire ranges are for reference only.

HX4 TOOL SERIES OPTIONS FOR Y-DIES

HX4 Hand Tools, p. 90 & 91
 HXE4B Battery Tools, p. 92
 HX23 Pneumatic Tool, p. 94

HX3 TOOL SERIES OPTIONS FOR X-DIES

HX3 Hand Tools, p. 90 & 91

DMC does NOT provide connectors, contacts, or wiring components. Parts are shown here for reference only. See disclaimer of liability on page 27.



Similar Terminal Shown

M7928/4-152 TO -159, SIZES 16 TO 10

TYPE: Class 1 Insulated Terminals, Radiation Resistant

INSULATION: Polyvinylidene Flouride (PVF2)

TERMINAL BODY & SLEEVE: Copper, ASTM B-152

PLATING: Tin, ASTM B-545

MAX TEMP RATING: 150° C

Tool Selection Guide

TERMINAL SPECS					DMC TOOL/DIE OPTIONS					
AWG	WIRE SIZE (MM)	INSULATION DIAMETER IN. (MM)	SLEEVE COLOR	TERMINAL/SPLICE PART NUMBER	HX3 SERIES DIE MIL-APPROVED	HX4 SERIES DIE MIL-APPROVED (MULTI-CAVITY)	HX4 SERIES DIE MIL-APPROVED (SINGLE CAVITY)	HX4 SERIES DIE (SINGLE CAVITY)	M22520/40-01 TOOL MIL-APPROVED	
#16-14	1.04 - 2.62	.150 (3.81)	Blue	M7928/4-	152	X515	Y501	Y1116*	Y671	AMT4001
					153	X515	Y501	Y1116*	Y671	AMT4001
					154	X515	Y501	Y1116*	Y671	AMT4001
					155	X515	Y501	Y1116*	Y671	AMT4001
#12-10	2.62 - 6.64	.230 (5.84)	Yellow	M7928/4-	156	X515	Y501	Y1117*	Y670	--
					157	X515	Y501	Y1117*	Y670	--
					158	X515	Y501	Y1117*	Y670	--
					159	X515	Y501	Y1117*	Y670	--

*QPL in progress, die set includes insulation adjustment feature

Terminal Manufacturers' Part Numbers

TERMINAL SPECS			TERMINAL MANUFACTURERS' TERMINAL #						
AWG	SLEEVE COLOR	TERMINAL/SPLICE PART NUMBER	BURNDY	HOLLINGSWORTH	MOLEX	PANDUIT	THOMAS & BETTS	TYCO ELEC	
#16-14	Blue	M7928/4-	152	--	--	--	--	--	53414-1
			153	--	--	--	--	--	53417-1
			154	--	--	--	--	--	53419-1
			155	--	--	--	--	--	53422-1
#12-10	Yellow	M7928/4-	156	--	--	--	--	--	53424-1
			157	--	--	--	--	--	53426-1
			158	--	--	--	--	--	--
			159	--	--	--	--	--	--

NOTE: Component manufactures' and OEM instructions shall take precedence over the information presented in these charts. Wire ranges are for reference only.

HX4 TOOL SERIES OPTIONS FOR Y-DIES

HX4 Hand Tools, p. 90 & 91
 HXE4B Battery Tools, p. 92
 HX23 Pneumatic Tool, p. 94

HX3 TOOL SERIES OPTIONS FOR X-DIES

HX3 Hand Tools, p. 90 & 91

DMC does NOT provide connectors, contacts, or wiring components. Parts are shown here for reference only. See disclaimer of liability on page 27.



Similar Splice Shown

M7928/5-1 TO -5, SIZES 26 TO 10

TYPE: Class 1 Insulated Splices

INSULATION: Nylon, UL 94V-2

TERMINAL BODY & SLEEVE: Copper, ASTM B-152

PLATING: Nickel, QQ-N-290, or Tin, ASTM B-545

MAX TEMP RATING: 105° C

Tool Selection Guide

SPLICE SPECS						DMC TOOL/DIE OPTIONS
AWG	WIRE SIZE (MM)	INSULATION DIAMETER IN. (MM)	SLEEVE COLOR	TERMINAL/SPLICE PART NUMBER		HX4 SERIES DIE MIL-APPROVED
#26-24	0.12-0.24	.082 (2.08)	Yellow	M7928/5-	1	Y527
#24 -20	0.16-0.65	.100 (2.54)	Natural	M7928/5-	2	Y527
#22-18	0.26-0.96	.125 (3.18)	Red	M7928/5-	3	Y501
#16-14	1.04-2.62	.150 (3.81)	Blue	M7928/5-	4	Y501
#12-10	2.62-6.64	.220 (5.59)	Yellow	M7928/5-	5	Y501

Splice Manufacturers' Part Numbers

SPLICE SPECS				SPLICE MANUFACTURERS' SPLICE #					
AWG	SLEEVE COLOR	TERMINAL/SPLICE PART NUMBER		BURNDY	HOLLINGSWORTH	MOLEX	PANDUIT	THOMAS & BETTS	TYCO ELEC (RAYCHEM)
#26-24	Yellow	M7928/5-	1	--	--	--	--	--	323994
#24 -20	Natural	M7928/5-	2	--	--	--	--	--	323975
#22-18	Red	M7928/5-	3	--	B18 70BN	WA-840	--	--	320559
#16-14	Blue	M7928/5-	4	--	B18 71BN	WB-841	--	--	320562
#12-10	Yellow	M7928/5-	5	--	B18 72BN	WC-842	--	--	320570

NOTE: Component manufactures' and OEM instructions shall take precedence over the information presented in these charts. Wire ranges are for reference only.

HX4 TOOL SERIES OPTIONS FOR Y-DIES

HX4 Hand Tools, p. 90 & 91

HXE4B Battery Tools, p. 92

HX23 Pneumatic Tool, p. 94

DMC does NOT provide connectors, contacts, or wiring components. Parts are shown here for reference only. See disclaimer of liability on page 27.



Similar Splice Shown

M7928/6-1 TO -5, SIZES 26 TO 10

TYPE: Class 1 Insulated Splices, Radiation Resistant

INSULATION: Polyvinylidene Fluoride (PVF2) [Natural Color]

SPLICE BODY & SLEEVE: Copper, ASTM B-152

PLATING: Tin, ASTM B-545

MAX TEMP RATING: 105° C

Tool Selection Guide

SPLICE SPECS						DMC TOOL/DIE OPTIONS
AWG	WIRE SIZE (MM)	INSULATION DIAMETER IN. (MM)	SLEEVE COLOR	TERMINAL/SPLICE PART NUMBER		HX4 SERIES DIE MIL-APPROVED
#26-24	0.12-0.24	.082 (2.08)	Yellow Stripe	M7928/6-	1	Y527
#24 -20	0.16-0.65	.100 (2.54)	White Stripe	M7928/6-	2	Y527
#22-18	0.26-0.96	.125 (3.18)	Red Stripe	M7928/6-	3	Y501
#16-14	1.04-2.62	.150 (3.81)	Blue Stripe	M7928/6-	4	Y501
#12-10	2.62-6.64	.220 (5.59)	Yellow Stripe	M7928/6-	5	Y501

Splice Manufacturers' Part Numbers

SPLICE SPECS				SPLICE MANUFACTURERS' SPLICE #					
AWG	SLEEVE COLOR	TERMINAL/SPLICE PART NUMBER		BURNDY	HOLLINGSWORTH	MOLEX	PANDUIT	THOMAS & BETTS	TYCO ELEC (RAYCHEM)
#26-24	Yellow Stripe	M7928/6-	1	--	--	--	--	--	53546-1
#24 -20	White Stripe	M7928/6-	2	--	--	--	--	--	53547-1
#22-18	Red Stripe	M7928/6-	3	--	--	--	--	--	53548-1
#16-14	Blue Stripe	M7928/6-	4	--	--	--	--	--	53549-1
#12-10	Yellow Stripe	M7928/6-	5	--	--	--	--	--	53550-1

NOTE: Component manufactures' instructions shall take precedence over the information presented in these charts. Wire ranges are for reference only.

HX4 TOOL SERIES OPTIONS FOR Y-DIES

HX4 Hand Tools, p. 90 & 91

HXE4B Battery Tools, p. 92

HX23 Pneumatic Tool, p. 94

DMC does NOT provide connectors, contacts, or wiring components. Parts are shown here for reference only. See disclaimer of liability on page 27.



Similar Terminal Shown

M7928/7-1 TO -11, SIZES 22 TO 14

TYPE: Class 1 Uninsulated Terminals, Ring Tongue

INSULATION: N/A

TERMINAL BODY & SLEEVE: Copper, ASTM B-152

PLATING: Tin, ASTM B-545

MAX TEMP RATING: 175° C

Tool Selection Guide

TERMINAL SPECS					DMC TOOL/DIE OPTIONS				
AWG	WIRE SIZE (MM)	INSULATION DIAMETER IN. (MM)	SLEEVE COLOR	TERMINAL/SPLICE PART NUMBER	HX4 SERIES DIE (1 INDENT)	HX4 SERIES DIE (2 INDENT)	GMT SERIES TOOL (1 INDENT)	GMT SERIES TOOL (2 INDENT)	
#22-18	0.26-0.96	N/A	N/A	M7928/7-	1	Y554	Y788	GMT277	GMT1005
					2	Y554	Y788	GMT277	GMT1005
					3	Y554	Y788	GMT277	GMT1005
					4	Y554	Y788	GMT277	GMT1005
					5	Y554	Y788	GMT277	GMT1005
					6	Y554	Y788	GMT277	GMT1005
#16-14	1.04 - 2.62	N/A	N/A	M7928/7-	7	Y554	Y788	GMT277	GMT1005
					8	Y554	Y788	GMT277	GMT1005
					9	Y554	Y788	GMT277	GMT1005
					10	Y554	Y788	GMT277	GMT1005
					11	Y554	Y788	GMT277	GMT1005

Terminal Manufacturers' Part Numbers

TERMINAL SPECS			TERMINAL MANUFACTURERS' TERMINAL #						
AWG	SLEEVE COLOR	TERMINAL/SPLICE PART NUMBER	BURNDY	HOLLINGSWORTH	MOLEX	PANDUIT	THOMAS & BETTS	TYCO ELEC	
#22-18	N/A	M7928/7-	1	--	R4103B	--	--	--	--
			2	--	R4104B	--	--	--	--
			3	--	R4262B	--	--	--	--
			4	--	R4264B	--	--	--	--
			5	--	R4114B	--	--	--	--
			6	--	R4115B	--	--	--	--
#16-14	N/A	M7928/7-	7	--	R4121B	--	--	--	--
			8	--	R4123B	--	--	--	320093
			9	--	R4125B	--	--	--	--
			10	--	R4126B	--	--	--	--
			11	--	R4119B	--	--	--	--

NOTE: Component manufactures' and OEM instructions shall take precedence over the information presented in these charts. Wire ranges are for reference only.

GMT TOOL SERIES OPTIONS

PMTxxx Pneumatic Tool, p. 101
 GMTxxx Hand Tool, p. 98 & 99
 GMTExxx Battery Tool, p. 100

HX4 TOOL SERIES OPTIONS FOR Y-DIES

HX4 Hand Tools, p. 90 & 91
 HXE4B Battery Tools, p. 92
 HX23 Pneumatic Tool, p. 94

DCT TOOL SERIES OPTIONS

DCT4 Hand Tool, p. 90-91
 EMC3300 Battery Tool, p. 89

DMC does NOT provide connectors, contacts, or wiring components. Parts are shown here for reference only. See disclaimer of liability on page 27.



Similar Terminal Shown

M7928/13-101 TO -110, SIZES 22 TO 14

TYPE: Class 1 Insulated Terminals, Radiation & Tin Whisker Resistent

INSULATION: Polyvinylidene Fluoride (PVF2)

TERMINAL BODY & SLEEVE: Copper, ASTM B-152

PLATING: Tin, ASTM B-545, Alloyed with 3% by Weight, Minimum Lead

MAX TEMP RATING: 105° C

Tool Selection Guide

TERMINAL SPECS					DMC TOOL/DIE OPTIONS			
AWG	WIRE SIZE (MM)	INSULATION DIAMETER IN. (MM)	SLEEVE COLOR	TERMINAL/SPLICE PART NUMBER	HX4 SERIES DIE MIL-APPROVED (MULTI-CAVITY)	HX4 SERIES DIE MIL-APPROVED (SINGLE CAVITY)	M22520/40-01 TOOL MIL-APPROVED	
#22-18	0.26-0.96	--	Red	M7928/13-	101	Y501	Y1115*	AMT4001
					102	Y501	Y1115*	AMT4001
					103	Y501	Y1115*	AMT4001
					104	Y501	Y1115*	AMT4001
					105	Y501	Y1115*	AMT4001
#16-14	1.04 - 2.62	--	Blue	M7928/13-	106	Y501	Y1116*	AMT4001
					107	Y501	Y1116*	AMT4001
					108	Y501	Y1116*	AMT4001
					109	Y501	Y1116*	AMT4001
					110	Y501	Y1116*	AMT4001

*QPL in progress, die set includes insulation adjustment feature

Terminal Manufacturers' Part Numbers

TERMINAL SPECS			TERMINAL MANUFACTURERS' TERMINAL #						
AWG	SLEEVE COLOR	TERMINAL/SPLICE PART NUMBER	BURNDY	HOLLINGSWORTH	MOLEX	PANDUIT	THOMAS & BETTS	TYCO ELEC	
#22-18	Red	M7928/13-	101	--	--	--	--	--	53406-1
			102	--	--	--	--	--	53407-1
			103	--	--	--	--	--	53409-1
			104	--	--	--	--	--	53411-1
			105	--	--	--	--	--	53412-1
#16-14	Blue	M7928/13-	106	--	--	--	--	--	53415-1
			107	--	--	--	--	--	53416-1
			108	--	--	--	--	--	53418-1
			109	--	--	--	--	--	53420-1
			110	--	--	--	--	--	53421-1

NOTE: Component manufactures' and OEM instructions shall take precedence over the information presented in these charts. Wire ranges are for reference only.

HX4 TOOL SERIES OPTIONS FOR Y-DIES

HX4 Hand Tools, p. 90 & 91
 HXE4B Battery Tools, p. 92
 HX23 Pneumatic Tool, p. 94

HX3 TOOL SERIES OPTIONS FOR X-DIES

HX3 Hand Tools, p. 90 & 91

DMC does NOT provide connectors, contacts, or wiring components. Parts are shown here for reference only. See disclaimer of liability on page 27.



Similar Terminal Shown

M7928/13-111 TO -114, SIZES 12 TO 10

TYPE: Class 1 Insulated Terminals, Radiation Resistent & Tin Whisker Resistent
INSULATION: Polyvinylidene Fluoride (PVF2)
TERMINAL BODY & SLEEVE: Copper, ASTM B-152
PLATING: Tin, ASTM B-545, Alloyed with 3% by Weight, Minimum Lead
MAX TEMP RATING: 105° C

Tool Selection Guide

TERMINAL SPECS					DMC TOOL/DIE OPTIONS				
AWG	WIRE SIZE (MM)	INSULATION DIAMETER IN. (MM)	SLEEVE COLOR	TERMINAL/SPLICE PART NUMBER	HX3 SERIES DIE MIL-APPROVED	HX4 SERIES DIE MIL-APPROVED (MULTI-CAVITY)	HX4 SERIES DIE MIL-APPROVED (SINGLE CAVITY)	HX4 SERIES DIE (SINGLE CAVITY)	
#12-10	2.62-6.64	--	Yellow	M7928/13-	111	X515	Y501	Y1117*	Y670
					112	X515	Y501	Y1117*	Y670
					113	X515	Y501	Y1117*	Y670
					114	X515	Y501	Y1117*	Y670

*QPL in Progress, Die set includes insulation adjustment feature.

Terminal Manufacturers' Part Numbers

TERMINAL SPECS			TERMINAL MANUFACTURERS' TERMINAL #						
AWG	SLEEVE COLOR	TERMINAL/SPLICE PART NUMBER	BURNDY	HOLLINGSWORTH	MOLEX	PANDUIT	THOMAS & BETTS	TYCO ELEC	
#12-10	Yellow	M7928/13-	111	--	--	--	--	--	53423-1
			112	--	--	--	--	--	53425-1
			113	--	--	--	--	--	53427-1
			114	--	--	--	--	--	53428-1

NOTE: Component manufactures' and OEM instructions shall take precedence over the information presented in these charts. Wire ranges are for reference only.

HX4 TOOL SERIES OPTIONS FOR Y-DIES

HX4 Hand Tools, p. 90 & 91
 HXE4B Battery Tools, p. 92
 HX23 Pneumatic Tool, p. 94

HX3 TOOL SERIES OPTIONS FOR X-DIES

HX3 Hand Tools, p. 90 & 91

DMC does NOT provide connectors, contacts, or wiring components. Parts are shown here for reference only. See disclaimer of liability on page 27.



Similar Terminal Shown

M7928/13-143 TO -151, SIZES 26 TO 18

TYPE: Class 1 Insulated Terminals, Radiation Resistent & Tin Whisker Resistent

INSULATION: Polyvinylidene Fluoride (PVF2)

TERMINAL BODY & SLEEVE: Copper, ASTM B-152

PLATING: Tin, ASTM B-545, Alloyed with 3% by Weight, Minimum Lead

MAX TEMP RATING: 105° C

Tool Selection Guide

TERMINAL SPECS					DMC TOOL/DIE OPTIONS					
AWG	WIRE SIZE (MM)	INSULATION DIAMETER IN. (MM)	SLEEVE COLOR	TERMINAL/SPLICE PART NUMBER	HX3 SERIES DIE MIL-APPROVED	HX4 SERIES DIE MIL-APPROVED (MULTI-CAVITY)	HX4 SERIES DIE MIL-APPROVED (SINGLE CAVITY)	HX4 SERIES DIE (SINGLE CAVITY)	M22520/40-01 TOOL MIL-APPROVED	
#26-24	0.10-0.26	--	Yellow	M7928/13	143	X511	Y501	Y1115*	Y672	AMT4001
					144	X511	Y501	Y1115*	Y672	AMT4001
					145	X511	Y501	Y1115*	Y672	AMT4001
					146	X511	Y501	Y1115*	Y672	AMT4001
					147	X511	Y501	Y1115*	Y672	AMT4001
#22-18	0.26-0.96	--	Red	M7928/13	148	X511	Y501	Y1115*	Y672	AMT4001
					149	X511	Y501	Y1115*	Y672	AMT4001
					150	X511	Y501	Y1115*	Y672	AMT4001
					151	X511	Y501	Y1115*	Y672	AMT4001

*QPL in progress, die set includes insulation adjustment feature

Terminal Manufacturers' Part Numbers

TERMINAL SPECS			TERMINAL MANUFACTURERS' TERMINAL #						
AWG	SLEEVE COLOR	TERMINAL/SPLICE PART NUMBER	BURNDY	HOLLINGSWORTH	MOLEX	PANDUIT	THOMAS & BETTS	TYCO ELEC	
#26-24	Yellow	M7928/13	143	--	--	--	--	--	53400-1
			144	--	--	--	--	--	53401-1
			145	--	--	--	--	--	53402-1
			146	--	--	--	--	--	53403-1
			147	--	--	--	--	--	53404-1
#22-18	Red	M7928/13	148	--	--	--	--	--	53405-1
			149	--	--	--	--	--	53408-1
			150	--	--	--	--	--	53410-1
			151	--	--	--	--	--	53413-1

NOTE: Component manufactures' and OEM instructions shall take precedence over the information presented in these charts. Wire ranges are for reference only.

HX4 TOOL SERIES OPTIONS FOR Y-DIES

HX4 Hand Tools, p. 90 & 91
 HXE4B Battery Tools, p. 92
 HX23 Pneumatic Tool, p. 94

HX3 TOOL SERIES OPTIONS FOR X-DIES

HX3 Hand Tools, p. 90 & 91

DMC does NOT provide connectors, contacts, or wiring components. Parts are shown here for reference only. See disclaimer of liability on page 27.



Similar Terminal Shown

M7928/13-152 TO -159, SIZES 16 TO 10

TYPE: Class 1 Insulated Terminals, Radiation Resistent & Tin Whisker Resistent
INSULATION: Polyvinylidene Fluoride (PVF2)
TERMINAL BODY & SLEEVE: Copper, ASTM B-152
PLATING: Tin, ASTM B-545
MAX TEMP RATING: 105° C

Tool Selection Guide

TERMINAL SPECS					DMC TOOL/DIE OPTIONS					
AWG	WIRE SIZE (MM)	INSULATION DIAMETER IN. (MM)	SLEEVE COLOR	TERMINAL/SPLICE PART NUMBER	HX3 SERIES DIE MIL-APPROVED	HX4 SERIES DIE MIL-APPROVED (MULTI-CAVITY)	HX4 SERIES DIE MIL-APPROVED (SINGLE CAVITY)	HX4 SERIES DIE (SINGLE CAVITY)	M22520/40-01 TOOL MIL-APPROVED	
#16-14	1.04-2.62	--	Blue	M7928/13-	152	X515	Y501	Y1116*	Y671	AMT4001
					153	X515	Y501	Y1116*	Y671	AMT4001
					154	X515	Y501	Y1116*	Y671	AMT4001
					155	X515	Y501	Y1116*	Y671	AMT4001
#12-10	2.62-6.64	--	Yellow	M7928/13-	156	X515	Y501	Y1117*	Y670	--
					157	X515	Y501	Y1117*	Y670	--
					158	X515	Y501	Y1117*	Y670	--
					159	X515	Y501	Y1117*	Y670	--

*QPL in Progress, Die set includes insulation adjustment feature.

Terminal Manufacturers' Part Numbers

TERMINAL SPECS			TERMINAL MANUFACTURERS' TERMINAL #						
AWG	SLEEVE COLOR	TERMINAL/SPLICE PART NUMBER	BURNDY	HOLLINGSWORTH	MOLEX	PANDUIT	THOMAS & BETTS	TYCO ELEC	
#16-14	Blue	M7928/13-	152	--	--	--	--	--	53414-1
			153	--	--	--	--	--	53417-1
			154	--	--	--	--	--	53419-1
			155	--	--	--	--	--	53422-1
#12-10	Yellow	M7928/13-	156	--	--	--	--	--	53424-1
			157	--	--	--	--	--	53426-1
			158	--	--	--	--	--	--
			159	--	--	--	--	--	--

NOTE: Component manufactures' and OEM instructions shall take precedence over the information presented in these charts. Wire ranges are for reference only.

HX4 TOOL SERIES OPTIONS FOR Y-DIES

HX4 Hand Tools, p. 90 & 91
 HXE4B Battery Tools, p. 92
 HX23 Pneumatic Tool, p. 94

HX3 TOOL SERIES OPTIONS FOR X-DIES

HX3 Hand Tools, p. 90 & 91

DMC does NOT provide connectors, contacts, or wiring components. Parts are shown here for reference only. See disclaimer of liability on page 27.



Similar Splice Shown

M81824/1-01 TO -03, SIZES 26 TO 10

TYPE: Class 1 Insulated Splices

INSULATION: Nylon, UL 94V-2

SPLICE BODY & SLEEVE: Copper, ASTM B-152

PLATING: Nickel, QQ-N-290 or Tin, ASTM B-545

SEALING MATERIAL: Modified Thermoplastic

MAX TEMP RATING: 105° C

Tool Selection Guide

SPLICE SPECS					DMC TOOL/DIE OPTIONS				
AWG	WIRE SIZE (MM)	MULTIPLE CONDUCTORS CMA RANGE	SLEEVE COLOR	TERMINAL/ SPLICE PART NUMBER	HX3 SERIES DIE MIL-APPROVED	HX4 SERIES DIE MIL-APPROVED	HX4 SERIES DIE	GMT SERIES TOOL MIL-APPROVED	
#26-20	0.15-0.61	304 - 1510	Red	M81824/1- 01	X528	Y540	Y516	GMT232	
#20-16	0.39-1.34	779 - 2680	Blue	M81824/1- 02	X528	Y540	Y516	GMT232	
#16-12	0.95-3.37	1900 - 6755	Yellow	M81824/1- 03	X527	Y539	Y516	GMT232	

Splice Manufacturers' Part Numbers

SPLICE SPECS				SPLICE MANUFACTURERS' SPLICE #							
AWG	SLEEVE COLOR	TERMINAL/SPLICE PART NUMBER		BURNDY	HOLLINGSWORTH	MOLEX	PANDUIT	THOMAS & BETTS	GLENAIR	TYCO ELEC (RAYCHEM)	SUMITOMO
#26-20	0.15-0.61	M81824/1-	1	--	--	--	--	--	GS81824/1-1	D-436-36	H-CR-436-36
#20-16	0.39-1.34	M81824/1-	2	--	--	--	--	--	GS81824/1-2	D-436-37	H-CR-436-37
#16-12	0.95-3.37	M81824/1-	3	--	--	--	--	--	GS81824/1-3	D-436-38	H-CR-436-38

NOTE: Component manufactures' and OEM instructions shall take precedence over the information presented in these charts. Wire ranges are for reference only.

GMT TOOL SERIES OPTIONS

PMTxxx Pneumatic Tool, p. 101
 GMTxxx Hand Tool, p. 98 & 99
 GMTExxx Battery Tool, p. 100

HX4 TOOL SERIES OPTIONS FOR Y-DIES

HX4 Hand Tools, p. 90 & 91
 HXE4B Battery Tools, p. 92
 HX23 Pneumatic Tool, p. 94

HX3 TOOL SERIES OPTIONS FOR X-DIES

HX3 Hand Tools, p. 90 & 91

DMC does NOT provide connectors, contacts, or wiring components. Parts are shown here for reference only. See disclaimer of liability on page 27.



Similar Splice Shown

M81824/6-01 to -03, Sizes 26 to 12

TYPE: Class 1 Insulated Splices

INSULATION: Heat Shrinkable Polyvinylidene Flouride

SPLICE BODY & SLEEVE: Copper, ASTM B-280 or B75-68 or B152

PLATING: Tin, ASTM B-545

MAX TEMP RATING: Modified Thermoplastic

MAX TEMP RATING: 150° C

Tool Selection Guide

SPLICE SPECS					DMC TOOL/DIE OPTIONS			
AWG	WIRE SIZE (MM)	MULTIPLE CONDUCTORS CMA RANGE	SLEEVE COLOR	TERMINAL/SPLICE PART NUMBER	HX3 SERIES DIE MIL-APPROVED	HX4 SERIES DIE MIL-APPROVED	HX4 SERIES DIE	GMT SERIES TOOL MIL-APPROVED
#26-20	0.15-0.61	304 - 1510	Red	M81824/6- 01	X528	Y540	Y516	GMT232
#20-16	0.39-1.34	779 - 2680	Blue	M81824/6- 02	X528	Y540	Y516	GMT232
#16-12	0.95-3.37	1900 - 6755	Yellow	M81824/6- 03	X527	Y539	Y516	GMT232

Splice Manufacturers' Part Numbers

SPLICE SPECS				SPLICE MANUFACTURERS' SPLICE #						
AWG	SLEEVE COLOR	TERMINAL/SPLICE PART NUMBER		BURNDY	HOLLINGSWORTH	MOLEX	PANDUIT	THOMAS & BETTS	TYCO ELEC (RAYCHEM)	SUMITOMO
#26-20	Red	M81824/6-	01	--	--	--	--	--	D-436-82	--
#20-16	Blue	M81824/6-	02	--	--	--	--	--	D-436-83	--
#16-12	Yellow	M81824/6-	03	--	--	--	--	--	D-436-84	--

NOTE: Component manufactures' and OEM instructions shall take precedence over the information presented in these charts. Wire ranges are for reference only.

GMT TOOL SERIES OPTIONS

PMTxxx Pneumatic Tool, p. 101
 GMTxxx Hand Tool, p. 98 & 99
 GMTExxxB Battery Tool, p. 100

HX4 TOOL SERIES OPTIONS FOR Y-DIES

HX4 Hand Tools, p. 90 & 91
 HXE4B Battery Tools, p. 92
 HX23 Pneumatic Tool, p. 94

HX3 TOOL SERIES OPTIONS FOR X-DIES

HX3 Hand Tools, p. 90 & 91

DMC does NOT provide connectors, contacts, or wiring components. Parts are shown here for reference only. See disclaimer of liability on page 27.



Similar Splice Shown

M81824/7-01 TO -03, SIZES 26 TO 12

TYPE: Class 1 Insulated Splices

INSULATION: Heat Shrinkable Polyvinylidene Flouride

SPLICE BODY & SLEEVE: Copper, ASTM B-280 or B75-68 or B152

PLATING: Tin, ASTM B-545

SEALING MATERIAL: Modified Thermoplastic

MAX TEMP RATING: 150° C

Tool Selection Guide

SPLICE SPECS						DMC TOOL/DIE OPTIONS			
AWG	WIRE SIZE (MM)	MULTIPLE CONDUCTORS CMA RANGE	SLEEVE COLOR	TERMINAL/SPLICE PART NUMBER		HX3 SERIES DIE MIL-APPROVED	HX4 SERIES DIE MIL-APPROVED	HX4 SERIES DIE	GMT SERIES TOOL MIL-APPROVED
#26-20	0.15-0.61	304 - 1510	Red	M81824/7-	01	X528	Y540	Y516	GMT232
#20-16	0.39-1.34	779 - 2680	Blue	M81824/7-	02	X528	Y540	Y516	GMT232
#16-12	0.95-3.37	1900 - 6755	Yellow	M81824/7-	03	X527	Y539	Y516	GMT232

Splice Manufacturers' Part Numbers

SPLICE SPECS				SPLICE MANUFACTURERS' SPLICE #						
AWG	SLEEVE COLOR	TERMINAL/SPLICE PART NUMBER		BURNDY	HOLLINGSWORTH	MOLEX	PANDUIT	THOMAS & BETTS	TYCO ELEC (RAYCHEM)	SUMITOMO
#26-20	Red	M81824/7-	01	--	--	--	--	--	D-436-0110	--
#20-16	Blue	M81824/7-	02	--	--	--	--	--	D-436-52	--
#16-12	Yellow	M81824/7-	03	--	--	--	--	--	D-436-53	--

NOTE: Component manufactures' and OEM instructions shall take precedence over the information presented in these charts. Wire ranges are for reference only.

GMT TOOL SERIES OPTIONS

PMTxxx Pneumatic Tool, p. 101
 GMTxxx Hand Tool, p. 98 & 99
 GMTExxxB Battery Tool, p. 100

HX4 TOOL SERIES OPTIONS FOR Y-DIES

HX4 Hand Tools, p. 90 & 91
 HXE4B Battery Tools, p. 92
 HX23 Pneumatic Tool, p. 94

HX3 TOOL SERIES OPTIONS FOR X-DIES

HX3 Hand Tools, p. 90 & 91

DMC does NOT provide connectors, contacts, or wiring components. Parts are shown here for reference only. See disclaimer of liability on page 27.



Similar Splice Shown

M81824/8-01 TO -03, SIZES 26 TO 12

TYPE: Class 1 Insulated Splices

INSULATION: Heat Shrinkable Polyvinylidene Flouride

SPLICE BODY & SLEEVE: Copper, ASTM B-280 or B75-68 or B152

PLATING: Nickel, SAE AMS-QQ-N290

SEALING MATERIAL: Modified Thermoplastic

MAX TEMP RATING: 175° C

Tool Selection Guide

SPLICE SPECS						DMC TOOL/DIE OPTIONS			
AWG	WIRE SIZE (MM)	MULTIPLE CONDUCTORS CMA RANGE	SLEEVE COLOR	TERMINAL/SPLICE PART NUMBER		HX3 SERIES DIE MIL-APPROVED	HX4 SERIES DIE MIL-APPROVED	HX4 SERIES DIE	GMT SERIES TOOL MIL-APPROVED
#26-20	0.15-0.61	304 - 1510	Red	M81824/8-	01	X528	Y540	Y516	GMT232
#20-16	0.39-1.34	779 - 2680	Blue	M81824/8-	02	X528	Y540	Y516	GMT232
#16-12	0.95-3.37	1900 - 6755	Yellow	M81824/8-	03	X527	Y539	Y516	GMT232

Splice Manufacturers' Part Numbers

SPLICE SPECS				SPLICE MANUFACTURERS' SPLICE #						
AWG	SLEEVE COLOR	TERMINAL/SPLICE PART NUMBER		BURNDY	HOLLINGSWORTH	MOLEX	PANDUIT	THOMAS & BETTS	TYCO ELEC (RAYCHEM)	SUMITOMO
#26-20	Red	M81824/8-	01	--	--	--	--	--	D-436-85	--
#20-16	Blue	M81824/8-	02	--	--	--	--	--	D-436-86	--
#16-12	Yellow	M81824/8-	03	--	--	--	--	--	D-436-87	--

NOTE: Component manufactures' and OEM instructions shall take precedence over the information presented in these charts. Wire ranges are for reference only.

GMT TOOL SERIES OPTIONS

PMTxxx Pneumatic Tool, p. 101
 GMTxxx Hand Tool, p. 98 & 99
 GMTExxx Battery Tool, p. 100

HX4 TOOL SERIES OPTIONS FOR Y-DIES

HX4 Hand Tools, p. 90 & 91
 HXE4B Battery Tools, p. 92
 HX23 Pneumatic Tool, p. 94

HX3 TOOL SERIES OPTIONS FOR X-DIES

HX3 Hand Tools, p. 90 & 91

DMC does NOT provide connectors, contacts, or wiring components. Parts are shown here for reference only. See disclaimer of liability on page 27.



Similar Splice Shown

M81824/9-01 TO -03, SIZES 26 TO 12

TYPE: Class 1 Insulated Splices

INSULATION: Heat Shrinkable Polyvinylidene Flouride

SPLICE BODY & SLEEVE: Copper, ASTM B-280 or B75-68 or B152

PLATING: Tin, ASTM B-545

SEALING MATERIAL: Modified Thermoplastic

MAX TEMP RATING: 150° C

Tool Selection Guide

SPLICE SPECS					DMC TOOL/DIE OPTIONS				
AWG	WIRE SIZE (MM)	MULTIPLE CONDUCTORS CMA RANGE	SLEEVE COLOR	TERMINAL/SPLICE PART NUMBER	HX3 SERIES DIE MIL-APPROVED	HX4 SERIES DIE MIL-APPROVED	HX4 SERIES DIE	GMT SERIES TOOL MIL-APPROVED	
#26-20	0.15-0.61	304 - 1510	Red	M81824/9-01	X528	Y540	Y516	GMT232	
#20-16	0.39-1.34	779 - 2680	Blue	M81824/9-02	X528	Y540	Y516	GMT232	
#16-12	0.95-3.37	1900 - 6755	Yellow	M81824/9-03	X527	Y539	Y516	GMT232	

Splice Manufacturers' Part Numbers

SPLICE SPECS				SPLICE MANUFACTURERS' SPLICE #						
AWG	SLEEVE COLOR	TERMINAL/SPLICE PART NUMBER		BURNDY	HOLLINGSWORTH	MOLEX	PANDUIT	THOMAS & BETTS	TYCO ELEC (RAYCHEM)	SUMITOMO
#26-20	Red	M81824/9-01		--	--	--	--	--	D-436-0115	--
#20-16	Blue	M81824/9-02		--	--	--	--	--	D-436-42	--
#16-12	Yellow	M81824/9-03		--	--	--	--	--	D-436-43	--

NOTE: Component manufactures' and OEM instructions shall take precedence over the information presented in these charts. Wire ranges are for reference only.

GMT TOOL SERIES OPTIONS

PMTxxx Pneumatic Tool, p. 101
 GMTxxx Hand Tool, p. 98 & 99
 GMTExxxB Battery Tool, p. 100

HX4 TOOL SERIES OPTIONS FOR Y-DIES

HX4 Hand Tools, p. 90 & 91
 HXE4B Battery Tools, p. 92
 HX23 Pneumatic Tool, p. 94

HX3 TOOL SERIES OPTIONS FOR X-DIES

HX3 Hand Tools, p. 90 & 91

DMC does NOT provide connectors, contacts, or wiring components. Parts are shown here for reference only. See disclaimer of liability on page 27.



Similar Splice Shown

M81824/10-01 TO -03, SIZES 26 TO 12

TYPE: Class 1 Insulated Splices

INSULATION: Heat Shrinkable Polyvinylidene Flouride

SPLICE BODY & SLEEVE: Copper, ASTM B-280 or B75-68 or B152

PLATING: Nickel, SAE AMS-QQ-N290

SEALING MATERIAL: Modified Thermoplastic

MAX TEMP RATING: 175° C

Tool Selection Guide

SPLICE SPECS					DMC TOOL/DIE OPTIONS				
AWG	WIRE SIZE (MM)	MULTIPLE CONDUCTORS CMA RANGE	SLEEVE COLOR	TERMINAL/SPLICE PART NUMBER		HX3 SERIES DIE MIL-APPROVED	HX4 SERIES MIL-APPROVED	HX4 SERIES DIE	GMT SERIES TOOL MIL-APPROVED
#26-20	0.15-0.61	304 - 1510	Red	M81824/10-	01	X528	Y540	Y516	GMT232
#20-16	0.39-1.34	779 - 2680	Blue	M81824/10-	02	X528	Y540	Y516	GMT232
#16-12	0.95-3.37	1900 - 6755	Yellow	M81824/10-	03	X527	Y539	Y516	GMT232

Splice Manufacturers' Part Numbers

SPLICE SPECS				SPLICE MANUFACTURERS' SPLICE #						
AWG	SLEEVE COLOR	TERMINAL/SPLICE PART NUMBER		BURNDY	HOLLINGSWORTH	MOLEX	PANDUIT	THOMAS & BETTS	TYCO ELEC (RAYCHEM)	SUMITOMO
#26-20	Red	M81824/10-	01	--	--	--	--	--	D-436-88	--
#20-16	Blue	M81824/10-	02	--	--	--	--	--	D-436-89	--
#16-12	Yellow	M81824/10-	03	--	--	--	--	--	D-436-90	--

NOTE: Component manufactures' and OEM instructions shall take precedence over the information presented in these charts. Wire ranges are for reference only.

GMT TOOL SERIES OPTIONS

- PMTxxx Pneumatic Tool, p. 101
- GMTxxx Hand Tool, p. 98 & 99
- GMTExxx Battery Tool, p. 100

HX4 TOOL SERIES OPTIONS FOR Y-DIES

- HX4 Hand Tools, p. 90 & 91
- HXE4B Battery Tools, p. 92
- HX23 Pneumatic Tool, p. 94

HX3 TOOL SERIES OPTIONS FOR X-DIES

- HX3 Hand Tools, p. 90 & 91

DMC does NOT provide connectors, contacts, or wiring components. Parts are shown here for reference only. See disclaimer of liability on page 27.



Similar Splice Shown

M81824/11-01 TO -03, SIZES 26 TO 12

TYPE: Class 1 Insulated Splices

INSULATION: Heat-Shrinkable Cross-Linked Polyvinylidene Fluoride, (SAE AMS-DTL-23053/18)

SPLICE BODY & SLEEVE: Copper, ASTM B-280, B-75, or B-187

PLATING: Nickel, SAE AMS-QQ-N290

SEALING MATERIAL: Modified Thermoplastic

MAX TEMP RATING: 200° C

Tool Selection Guide

SPLICE SPECS						DMC TOOL/DIE OPTIONS			
AWG	WIRE SIZE MM	MULTIPLE CONDUCTORS CMA RANGE	SLEEVE COLOR	TERMINAL/SPLICE PART NUMBER		HX3 SERIES DIE MIL-APPROVED	HX4 SERIES DIE MIL-APPROVED	HX4 SERIES DIE	GMT SERIES TOOL MIL-APPROVED
#26-20	0.15-0.61	304 - 1510	Red	M81824/11-	01	X528	Y540	Y516	GMT232
#20-16	0.39-1.34	779 - 2680	Blue	M81824/11-	02	X528	Y540	Y516	GMT232
#16-12	0.95-3.37	1900 - 6755	Yellow	M81824/11-	03	X527	Y539	Y516	GMT232

Splice Manufacturers' Part Numbers

SPLICE SPECS				SPLICE MANUFACTURERS' SPLICE #						
AWG	SLEEVE COLOR	TERMINAL/SPLICE PART NUMBER		BURNDY	HOLLINGSWORTH	MOLEX	PANDUIT	THOMAS & BETTS	TYCO ELEC (RAYCHEM)	SUMITOMO
#26-20	Red	M81824/11-	01	--	--	--	--	--	D-200-82	--
#20-16	Blue	M81824/11-	02	--	--	--	--	--	D-200-83	--
#16-12	Yellow	M81824/11-	03	--	--	--	--	--	D-200-84	--

NOTE: Component manufactures' and OEM instructions shall take precedence over the information presented in these charts. Wire ranges are for reference only.

GMT TOOL SERIES OPTIONS

PMTxxx Pneumatic Tool, p. 101

GMTxxx Hand Tool, p. 98 & 99

GMTExxx Battery Tool, p. 100

HX4 TOOL SERIES OPTIONS FOR Y-DIES

HX4 Hand Tools, p. 90 & 91

HXE4B Battery Tools, p. 92

HX23 Pneumatic Tool, p. 94

HX3 TOOL SERIES OPTIONS FOR X-DIES

HX3 Hand Tools, p. 90 & 91

DMC does NOT provide connectors, contacts, or wiring components. Parts are shown here for reference only. See disclaimer of liability on page 27.

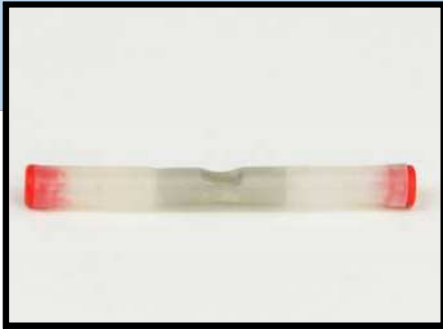

Similar Splice Shown

M81824/12-01 TO -03, SIZES 26 TO 12

TYPE: Class 1 Splice, Environment Resistant, Heatless Sealing
INSULATION: Preformed Nylon with Colored End Cap, Gel Seal
TERMINAL BODY & SLEEVE: Copper
PLATING: Tin Coated
SEALING MATERIAL: Non-Opaque Gel
MAX TEMP RATING: 150° C

Tool Selection Guide

SPLICE SPECS					DMC TOOL/DIE OPTIONS	
AWG	WIRE SIZE (MM)	MULTIPLE CONDUCTORS CMA RANGE	END CAP COLOR	TERMINAL/SPLICE PART NUMBER		GMT SERIES TOOL MIL-APPROVED
#26-20	--	--	Red	M81824/12-	01	GMT1090
#20-16	--	--	Blue	M81824/12-	02	GMT1090
#14-12	--	--	Yellow	M81824/12-	03	GMT1090

Splice Manufacturers' Part Numbers

SPLICE SPECS				SPLICE MANUFACTURERS' SPLICE #						
AWG	END CAP COLOR	TERMINAL/SPLICE PART NUMBER		BURNDY	HOLLINGSWORTH	MOLEX	PANDUIT	THOMAS & BETTS	TYCO ELEC (RAYCHEM)	SUMITOMO
#26-20	Red	M81824/12-	01	--	--	--	--	--	D-436-36-COLD	--
#20-16	Blue	M81824/12-	02	--	--	--	--	--	D-436-37-COLD	--
#14-12	Yellow	M81824/12-	03	--	--	--	--	--	D-436-38-COLD	--

NOTE: Component manufactures' and OEM instructions shall take precedence over the information presented in these charts. Wire ranges are for reference only.

GMT TOOL SERIES OPTIONS

PMTxxx Pneumatic Tool, p. 101
 GMTxxx Hand Tool, p. 98 & 99
 GMTExxxB Battery Tool, p. 100

HX4 TOOL SERIES OPTIONS FOR Y-DIES

HX4 Hand Tools, p. 90 & 91
 HXE4B Battery Tools, p. 92
 HX23 Pneumatic Tool, p. 94

DMC does NOT provide connectors, contacts, or wiring components. Parts are shown here for reference only. See disclaimer of liability on page 27.



Similar Splice Shown

M81824/14-01 TO -03, SIZES 26 TO 12

TYPE: Class 1 Splice, Environment Resistent, Heatless Sealing

INSULATION: Nylon

TERMINAL BODY & SLEEVE: Copper

PLATING: Nickel

MAX TEMP RATING: 175° C

Tool Selection Guide

SPLICE SPECS					DMC TOOL/DIE OPTIONS			
AWG	WIRE SIZE (MM)	MULTIPLE CONDUCTORS CMA RANGE	END CAP COLOR	TERMINAL/SPLICE PART NUMBER	M22520/5-01 TOOL MIL-APPROVED	HX4 SERIES DIE MIL-APPROVED	GMT SERIES TOOL MIL-APPROVED	
#26-20	--	--	Red	M81824/14-01	HX4	Y540	GMT232	
#20-16	--	--	Blue	M81824/14-02	HX4	Y540	GMT232	
#14-12	--	--	Yellow	M81824/14-03	HX4	Y539	GMT232	

Splice Manufacturers' Part Numbers

SPLICE SPECS				SPLICE MANUFACTURERS' SPLICE #						
AWG	END CAP COLOR	TERMINAL/SPLICE PART NUMBER		BURNDY	HOLLINGSWORTH	MOLEX	PANDUIT	TRI-STAR	TYCO ELEC (RAYCHEM)	SUMITOMO
#26-20	Red	M81824/14-01		--	--	--	--	H-C2015N	--	--
#20-16	Blue	M81824/14-02		--	--	--	--	H-C1615N	--	--
#14-12	Yellow	M81824/14-03		--	--	--	--	H-C1215N	--	--

NOTE: Component manufactures' and OEM instructions shall take precedence over the information presented in these charts. Wire ranges are for reference only.

GMT TOOL SERIES OPTIONS

PMTxxx Pneumatic Tool, p. 101

GMTxxx Hand Tool, p. 98 & 99

GMTExxx Battery Tool, p. 100

DMC does NOT provide connectors, contacts, or wiring components. Parts are shown here for reference only. See disclaimer of liability on page 27.



Similar Terminal Shown

MS17143-1 to -10, Sizes 22 to 10

TYPE: Class 1 Insulated Terminals, Rectangular Tongue

INSULATION: Nylon, UL 94V-2

TERMINAL BODY & SLEEVE: Copper, ASTM B-152

PLATING: Tin, ASTM B-545

MAX TEMP RATING: 105° C

Tool Selection Guide

TERMINAL SPECS					DMC TOOL/DIE OPTIONS					
AWG	WIRE SIZE (MM)	INSULATION DIAMETER IN. (MM)	SLEEVE COLOR	TERMINAL/SPLICE PART NUMBER	HX3 SERIES DIE MIL-APPROVED	HX4 SERIES DIE MIL-APPROVED (MULTI-CAVITY)	HX4 SERIES MIL-APPROVED (SINGLE CAVITY)	HX4 SERIES SINGLE CAVITY	M22520/40-01 TOOL MIL-APPROVED	
#22-18	0.26-0.96	.140 (3.56)	Red	MS 17143 1	X511	Y501	Y1115*	Y672	AMT4001	
#16-14	1.04 - 2.62	.170 (4.32)	Blue	MS 17143 2	X511	Y501	Y1116*	Y671	AMT4001	
#12-10	2.62 - 6.64	.230 (5.84)	Yellow	MS 17143 3	X515	Y501	Y1117*	Y670	--	
#22-18	0.26-0.96	.140 (3.56)	Red	MS 17143 4	X511	Y501	Y1115*	Y672	AMT4001	
#16-14	1.04 - 2.62	.170 (4.32)	Blue	MS 17143 5	X511	Y501	Y1116*	Y671	AMT4001	
#12-10	2.62 - 6.64	.230 (5.84)	Yellow	MS 17143 6	X515	Y501	Y1117*	Y670	--	
#22-18	0.26-0.96	.140 (3.56)	Red	MS 17143 7	X511	Y501	Y1115*	Y672	AMT4001	
#16-14	1.04 - 2.62	.170 (4.32)	Blue	MS 17143 8	X511	Y501	Y1116*	Y671	AMT4001	
#12-10	2.62 - 6.64	.230 (5.84)	Yellow	MS 17143 9	X515	Y501	Y1117*	Y670	--	
#22-18	0.26-0.96	.140 (3.56)	Red	MS 17143 10	X511	Y501	Y1115*	Y672	AMT4001	

*QPL in progress, die set includes insulation adjustment feature

Terminal Manufacturers' Part Numbers

TERMINAL SPECS				TERMINAL MANUFACTURERS' TERMINAL #					
AWG	SLEEVE COLOR	TERMINAL/SPLICE PART NUMBER		FCI BURNDY	HOLLINGSWORTH	MOLEX	PANDUIT	THOMAS&BETTS	TYCO ELEC
#22-18	Red	MS 17143 1		--	--	AA-880-1	--	RA 480	327932
#16-14	Blue	MS 17143 2		--	--	BB-880-2	--	RB 480	2-327934-2
#12-10	Yellow	MS 17143 3		--	--	--	--	RC 480	327936
#22-18	Red	MS 17143 4		--	--	AA-881-1	--	RA 481	2-327938-1
#16-14	Blue	MS 17143 5		--	--	BB-881-2	--	RB 481	2-327940-4
#12-10	Yellow	MS 17143 6		--	--	--	--	RC 481	327942
#22-18	Red	MS 17143 7		--	--	AA-882-1	--	RA 482	327944
#16-14	Blue	MS 17143 8		--	--	BB-882-2	--	RB 482	2-327946-4
#12-10	Yellow	MS 17143 9		--	--	--	--	RC 482	327948
#22-18	Red	MS 17143 10		--	--	AA-883-1	--	RA 483	2-327950-1

NOTE: Component manufactures' instructions shall take precedence over the information presented in these charts. Wire ranges are for reference only.

HX4 TOOL SERIES OPTIONS FOR Y-DIES

HX4 Hand Tools, p. 90 & 91
 HXE4B Battery Tools, p. 92
 HX23 Pneumatic Tool, p. 94

HX3 TOOL SERIES OPTIONS FOR X-DIES

HX3 Hand Tools, p. 90 & 91

DMC does NOT provide connectors, contacts, or wiring components. Parts are shown here for reference only. See disclaimer of liability on page 27.



Similar Terminal Shown

MS17143-11 to -21, Sizes 22 to 10

TYPE: Class 1 Insulated Terminals, Rectangular Tongue

INSULATION: Nylon, UL 94V-2

TERMINAL BODY & SLEEVE: Copper, ASTM B-152

PLATING: Tin, ASTM B-545

MAX TEMP RATING: 105° C

Tool Selection Guide

TERMINAL SPECS					DMC TOOL/DIE OPTIONS					
AWG	WIRE SIZE (MM)	INSULATION DIAMETER IN. (MM)	SLEEVE COLOR	TERMINAL/SPLICE PART NUMBER	HX3 SERIES DIE MIL-APPROVED	HX4 SERIES DIE MIL-APPROVED (MULTI-CAVITY)	HX4 SERIES DIE (SINGLE CAVITY)	HX4 SERIES DIE (SINGLE CAVITY)	M22520/40-01 TOOL MIL-APPROVED	
#16-14	1.04 - 2.62	.170 (4.32)	Blue	MS 17143	11	X511 Die	Y501	Y1116*	Y671	AMT4001
#12-10	2.62 - 6.64	.230 (5.84)	Yellow	MS 17143	12	X515 Die	Y501	Y1117*	Y670	--
#22-18	0.26-0.96	.140 (3.56)	Red	MS 17143	13	X511 Die	Y501	Y1115*	Y672	AMT4001
#16-14	1.04 - 2.62	.170 (4.32)	Blue	MS 17143	14	X511 Die	Y501	Y1116*	Y671	AMT4001
#12-10	2.62 - 6.64	.230 (5.84)	Yellow	MS 17143	15	X515 Die	Y501	Y1117*	Y670	--
#22-18	0.26-0.96	.140 (3.56)	Red	MS 17143	16	X511 Die	Y501	Y1115*	Y672	AMT4001
#16-14	1.04 - 2.62	.170 (4.32)	Blue	MS 17143	17	X511 Die	Y501	Y1116*	Y671	AMT4001
#12-10	2.62 - 6.64	.230 (5.84)	Yellow	MS 17143	18	X515 Die	Y501	Y1117*	Y670	--
#22-18	0.26-0.96	.140 (3.56)	Red	MS 17143	19	X511 Die	Y501	Y1115*	Y672	AMT4001
#16-14	1.04 - 2.62	.170 (4.32)	Blue	MS 17143	20	X511 Die	Y501	Y1116*	Y671	AMT4001
#12-10	2.62 - 6.64	.230 (5.84)	Yellow	MS 17143	21	X515 Die	Y501	Y1117*	Y670	--

*QPL in progress, die set includes insulation adjustment feature

Terminal Manufacturers' Part Numbers

TERMINAL SPECS				TERMINAL MANUFACTURERS' TERMINAL #					
AWG	SLEEVE COLOR	TERMINAL/SPLICE PART NUMBER		FCI BURNDY	HOLLINGSWORTH	MOLEX	PANDUIT	THOMAS&BETTS	TYCO ELEC
#16-14	Blue	MS 17143	11	--	--	BB-883-2	--	RB 483	2-327952-2
#12-10	Yellow	MS 17143	12	--	--	--	--	RC 483	327954
#22-18	Red	MS 17143	13	--	--	AA-884-1	--	RA 484	2-327956-1
#16-14	Blue	MS 17143	14	--	--	BB-884-2	--	RB 484	2-327958-4
#12-10	Yellow	MS 17143	15	--	--	--	--	RC 484	2-327960-1
#22-18	Red	MS 17143	16	--	--	AA-885-1	--	RA 485	327962
#16-14	Blue	MS 17143	17	--	--	BB-885-2	--	RB 485	2-327964-4
#12-10	Yellow	MS 17143	18	--	--	-	--	RC 485	327966
#22-18	Red	MS 17143	19	--	--	AA-886-1	--	RA 486	2-327968-1
#16-14	Blue	MS 17143	20	--	--	BB-886-2	--	RB 486	2-327970-4
#12-10	Yellow	MS 17143	21	--	--	--	--	RC 486	327972

NOTE: Component manufactures' instructions shall take precedence over the information presented in these charts. Wire ranges are for reference only.

HX4 TOOL SERIES OPTIONS FOR Y-DIES

- HX4 Hand Tools, p. 90 & 91
- HXE4B Battery Tools, p. 92
- HX23 Pneumatic Tool, p. 94

HX3 TOOL SERIES OPTIONS FOR X-DIES

- HX3 Hand Tools, p. 90 & 91

DMC does NOT provide connectors, contacts, or wiring components. Parts are shown here for reference only. See disclaimer of liability on page 27.



Similar Terminal Shown

MS20659-101 TO -106, SIZES 22 TO 10

TYPE: Class 1 Uninsulated Terminals, Ring Tongue
INSULATION: None
TERMINAL BODY & SLEEVE: Copper, ASTM B-152
PLATING: Tin, ASTM B-545
MAX TEMP RATING: 175° C

Tool Selection Guide

TERMINAL SPECS					DMC TOOL/DIE OPTIONS				
AWG	WIRE SIZE (MM)	INSULATION DIAMETER IN. (MM)	SLEEVE COLOR	TERMINAL/SPLICE PART NUMBER	HX4 SERIES MULTI-CAVITY (1 INDENT)	HX4 SERIES MULTI-CAVITY (2 INDENT)	GMT SERIES TOOL MIL-APPROVED (1 INDENT)	GMT SERIES TOOL (2 INDENT)	
#22-18	0.26-0.96	N/A	N/A	MS20659-	101	Y554 Die	Y788 Die	GMT277	GMT1005
					102	Y554 Die	Y788 Die	GMT277	GMT1005
#16-14	1.04 - 2.62	N/A	N/A	MS20659-	103	Y554 Die	Y788 Die	GMT277	GMT1005
					104	Y554 Die	Y788 Die	GMT277	GMT1005
#12-10	2.62 - 6.64	N/A	N/A	MS20659-	105	Y554 Die	Y788 Die	GMT277	GMT1005
					106	Y554 Die	Y788 Die	GMT277	GMT1005

NOTE: Terminals with optional insulation support must use Y554 or GMT277. The Y788 and GMT1005 are not applicable for terminals with optional insulation support.

Terminal Manufacturers' Part Numbers

TERMINAL SPECS				TERMINAL MANUFACTURERS' TERMINAL #					
AWG	SLEEVE COLOR	TERMINAL/SPLICE PART NUMBER		BURNDY	HOLLINGSWORTH	MOLEX	PANDUIT	THOMAS&BETTS	TYCO ELEC
#22-18	N/A	MS20659-	101	--	--	--	--	A85G	--
			102	--	--	--	--	A87G	--
#16-14	N/A	MS20659-	103	--	--	--	--	B85G	--
			104	--	--	--	--	B87G	--
#12-10	N/A	MS20659-	105	YAV10	R3457B	C-328-10	P10-10R	C26	33457
			106	YAV10-T2	R3459B	C-330-56	P10-56R	C70	33459

NOTE: Component manufactures' and OEM instructions shall take precedence over the information presented in these charts. Wire ranges are for reference only.

GMT TOOL SERIES OPTIONS

PMTxxx Pneumatic Tool, p. 101
 GMTxxx Hand Tool, p. 98 & 99
 GMTExxxB Battery Tool, p. 100

HX4 TOOL SERIES OPTIONS FOR Y-DIES

HX4 Hand Tools, p. 90 & 91
 HXE4B Battery Tools, p. 92
 HX23 Pneumatic Tool, p. 94

DMC does NOT provide connectors, contacts, or wiring components. Parts are shown here for reference only. See disclaimer of liability on page 27.



Similar Terminal Shown

MS20659-107 TO -116, SIZES 8 TO 1

TYPE: Class 1 Uninsulated Terminals, Ring Tongue

INSULATION: None

TERMINAL BODY & SLEEVE: Copper, ASTM B-152

PLATING: Tin, ASTM B-545

MAX TEMP RATING: 175° C

Tool Selection Guide

TERMINAL SPECS					DMC TOOL/DIE OPTIONS						
AWG	WIRE SIZE (MM)	INSULATION DIAMETER IN. (MM)	SLEEVE COLOR	TERMINAL/SPLICE PART NUMBER	HD485 SERIES DIE MIL-APPROVED (HEX)	HD51 SERIES DIE (HEX)	HD51 SERIES DIE (INDENT)	HD51 SERIES DIE MIL-APPROVED (HEX)	HD51 SERIES DIE MIL-APPROVED (INDENT)	HD36 SERIES DIE (INDENT)	
#8	6.64 - 10.5	N/A	N/A	MS20659-	107	HD485-8	HD51-163P	HD51-114N	HD51-192*	HD51-199*	HD36-111N
					108	HD485-8	HD51-163P	HD51-114N	HD51-192*	HD51-199*	HD36-111N
#6	10.5 - 16.8	N/A	N/A	MS20659-	109	HD485-6	HD51-164P	HD51-115N	HD51-193*	HD51-200*	HD36-112N
					110	HD485-6	HD51-164P	HD51-115N	HD51-193*	HD51-200*	HD36-112N
#4	16.8 - 26.7	N/A	N/A	MS20659-	111	HD485-4	HD51-165P	HD51-116N	HD51-194*	HD51-201*	HD36-113N
					112	HD485-4	HD51-165P	HD51-116N	HD51-194*	HD51-201*	HD36-113N
#2	26.7 - 42.4	N/A	N/A	MS20659-	113	HD485-2	--	HD51-117N	HD51-195*	HD51-202*	HD36-114N
					114	HD485-2	--	HD51-117N	HD51-195*	HD51-202*	HD36-114N
#1	40.0-42.0	N/A	N/A	MS20659-	115	HD485-1	HD51-166P	--	HD51-196*	--	--
					116	HD485-1	HD51-166P	--	HD51-196*	--	--

*QPL Pending

Terminal Manufacturers' Part Numbers

TERMINAL SPECS			TERMINAL MANUFACTURERS' TERMINAL #						
AWG	SLEEVE COLOR	TERMINAL/SPLICE PART NUMBER	BURNDY	HOLLINGSWORTH	MOLEX	PANDUIT	THOMAS&BETTS	TYCO ELEC	
#8	N/A	MS20659-	107	YAV8C-L	--	--	--	D10361	--
			108	YAV8C-L2	--	--	--	D10721	--
#6	N/A	MS20659-	109	YAV6C-L	--	--	--	E10711	--
			110	YAV6C-L2	--	--	--	E10731	--
#4	N/A	MS20659-	111	YAV4C-L	--	--	--	F10711	--
			112	YAV4C-L2	--	--	--	F10731	--
#2	N/A	MS20659-	113	YAV2C-L1	--	--	--	G971	--
			114	YAV2C-L	--	--	--	G973	--
#1	N/A	MS20659-	115	YAV1C-L1	--	--	--	H971	--
			116	YAV1C-L	--	--	--	H973	--

NOTE: Component manufactures' and OEM instructions shall take precedence over the information presented in these charts. Wire ranges are for reference only.

TBHD1M, HD120, HDE120B DIE/TOOL OPTIONS

HD120, HDE120B,
Hand Tool, p. 112-113
TBHD1M Hydraulic Tool, p. 112-113

HD36 TOOL SERIES OPTIONS

HD36 Hand Tool, p. 102
HDE36B Battery Tool, p. 103

HD51 TOOL SERIES OPTIONS

HD51 Hand Tool, p. 110-111
XHD51 Hydraulic Tool, p. 110-111
HDE51B Battery Tool - p. 110-111

DMC does not provide connectors, contacts or wiring components. Parts shown here are for reference only. See disclaimer of liability on page 27.



Similar Terminal Shown

MS20659-117 TO -124, SIZES 1/0 TO 4/0

TYPE: Class 1 Uninsulated Terminals, Ring Tongue
INSULATION: None
TERMINAL BODY & SLEEVE: Copper, ASTM B-152
PLATING: Tin, ASTM B-545
MAX TEMP RATING: 175° C

Tool Selection Guide

TERMINAL SPECS					DMC TOOL/DIE OPTIONS					
AWG	WIRE SIZE (MM)	INSULATION DIAMETER IN. (MM)	SLEEVE COLOR	TERMINAL/SPICE PART NUMBER	HD485 SERIES DIE MIL-APPROVED	HD51 SERIES DIE (HEX)	HD51 SERIES DIE (INDENT)	HD51 SERIES DIE MIL-APPROVED (HEX)	HD51 SERIES DIE MIL-APPROVED (INDENT)	
#1/0	42.4-60.6	N/A	N/A	MS20659-	117	HD485-01	HD51-167P	HD51-122N	HD51-197*	HD51-203
					118	HD485-01	HD51-167P	HD51-122N	HD51-197*	HD51-203
#2/0	60.6-76.3	N/A	N/A	MS20659-	119	HD485-02	HD51-168P	HD51-125N	HD51-198*	HD51-204
					120	HD485-02	HD51-168P	HD51-125N	HD51-198*	HD51-204
#3/0	76.3-96.3	N/A	N/A	MS20659-	121	HD485-03	--	--	--	--
					122	HD485-03	--	--	--	--
#4/0	96.3-117	N/A	N/A	MS20659-	123	HD485-04	--	--	--	--
					124	HD485-04	--	--	--	--

*QPL in Progress

Terminal Manufacturers' Part Numbers

TERMINAL SPECS			TERMINAL MANUFACTURERS' TERMINAL #						
AWG	SLEEVE COLOR	TERMINAL/SPICE PART NUMBER	BURNDY	HOLLINGSWORTH	MOLEX	PANDUIT	THOMAS&BETTS	TYCO ELEC	
#1/0	N/A	MS20659-	117	YAV25-L1	--	--	--	J971	--
			118	YAV25-L	--	--	--	J973	--
#2/0	N/A	MS20659-	119	YAV26-L2	--	--	--	K972	--
			120	YAV26-L	--	--	--	K973	--
#3/0	N/A	MS20659-	121	YAV27-L	--	--	--	L973	--
			122	YAV27-L1	--	--	--	L975	--
#4/0	N/A	MS20659-	123	YAV28-L	--	--	--	M973	--
			124	YAV28-L12	--	--	--	M975	--

NOTE: Component manufactures' and OEM instructions shall take precedence over the information presented in these charts. Wire ranges are for reference only.

TBHD1M, HD120, HDE120B DIE/TOOL OPTIONS

HD120, HDE120B,
 Hand Tool, p. 112-113
 TBHD1M Hydraulic Tool, p. 112-113

HD51 TOOL SERIES OPTIONS

HD51 Hand Tool, p. 110-111
 XHD51 Hydraulic Tool, p. 110-111
 HDE51B Battery Tool - p. 110-111

DMC does not provide connectors, contacts or wiring components. Parts shown here are for reference only. See disclaimer of liability on page 27.



Similar Terminal Shown

MS20659-125 TO -128, SIZES 22 TO 10

TYPE: Class 1 Uninsulated Terminals, Ring Tongue

INSULATION: None

TERMINAL BODY & SLEEVE: Copper, ASTM B-152

PLATING: Tin, ASTM B-545

MAX TEMP RATING: 175° C

Tool Selection Guide

TERMINAL SPECS					DMC TOOL/DIE OPTIONS				
AWG	WIRE SIZE (MM)	INSULATION DIAMETER IN. (MM)	SLEEVE COLOR	TERMINAL/SPLICE PART NUMBER		HX4 SERIES DIE MULTI-CAVITY (1 INDENT)	HX4 SERIES DIE MULTI-CAVITY (2 INDENT)	GMT SERIES TOOL MIL-APPROVED (1 INDENT)	GMT SERIES TOOL (2 INDENT)
#22-18	0.26 - 0.96	N/A	N/A	MS20659-	125	Y554	Y788	GMT277	GMT1005
#16-14	1.04 - 2.62	N/A	N/A	MS20659-	126	Y554	Y788	GMT277	GMT1005
					127	Y554	Y788	GMT277	GMT1005
#12-10	2.62 - 6.64	N/A	N/A	MS20659-	128	Y554	Y788	GMT277	GMT1005

NOTE: Terminals with optional insulation support must use Y554 or GMT277. The Y788 and GMT1005 are not applicable for terminals with optional insulation support.

Terminal Manufacturers' Part Numbers

TERMINAL SPECS				TERMINAL MANUFACTURERS' TERMINAL #					
AWG	SLEEVE COLOR	TERMINAL/SPLICE PART NUMBER		BURNDY	HOLLINGSWORTH	MOLEX	PANDUIT	THOMAS&BETTS	TYCO ELEC
#22-18	N/A	MS20659-	125	--	--	--	--	--	--
#16-14	N/A	MS20659-	126	--	--	--	--	--	--
		MS20659-	127	--	--	--	--	--	--
#12-10	N/A	MS20659-	128	YAV10-T4	R3220B	C-340-38	P10-38R	C73	33220

NOTE: Component manufactures' and OEM instructions shall take precedence over the information presented in these charts. Wire ranges are for reference only.

GMT TOOL SERIES OPTIONS

PMTxxx Pneumatic Tool, p. 101
 GMTxxx Hand Tool, p. 98 & 99
 GMTExxx Battery Tool, p. 100

HX4 TOOL SERIES OPTIONS FOR Y-DIES

HX4 Hand Tools, p. 90 & 91
 HXE4B Battery Tools, p. 92
 HX23 Pneumatic Tool, p. 94

DMC does NOT provide connectors, contacts, or wiring components. Parts are shown here for reference only. See disclaimer of liability on page 27.



Similar Terminal Shown

MS20659-129 TO -134, SIZES 6 TO 1

TYPE: Class 1 Uninsulated Terminals, Ring Tongue
INSULATION: None
TERMINAL BODY & SLEEVE: Copper, ASTM B-152
PLATING: Tin, ASTM B-545
MAX TEMP RATING: 175° C

Tool Selection Guide

TERMINAL SPECS					DMC TOOL/DIE OPTIONS					
AWG	WIRE SIZE (MM)	INSULATION DIAMETER IN. (MM)	SLEEVE COLOR	TERMINAL/ SPLICE PART NUMBER	HD485 SEIRES DIE MIL-APPROVED (HEX)	HD51 SERIES DIE (HEX)	HD51 SERIES DIE (INDENT)	HD51 SERIES DIE MIL-APPROVED (HEX)	HD51 SERIES DIE MIL-APPROVED (INDENT)	HD36 SERIES DIE (INDENT)
#8	6.64 - 10.5	N/A	N/A	MS20659-129	HD485-8	HD51-163P	HD51-114N	HD51-192*	HD51-199*	HD36-111N
#6	10.5 - 16.8	N/A	N/A	MS20659-130	HD485-6	HD51-164P	HD51-115N	HD51-193*	HD51-199*	HD36-112N
					HD485-6	HD51-164P	HD51-115N	HD51-193*	HD51-200*	HD36-112N
#4	16.8 - 26.7	N/A	N/A	MS20659-132	HD485-4	HD51-165P	HD51-116N	HD51-194*	HD51-200*	HD36-113N
#2	26.7 - 42.4	N/A	N/A	MS20659-133	HD485-2	--	HD51-117N	HD51-195*	HD51-201*	HD36-113N
#1	40.0-42.0	N/A	N/A	MS20659-134	HD485-1	HD51-166P	--	HD51-196*	HD51-201*	--

*QPL in Progress

NOTE: Terminals with optional insulation support must use Y554 or GMT277. The Y788 and GMT1005 are not applicable for terminals with optional insulation support.

Terminal Manufacturers' Part Numbers

TERMINAL SPECS				TERMINAL MANUFACTURERS' TERMINAL #					
AWG	SLEEVE COLOR	TERMINAL/SPLICE PART NUMBER		BURNDY	HOLLINGSWORTH	MOLEX	PANDUIT	THOMAS&BETTS	TYCO ELEC
#8	N/A	MS20659-	129	YAV8C-L3	--	--	--	D10731	--
#6	N/A	MS20659-	130	YAV6C-L1	--	--	--	E10261	--
#6	N/A	MS20659-	131	YAV6C-L4	--	--	--	E10721	--
#4	N/A	MS20659-	132	YAV4C-L4	--	--	--	F10721	--
#2	N/A	MS20659-	133	YAV2C-L4	--	--	--	G975	--
#1	N/A	MS20659-	134	YAV1C-L3	--	--	--	H975	--

NOTE: Component manufactures' and OEM instructions shall take precedence over the information presented in these charts. Wire ranges are for reference only.

TBHD1M, HD120, HDE120B DIE/TOOL OPTIONS

HD120, HDE120B,
Hand Tool, p. 112-113
TBHD1M Hydraulic Tool, p. 112-113

HD36 TOOL SERIES OPTIONS

HD36 Hand Tool, p. 102
HDE36B Battery Tool, p. 103

HD51 TOOL SERIES OPTIONS

HD51 Hand Tool, p. 110-111
XHD51 Hydraulic Tool, p. 110-111
HDE51B Battery Tool - p. 110-111

DMC does not provide connectors, contacts or wiring components. Parts shown here are for reference only. See disclaimer of liability on page 27.



Similar Terminal Shown

MS20659-135 TO -137, SIZES 1/0 TO 4/0

TYPE: Class 1 Uninsulated Terminals, Ring Tongue

INSULATION: None

TERMINAL BODY & SLEEVE: Copper, ASTM B-152

PLATING: Tin, ASTM B-545

MAX TEMP RATING: 175° C

Tool Selection Guide

TERMINAL SPECS					DMC TOOL/DIE OPTIONS					
AWG	WIRE SIZE (MM)	INSULATION DIAMETER IN. (MM)	SLEEVE COLOR	TERMINAL/SPLICE PART NUMBER	HD485 SERIES DIE MIL-APPROVED* (HEX)	HD51 SERIES DIE (HEX)	HD51 SERIES DIE (INDENT)	HD51 SERIES DIE MIL-APPROVED (HEX)	HD51 SERIES DIE MIL-APPROVED (INDENT)	
#1/0	42.4-60.6	N/A	N/A	MS20659- 135	HD485-01	HD51-167P	HD51-122N	HD51-197*	HD51-203*	
#2/0	60.6-76.3	N/A	N/A	MS20659- 136	HD485-02	HD51-168P	HD51-125N	HD51-198*	HD51-204*	
#4/0	96.3-117	N/A	N/A	MS20659- 137	HD485-04	--	--	--	--	

*QPL in Progress

Terminal Manufacturers' Part Numbers

TERMINAL SPECS				TERMINAL MANUFACTURERS' TERMINAL #					
AWG	SLEEVE COLOR	TERMINAL/SPLICE PART NUMBER		BURNDY	HOLLINGSWORTH	MOLEX	PANDUIT	THOMAS&BETTS	TYCO ELEC
#1/0	N/A	MS20659-	135	YAV25-L3	--	--	--	J975	--
#2/0	N/A	MS20659-	136	YAV26-L3	--	--	--	K975	--
#4/0	N/A	MS20659-	137	YAV28-L54	--	--	--	--	--

NOTE: Component manufactures' and OEM instructions shall take precedence over the information presented in these charts. Wire ranges are for reference only.

TBHD1M, HD120, HDE120B DIE/TOOL OPTIONS

HD120, HDE120B,
Hand Tool, p. 112-113
TBHD1M Hydraulic Tool, p. 112-113

HD51 TOOL SERIES OPTIONS

HD51 Hand Tool, p. 110-111
XHD51 Hydraulic Tool, p. 110-111
HDE51B Battery Tool - p. 110-111

DMC does not provide connectors, contacts or wiring components. Parts shown here are for reference only. See disclaimer of liability on page 27.



Similar Terminal Shown

MS20659-140 TO -150, SIZES 8 TO 1

TYPE: Class 1 Uninsulated Terminals, Ring Tongue

INSULATION: None

TERMINAL BODY & SLEEVE: Copper, ASTM B-152

PLATING: Tin, ASTM B-545

MAX TEMP RATING: 175° C

Tool Selection Guide

TERMINAL SPECS					DMC TOOL/DIE OPTIONS						
AWG	WIRE SIZE MM	INSULATION DIAMETER IN. (MM)	SLEEVE COLOR	TERMINAL/ SPLICE PART NUMBER	HD485 SERIES DIE MIL-APPROVED (HEX)	HD51 SERIES DIE (HEX)	HD51 SERIES DIE (INDENT)	HD51 SERIES DIE MIL-APPROVED (HEX)	HD51 SERIES DIE MIL-APPROVED (INDENT)	HD36 SERIES DIE (INDENT)	
#8	6.64 - 10.5	N/A	N/A	MS20659-	140	HD485-8	HD51-163P	HD51-114N	HD51-192*	HD51-199*	HD36-111N
					141	HD485-8	HD51-163P	HD51-114N	HD51-192*	HD51-199*	HD36-111N
					142	HD485-8	HD51-163P	HD51-114N	HD51-192*	HD51-200*	HD36-111N
#6	10.5 - 16.8	N/A	N/A	MS20659-	143	HD485-6	HD51-164P	HD51-115N	HD51-193*	HD51-200*	HD36-112N
#4	16.8 - 26.7	N/A	N/A	MS20659-	144	HD485-4	HD51-165P	HD51-116N	HD51-194*	HD51-201*	HD36-113N
					145	HD485-4	HD51-165P	HD51-116N	HD51-194*	HD51-201*	HD36-113N
#2	26.7 - 42.4	N/A	N/A	MS20659-	146	HD485-2	--	HD51-117N	HD51-195*	HD51-202*	HD36-114N
					147	HD485-2	--	HD51-117N	HD51-195*	HD51-202*	HD36-114N
					148	HD485-2	--	HD51-117N	HD51-195*	HD51-202*	HD36-114N
#1	40.0-42.0	N/A	N/A	MS20659-	149	HD485-1	HD51-166P	--	HD51-196*	--	--
					150	HD485-1	HD51-166P	--	HD51-196*	--	--

*QPL in Progress

Terminal Manufacturers' Part Numbers

TERMINAL SPECS			TERMINAL MANUFACTURERS' TERMINAL #						
AWG	SLEEVE COLOR	TERMINAL/SPLICE PART NUMBER	BURNDY	HOLLINGSWORTH	MOLEX	PANDUIT	THOMAS&BETTS	TYCO ELEC	
#8	N/A	MS20659-	140	YAV8C-L14	--	--	--	D10161	--
			141	YAV8C-L1	--	--	--	D10711	--
			142	YAV8C-L4	--	--	--	--	--
#6	N/A	MS20659-	143	YAV6C-L10	--	--	--	--	
#4	N/A	MS20659-	144	YAV4C-L3	--	--	--	F10261	--
			145	YAV4C-L5	--	--	--	--	--
#2	N/A	MS20659-	146	YAV2C-L3	--	--	--	G926	--
			147	YAV2C-L2	--	--	--	G972	--
			148	YAV2C-L11	--	--	--	G974	--
#1	N/A	MS20659-	149	YAV1C-L2	--	--	--	H972	--
			150	YAV1C-L4	--	--	--	H974	--

NOTE: Component manufactures' and OEM instructions shall take precedence over the information presented in these charts. Wire ranges are for reference only.

TBHD1M, HD120, HDE120B DIE/TOOL OPTIONS

HD120, HDE120B,
Hand Tool, p. 112-113
TBHD1M Hydraulic Tool, p. 112-113

HD36 TOOL SERIES OPTIONS

HD36 Hand Tool, p. 102
HDE36B Battery Tool, p. 103

HD51 TOOL SERIES OPTIONS

HD51 Hand Tool, p. 110-111
XHD51 Hydraulic Tool, p. 110-111
HDE51B Battery Tool - p. 110-111

DMC does not provide connectors, contacts or wiring components. Parts shown here are for reference only. See disclaimer of liability on page 27.



Similar Terminal Shown

MS20659-151 TO -160, SIZES 1/0 TO 4/0

TYPE: Class 1 Uninsulated Terminals, Ring Tongue

INSULATION: None

TERMINAL BODY & SLEEVE: Copper, ASTM B-152

PLATING: Tin, ASTM B-545

MAX TEMP RATING: 175° C

Tool Selection Guide

TERMINAL SPECS					DMC TOOL/DIE OPTIONS					
AWG	WIRE SIZE MM	INSULATION DIAMETER IN. (MM)	SLEEVE COLOR	TERMINAL/SPLICE PART NUMBER	HD485 SERIES DIE MIL-APPROVED (HEX)	HD51 SERIES DIE (HEX)	HD51 SERIES DIE (INDENT)	HD51 SERIES DIE MIL-APPROVED (HEX)	HD51 SERIES DIE MIL-APPROVED (INDENT)	
1/0	42.4-60.6	N/A	N/A	MS20659-	151	HD485-01	HD51-167P	HD51-122N	HD51-197*	HD51-203*
					152	HD485-01	HD51-167P	HD51-122N	HD51-197*	HD51-203*
2/0	60.6-76.3	N/A	N/A	MS20659-	153	HD485-02	HD51-168P	HD51-125N	HD51-198*	HD51-204*
					154	HD485-02	HD51-168P	HD51-125N	HD51-198*	HD51-204*
3/0	76.3-96.3	N/A	N/A	MS20659-	155	HD485-03	--	--	--	--
					156	HD485-03	--	--	--	--
4/0	96.3-117	N/A	N/A	MS20659-	157	HD485-04	--	--	--	--
					158	HD485-04	--	--	--	--
					159	HD485-04	--	--	--	--
					160	HD485-04	--	--	--	--

*QPL in Progress

Terminal Manufacturers' Part Numbers

TERMINAL SPECS			TERMINAL MANUFACTURERS' TERMINAL #						
AWG	SLEEVE COLOR	TERMINAL/SPLICE PART NUMBER	BURNDY	HOLLINGSWORTH	MOLEX	PANDUIT	THOMAS&BETTS	TYCO ELEC	
1/0	N/A	MS20659-	151	YAV25-L2	--	--	J972	--	
			152	YAV25-L16	--	--	J974	--	
2/0	N/A	MS20659-	153	YAV26-L1	--	--	K971	--	
			154	YAV26-L16	--	--	K974	--	
3/0	N/A	MS20659-	155	YAV27-L20	--	--	L972	--	
			156	YAV27-L18	--	--	L974	--	
4/0	N/A	MS20659-	157	YAV28-L56	--	--	M972	--	
			158	YAV28-L60	--	--	M974	--	
			159	YAV28-L13	--	--	--	--	
			160	YAV28-L14	--	--	--	--	

NOTE: Component manufactures' and OEM instructions shall take precedence over the information presented in these charts. Wire ranges are for reference only.

TBHD1M, HD120, HDE120B DIE/TOOL OPTIONS

HD120, HDE120B,
Hand Tool, p. 112-113
TBHD1M Hydraulic Tool, p. 112-113

HD51 TOOL SERIES OPTIONS

HD51 Hand Tool, p. 110-111
XHD51 Hydraulic Tool, p. 110-111
HDE51B Battery Tool - p. 110-111

DMC does not provide connectors, contacts or wiring components. Parts shown here are for reference only. See disclaimer of liability on page 27.



Similar Terminal Shown

MS20659-161 TO -166, SIZES 22 TO 10

TYPE: Class 1 Uninsulated Terminals, Ring Tongue
INSULATION: None
TERMINAL BODY & SLEEVE: Copper, ASTM B-152
PLATING: Tin, ASTM B-545
MAX TEMP RATING: 175° C

Tool Selection Guide

TERMINAL SPECS					DMC TOOL/DIE OPTIONS					
AWG	WIRE SIZE (MM)	INSULATION DIAMETER IN. (MM)	SLEEVE COLOR	TERMINAL/ SPLICE PART NUMBER	HX4 DIE SERIES MULTI-CAVITY (1 INDENT)	HX4 SERIES MULTI-CAVITY (2 INDENT)	GMT SERIES TOOL (1 INDENT)	GMT SERIES TOOL MIL-APPROVED (2 INDENT)	DCT4 SERIES TOOL	
#22-18	0.26 - 0.96	N/A	N/A	MS20659-	161	Y554	Y788	GMT277	GMT1005	DCT4-105D
					162	Y554	Y788	GMT277	GMT1005	DCT4-105D
#16-14	1.04 - 2.62	N/A	N/A	MS20659-	163	Y554	Y788	GMT277	GMT1005	DCT4-105D
					164	Y554	Y788	GMT277	GMT1005	DCT4-105D
#12-10	2.62 - 6.64	N/A	N/A	MS20659-	165	Y554	Y788	GMT277	GMT1005	DCT4-105D
					166	Y554	Y788	GMT277	GMT1005	DCT4-105D

NOTE: Terminals with optional insulation support must use Y554 or GMT277. The Y788 and GMT1005 are not applicable for terminals with optional insulation support.

Terminal Manufacturers' Part Numbers

TERMINAL SPECS			TERMINAL MANUFACTURERS' TERMINAL #						
AWG	SLEEVE COLOR	TERMINAL/SPLICE PART NUMBER	BURNDY	HOLLINGSWORTH	MOLEX	PANDUIT	THOMAS&BETTS	TYCO ELEC	
#22-18	N/A	MS20659-	161	--	--	--	--	--	
			162	--	--	--	--	--	
#16-14	N/A	MS20659-	163	--	--	--	--	--	
			164	--	--	--	--	--	
#12-10	N/A	MS20659-	165	YAV10-T7	R3453B	--	P10-6R	C33	
			166	--	R3223B	--	--	C75	

NOTE: Component manufactures' and OEM instructions shall take precedence over the information presented in these charts. Wire ranges are for reference only.

GMT TOOL SERIES OPTIONS

PMTxxx Pneumatic Tool, p. 101
 GMTxxx Hand Tool, p. 98 & 99
 GMTExxxB Battery Tool, p. 100

HX4 TOOL SERIES OPTIONS FOR Y-DIES

HX4 Hand Tools, p. 90 & 91
 HXE4B Battery Tools, p. 92
 HX23 Pneumatic Tool, p. 94

DMC does NOT provide connectors, contacts, or wiring components. Parts are shown here for reference only. See disclaimer of liability on page 27.

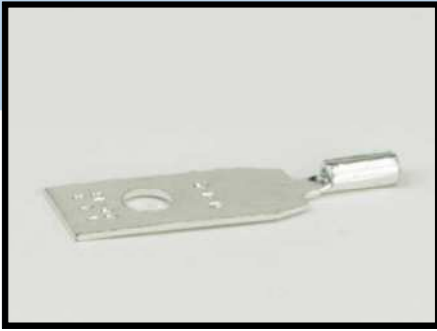

Similar Terminal Shown

MS21004-1 TO -7, SIZES 22 TO 18

TYPE: Class 1 Uninsulated Terminals, Rectangular Tongue

INSULATION: None

TERMINAL BODY & SLEEVE: Copper, ASTM B-152

PLATING: Tin, ASTM B-545

MAX TEMP RATING: 175° C

Tool Selection Guide

TERMINAL SPECS				DMC TOOL/DIE OPTIONS					
AWG	WIRE SIZE MM	INSULATION DIAMETER IN. (MM)	SLEEVE COLOR	TERMINAL/SPLICE PART NUMBER	HX4 SERIES DIE MULTI-CAVITY (1 INDENT)	HX4 SERIES DIE MULTI-CAVITY (2 INDENT)	GMT SERIES TOOL MIL-APPROVED (1 INDENT)	GMT SERIES TOOL (2 INDENT)	
#22-18	0.26-0.96	N/A	N/A	MS21004-	1	Y554	Y788	GMT277	GMT1005
					2	Y554	Y788	GMT277	GMT1005
					3	Y554	Y788	GMT277	GMT1005
					4	Y554	Y788	GMT277	GMT1005
					5	Y554	Y788	GMT277	GMT1005
					6	Y554	Y788	GMT277	GMT1005
					7	Y554	Y788	GMT277	GMT1005

Terminal Manufacturers' Part Numbers

TERMINAL SPECS			TERMINAL MANUFACTURERS' TERMINAL #						
AWG	SLEEVE COLOR	TERMINAL/SPLICE PART NUMBER	BURNDY	HOLLINGSWORTH	MOLEX	PANDUIT	THOMAS&BETTS	TYCO ELEC	
#22-18	N/A	MS21004-	1	--	--	--	--	A486	--
			2	--	--	--	--	A483	--
			3	--	--	--	--	A482	--
			4	--	--	--	--	A481	--
			5	--	--	--	--	A485	--
			6	--	--	--	--	A484	--
			7	--	--	--	--	A480	--

NOTE: Component manufactures' and OEM instructions shall take precedence over the information presented in these charts. Wire ranges are for reference only.

GMT TOOL SERIES OPTIONS

- PMTxxx Pneumatic Tool, p. 101
- GMTxxx Hand Tool, p. 98 & 99
- GMTExxx Battery Tool, p. 100

HX4 TOOL SERIES OPTIONS FOR Y-DIES

- HX4 Hand Tools, p. 90 & 91
- HXE4B Battery Tools, p. 92
- HX23 Pneumatic Tool, p. 94

DMC does NOT provide connectors, contacts, or wiring components. Parts are shown here for reference only. See disclaimer of liability on page 27.



Similar Terminal Shown

MS21004-8 TO -14, SIZES 16 TO 14

TYPE: Class 1 Uninsulated Terminals, Rectangular Tongue

INSULATION: None

TERMINAL BODY & SLEEVE: Copper, ASTM B-152

PLATING: Tin, ASTM B-545

MAX TEMP RATING: 175° C

Tool Selection Guide

TERMINAL SPECS				DMC TOOL/DIE OPTIONS					
AWG	WIRE SIZE MM	INSULATION DIAMETER IN. (MM)	SLEEVE COLOR	TERMINAL/SPLICE PART NUMBER	HX4 SERIES DIE MULTI-CAVITY (1 INDENT)	HX4 SERIES DIE MULTI-CAVITY (2 INDENT)	GMT SERIES TOOL MIL-APPROVED (1 INDENT)	GMT SERIES TOOL (2 INDENT)	
#16-14	1.04 - 2.62	N/A	N/A	MS21004-	8	Y554	Y788	GMT277	GMT1005
					9	Y554	Y788	GMT277	GMT1005
					10	Y554	Y788	GMT277	GMT1005
					11	Y554	Y788	GMT277	GMT1005
					12	Y554	Y788	GMT277	GMT1005
					13	Y554	Y788	GMT277	GMT1005
					14	Y554	Y788	GMT277	GMT1005

Terminal Manufacturers' Part Numbers

TERMINAL SPECS			TERMINAL MANUFACTURERS' TERMINAL #						
AWG	SLEEVE COLOR	TERMINAL/SPLICE PART NUMBER	BURNDY	HOLLINGSWORTH	MOLEX	PANDUIT	THOMAS&BETTS	TYCO ELEC	
#16-14	N/A	MS21004-	8	--	--	--	--	B486	--
			9	--	--	--	--	B483	--
			10	--	--	--	--	B482	--
			11	--	--	--	--	B481	--
			12	--	--	--	--	B485	--
			13	--	--	--	--	B484	--
			14	--	--	--	--	B480	--

NOTE: Component manufactures' and OEM instructions shall take precedence over the information presented in these charts. Wire ranges are for reference only.

GMT TOOL SERIES OPTIONS

- PMTxxx Pneumatic Tool, p. 101
- GMTxxx Hand Tool, p. 98 & 99
- GMTExxx Battery Tool, p. 100

HX4 TOOL SERIES OPTIONS FOR Y-DIES

- HX4 Hand Tools, p. 90 & 91
- HXE4B Battery Tools, p. 92
- HX23 Pneumatic Tool, p. 94

DMC does NOT provide connectors, contacts, or wiring components. Parts are shown here for reference only. See disclaimer of liability on page 27.



Similar Terminal Shown

MS21004-15 TO -21, SIZES 12 TO 10

TYPE: Class 1 Uninsulated Terminals, Rectangular Tongue

INSULATION: None

TERMINAL BODY & SLEEVE: Copper, ASTM B-152

PLATING: Tin, ASTM B-545

MAX TEMP RATING: 175° C

Tool Selection Guide

TERMINAL SPECS					DMC TOOL/DIE OPTIONS				
AWG	WIRE SIZE MM	INSULATION DIAMETER IN. (MM)	SLEEVE COLOR	TERMINAL/SPLICE PART NUMBER	HX4 SERIES DIE MULTI-CAVITY (1 INDENT)	HX4 SERIES DIE MULTI-CAVITY (2 INDENT)	GMT SERIES TOOL MIL-APPROVED (1 INDENT)	GMT SERIES TOOL (2 INDENT)	
#12-10	2.62 - 6.64	N/A	N/A	MS21004-	15	Y554	Y788	GMT277	GMT1005
					16	Y554	Y788	GMT277	GMT1005
					17	Y554	Y788	GMT277	GMT1005
					18	Y554	Y788	GMT277	GMT1005
					19	Y554	Y788	GMT277	GMT1005
					20	Y554	Y788	GMT277	GMT1005
					21	Y554	Y788	GMT277	GMT1005

Terminal Manufacturers' Part Numbers

TERMINAL SPECS			TERMINAL MANUFACTURERS' TERMINAL #						
AWG	SLEEVE COLOR	TERMINAL/SPLICE PART NUMBER	BURNDY	HOLLINGSWORTH	MOLEX	PANDUIT	THOMAS&BETTS	TYCO ELEC	
#12-10	N/A	MS21004-	15	--	--	--	--	C486	--
			16	--	--	--	--	C483	--
			17	--	--	--	--	C482	--
			18	--	--	--	--	C481	--
			19	--	--	--	--	C485	--
			20	--	--	--	--	C484	--
			21	--	--	--	--	C480	--

NOTE: Component manufactures' and OEM instructions shall take precedence over the information presented in these charts. Wire ranges are for reference only.

GMT TOOL SERIES OPTIONS

PMTxxx Pneumatic Tool, p. 101
 GMTxxx Hand Tool, p. 98 & 99
 GMTExxx Battery Tool, p. 100

HX4 TOOL SERIES OPTIONS FOR Y-DIES

HX4 Hand Tools, p. 90 & 91
 HXE4B Battery Tools, p. 92
 HX23 Pneumatic Tool, p. 94

DMC does NOT provide connectors, contacts, or wiring components. Parts are shown here for reference only. See disclaimer of liability on page 27.



Similar Terminal Shown

MS25036-101 TO -110, SIZES 22 TO 14

TYPE: Class 1 Insulated Terminals

INSULATION: Nylon, UL 94V-2

TERMINAL BODY & SLEEVE: Copper, ASTM B-152

PLATING: Tin, ASTM B-545

MAX TEMP RATING: 105° C

Tool Selection Guide

TERMINAL SPECS					DMC TOOL/DIE OPTIONS					
AWG	WIRE SIZE MM	INSULATION DIAMETER IN. (MM)	SLEEVE COLOR	TERMINAL/SPLICE PART NUMBER	HX3 SERIES DIE MIL-APPROVED	HX4 SERIES DIE MIL-APPROVED (MULTI-CAVITY)	HX4 SERIES DIE MIL-APPROVED (SINGLE CAVITY)	HX4 SERIES DIE (SINGLE CAVITY)	M22520/40-01 TOOL MIL-APPROVED	
#22-18	0.26-0.96	.140 (3.56)	Red	MS25036-	101	X511	Y501	Y1115*	Y672	AMT4001
					102	X511	Y501	Y1115*	Y672	AMT4001
					103	X511	Y501	Y1115*	Y672	AMT4001
					104	X511	Y501	Y1115*	Y672	AMT4001
					105	X511	Y501	Y1115*	Y672	AMT4001
#16-14	1.04 - 2.62	.170 (4.32)	Blue	MS25036-	106	X511	Y501	Y1116*	Y671	AMT4001
					107	X511	Y501	Y1116*	Y671	AMT4001
					108	X511	Y501	Y1116*	Y671	AMT4001
					109	X511	Y501	Y1116*	Y671	AMT4001
					110	X511	Y501	Y1116*	Y671	AMT4001

*QPL in progress, die set includes insulation adjustment feature.

Terminal Manufacturers' Part Numbers

TERMINAL SPECS			TERMINAL MANUFACTURERS' TERMINAL #							
AWG	SLEEVE COLOR	TERMINAL/SPLICE PART NUMBER	BURNDY	HOLLINGSWORTH	MOLEX	PANDUIT	THOMAS&BETTS	TYCO ELEC		
#22-18	Red	MS25036-	101	YAES18-N1	XR1881 SN	AA-820-06	PN18-6RN	RA333	36150	36149
			102	YAES18-N2	XR1885 SN	AA-832-06	PN18-6R	RA853	51863	--
			103	YAES18-N3	XR1891 SN	AA-821-10	PN18-10R	RA873	36154	36153
			104	YAES18-N4	XR1895 SN	AA-822-56	PN18-56R	RA723	31895	320572
			105	YAES18-N5	XR1896 SN	AA-826-38	PN18-38R	RA733	31897	320573
#16-14	Blue	MS25036-	106	YAES14-N6	XR2442 SN	BB-823-06	PN14-6RN	RB1333	320561	--
			107	YAES14-N7	XR1901 SN	BB-837-06	PN14-6R	RB853	51864	--
			108	YAES14-N8	XR1903 SN	BB-837-10	PN14-10R	RB873	51864-2	--
			109	YAES14-N9	XR1907 SN	BB-825-56	PN14-56R	RB723	320575	--
			110	YAES14-N10	XR1908 SN	BB-818-38	PN14-38R	RB733	320564	--

NOTE: Component manufactures' and OEM instructions shall take precedence over the information presented in these charts. Wire ranges are for reference only.

HX4 TOOL SERIES OPTIONS FOR Y-DIES

HX4 Hand Tools, p. 90 & 91
 HXE4B Battery Tools, p. 92
 HX23 Pneumatic Tool, p. 94

HX3 TOOL SERIES OPTIONS FOR X-DIES

HX3 Hand Tools, p. 90 & 91

DMC does NOT provide connectors, contacts, or wiring components. Parts are shown here for reference only. See disclaimer of liability on page 27.



Similar Terminal Shown

MS25036-111 TO -114, SIZES 12 TO 10

TYPE: Class 1 Insulated Terminals

INSULATION: Nylon, UL 94V-2

TERMINAL BODY & SLEEVE: Copper, ASTM B-152

PLATING: Tin, ASTM B-545

MAX TEMP RATING: 105° C

Tool Selection Guide

TERMINAL SPECS					DMC TOOL/DIE OPTIONS				
AWG	WIRE SIZE MM	INSULATION DIAMETER IN. (MM)	SLEEVE COLOR	TERMINAL/SPLICE PART NUMBER	HX3 SERIES DIE MIL-APPROVED	HX4 SERIES DIE MIL-APPROVED (MULTI-CAVITY)	HX4 SERIES DIE (SINGLE CAVITY)	HX4 SERIES DIE (SINGLE CAVITY)	
#12-10	2.62 - 6.64	.230 (5.84)	Yellow	MS25036-	111	X515	Y501	Y1117*	Y670
					112	X515	Y501	Y1117*	Y670
					113	X515	Y501	Y1117*	Y670
					114	X515	Y501	Y1117*	Y670

*QPL in progress, die set includes insulation adjustment feature

Terminal Manufacturers' Part Numbers

TERMINAL SPECS			TERMINAL MANUFACTURERS' TERMINAL #							
AWG	SLEEVE COLOR	TERMINAL/SPLICE PART NUMBER	BURNDY	HOLLINGSWORTH	MOLEX	PANDUIT	THOMAS&BETTS	TYCO ELEC		
#12-10	Yellow	MS25036-	111	YAES10-N11	XR5107 N	C-828-06	PN10-6R	RC333	320567	35107
			112	YAES10-N12	XR5109 N	C-828-10	PN10-10R	RC363	36161	35109
			113	YAES10-N13	XR5111 N	C-830-56	PN10-56R	RC703	320576	35111
			114	YAES10-N14	XR5112 N	C-840-38	PN10-38R	RC733	320577	35112

NOTE: Component manufactures' and OEM instructions shall take precedence over the information presented in these charts. Wire ranges are for reference only.

HX4 TOOL SERIES OPTIONS FOR Y-DIES

HX4 Hand Tools, p. 90 & 91
 HXE4B Battery Tools, p. 92
 HX23 Pneumatic Tool, p. 94

HX3 TOOL SERIES OPTIONS FOR X-DIES

HX3 Hand Tools, p. 90 & 91

DMC does NOT provide connectors, contacts, or wiring components. Parts are shown here for reference only. See disclaimer of liability on page 27.



Similar Terminal Shown

MS25036-115 TO -122, SIZES 8 TO 6

TYPE: Class 1 Insulated Terminals

INSULATION: Nylon, UL 94V-2

TERMINAL BODY & SLEEVE: Copper, ASTM B-152

PLATING: Tin, ASTM B-545

MAX TEMP RATING: 105° C

Tool Selection Guide*

TERMINAL SPECS					DMC TOOL/DIE OPTIONS				
AWG	WIRE SIZE (MM)	INSULATION DIAMETER IN. (MM)	SLEEVE COLOR	TERMINAL/SPLICE PART NUMBER	HD002 SERIES DIE MIL-APPROVED (HEX)	HD51 SERIES DIE (HEX)	HD36 SERIES DIE (INDENT)		
#8	6.64 - 10.5	.290 (7.55)	Red	MS25036-	115	HD002-8	HD51-105	HD36-139	
					116	HD002-8	HD51-105	HD36-139	
					117	HD002-8	HD51-105	HD36-139	
					118	HD002-8	HD51-105	HD36-139	
#6	10.5 - 16.8	.370 (9.55)	Blue	MS25036-	119	HD002-6	HD51-106	HD36-136	
					120	HD002-6	HD51-106	HD36-136	
					121	HD002-6	HD51-106	HD36-136	
					122	HD002-6	HD51-106	HD36-136	

*QPL in Progress

Terminal Manufacturers' Part Numbers

TERMINAL SPECS			TERMINAL MANUFACTURERS' TERMINAL #						
AWG	SLEEVE COLOR	TERMINAL/SPLICE PART NUMBER	BURNDY	HOLLINGSWORTH	MOLEX	PANDUIT	THOMAS&BETTS	TYCO ELEC	
#8	Red	MS25036-	115	YAEV8C-L	--	--	--	RD10361	--
			116	YAEV8C-L1	--	--	--	RD10711	--
			117	YAEV8C-L2	--	--	--	RD10721	--
			118	YAEV8C-L3	--	--	--	RD10731	--
#6	Blue	MS25036-	119	YAEV6C-L1-M	--	--	--	RE10261	--
			120	YAEV6C-L-M	--	--	--	RE10711	--
			121	YAEV6C-L4-M	--	--	--	RE10721	--
			122	YAEV6C-L2-M	--	--	--	RE10731	--

NOTE: Component manufactures' and OEM instructions shall take precedence over the information presented in these charts. Wire ranges are for reference only.

TBHD1M, HD120, HDE120B DIE/TOOL OPTIONS

HD120, HDE120B,
Hand Tool, p. 112-113
TBHD1M Hydraulic Tool, p. 112-113

HD36 TOOL SERIES OPTIONS

HD36 Hand Tool, p. 102
HDE36B Battery Tool, p. 103

HD51 TOOL SERIES OPTIONS

HD51 Hand Tool, p. 110-111
XHD51 Hydraulic Tool, p. 110-111
HDE51B Battery Tool - p. 110-111

DMC does NOT provide connectors, contacts, or wiring components. Parts are shown here for reference only. See disclaimer of liability on page 27.



Similar Terminal Shown

MS25036-123 TO -131, SIZES 4 TO 1

TYPE: Class 1 Insulated Terminals

INSULATION: Nylon, UL 94V-2

TERMINAL BODY & SLEEVE: Copper, ASTM B-152

PLATING: Tin, ASTM B-545

MAX TEMP RATING: 105° C

Tool Selection Guide

TERMINAL SPECS					DMC TOOL/DIE OPTIONS			
AWG	WIRE SIZE (MM)	INSULATION DIAMETER IN. (MM)	SLEEVE COLOR	TERMINAL/SPLICE PART NUMBER	HD002 SERIES DIE MIL-APPROVED (HEX)	HD51 SERIES DIE (HEX)	HD36 SERIES DIE (INDENT)	
#4	16.8 - 26.7	.430 (11.05)	Yellow	MS25036-	123	HD002-4	HD51-107	HD36-137
					124	HD002-4	HD51-107	HD36-137
					125	HD002-4	HD51-107	HD36-137
#2	26.7 - 42.4	.505 (12.83)	Red	MS25036-	126	HD002-2	HD51-113	--
					127	HD002-2	HD51-113	--
					128	HD002-2	HD51-113	--
#1	--	--	White	MS25036-	129	HD002-1	HD51-154	--
					130	HD002-1	HD51-154	--
					131	HD002-1	HD51-154	--

*QPL in Progress

Terminal Manufacturers' Part Numbers

TERMINAL SPECS			TERMINAL MANUFACTURERS' TERMINAL #						
AWG	SLEEVE COLOR	TERMINAL/SPLICE PART NUMBER	BURNDY	HOLLINGSWORTH	MOLEX	PANDUIT	THOMAS&BETTS	TYCO ELEC	
#4	Yellow	MS25036-	123	YAEV4C-L	--	--	--	RF10711	--
			124	YAEV4C-L4	--	--	--	RF10721	--
			125	YAEV4C-L2	--	--	--	RF10731	--
#2	Red	MS25036-	126	YAEV2C-L1	--	--	--	RG9711	--
			127	YAEV2C-L	--	--	--	RG9731	--
			128	YAEV2C-L4	--	--	--	RG9751	--
#1	White	MS25036-	129	YAEV1C-L1	--	--	--	RH9711	--
			130	YAEV1C-L	--	--	--	RH9731	--
			131	YAEV1C-L3	--	--	--	RH9751	--

NOTE: Component manufactures' and OEM instructions shall take precedence over the information presented in these charts. Wire ranges are for reference only.

TBHD1M, HD120, HDE120B DIE/TOOL OPTIONS

HD120, HDE120B,
Hand Tool, p. 112-113
TBHD1M Hydraulic Tool, p. 112-113

HD36 TOOL SERIES OPTIONS

HD36 Hand Tool, p. 102
HDE36B Battery Tool, p. 103

HD51 TOOL SERIES OPTIONS

HD51 Hand Tool, p. 110-111
XHD51 Hydraulic Tool, p. 110-111
HDE51B Battery Tool - p. 110-111

DMC does NOT provide connectors, contacts, or wiring components. Parts are shown here for reference only. See disclaimer of liability on page 27.



Similar Terminal Shown

MS25036-132 to -141, Sizes 1/0 to 4/0

TYPE: Class 1 Insulated Terminals

INSULATION: Nylon, UL 94V-2

TERMINAL BODY & SLEEVE: Copper, ASTM B-152

PLATING: Tin, ASTM B-545

MAX TEMP RATING: 105° C

Tool Selection Guide

TERMINAL SPECS					DMC TOOL/DIE OPTIONS			
AWG	WIRE SIZE (MM)	INSULATION DIAMETER IN. (MM)	SLEEVE COLOR	TERMINAL/SPLICE PART NUMBER	HD002 SERIES DIE MIL-APPROVED	HD51 SERIES DIE MIL-APPROVED (HEX)	HD36 SERIES DIE (INDENT)	
1/0	42.4-60.6	.632 (16.05)	Blue	MS25036-	132	HD002-01	--	
					133	HD002-01	--	
					134	HD002-01	--	
2/0	60.6-76.3	.684 (17.37)	Yellow	MS25036-	135	HD002-02	--	
					136	HD002-02	--	
					137	HD002-02	--	
3/0	76.3-96.3	.737 (18.72)	Red	MS25036-	138	HD002-03	--	
					139	HD002-03	--	
4/0	96.3-117	.799 (20.29)	Blue	MS25036-	140	HD002-04	--	
					141	HD002-04	--	

Terminal Manufacturers' Part Numbers

TERMINAL SPECS			TERMINAL MANUFACTURERS' TERMINAL #						
AWG	SLEEVE COLOR	TERMINAL/SPLICE PART NUMBER	BURNDY	HOLLINGSWORTH	MOLEX	PANDUIT	THOMAS&BETTS	TYCO ELEC	
1/0	Blue	MS25036-	132	YAEV25-L1	--	--	--	RJ9711	--
			133	YAEV25-L	--	--	--	RJ9731	--
			134	YAEV25-L3	--	--	--	RJ9751	--
2/0	Yellow	MS25036-	135	YAEV26-L2	--	--	--	RK9711	--
			136	YAEV26-L	--	--	--	RK9731	--
			137	YAEV26-L3	--	--	--	RK9751	--
3/0	Red	MS25036-	138	--	--	--	--	RL9731	--
			139	--	--	--	--	RL9751	--
4/0	Blue	MS25036-	140	--	--	--	--	RM9731	--
			141	--	--	--	--	RM9751	--

NOTE: Component manufactures' and OEM instructions shall take precedence over the information presented in these charts. Wire ranges are for reference only.

TBHD1M, HD120, HDE120B DIE/TOOL OPTIONS

HD120, HDE120B,

Hand Tool, p. 112-113

TBHD1M Hydraulic Tool, p. 112-113

DMC does NOT provide connectors, contacts, or wiring components. Parts are shown here for reference only. See disclaimer of liability on page 27.



Similar Terminal Shown

MS25036-143 to -151, Sizes 26 to 18

TYPE: Class 1 Insulated Terminals

INSULATION: Nylon, UL 94V-2

TERMINAL BODY & SLEEVE: Copper, ASTM B-152

PLATING: Tin, ASTM B-545

MAX TEMP RATING: 105° C

Tool Selection Guide*

TERMINAL SPECS					DMC TOOL/DIE OPTIONS					
AWG	WIRE SIZE (MM)	INSULATION DIAMETER IN. (MM)	SLEEVE COLOR	TERMINAL/SPLICE PART NUMBER	HX3 SERIES DIE MIL-APPROVED	HX4 SERIES DIE MIL-APPROVED (MULTI-CAVITY)	HX4 SERIES DIE MIL-APPROVED (SINGLE CAVITY)	HX4 SERIES (SINGLE CAVITY)	M22520/40-01 TOOL MIL-APPROVED	
#26-24	0.12 - 0.24	.082 (2.09)	Yellow	MS25036-	143	X511	Y501	Y1115*	Y672	AMT4001
					144	X511	Y501	Y1115*	Y672	AMT4001
					145	X511	Y501	Y1115*	Y672	AMT4001
					146	X511	Y501	Y1115*	Y672	AMT4001
					147	X511	Y501	Y1115*	Y672	AMT4001
#22-18	0.26-0.96	.125 (3.18)	Red	MS25036-	148	X511	Y501	Y1115*	Y672	AMT4001
					149	X511	Y501	Y1115*	Y672	AMT4001
					150	X511	Y501	Y1115*	Y672	AMT4001
					151	X511	Y501	Y1115*	Y672	AMT4001

*QPL in Progress, Die set includes insulation adjustment feature.

Terminal Manufacturers' Part Numbers

TERMINAL SPECS			TERMINAL MANUFACTURERS' TERMINAL #							
AWG	SLEEVE COLOR	TERMINAL/SPLICE PART NUMBER	BURNDY	HOLLINGSWORTH	MOLEX	PANDUIT	THOMAS&BETTS	TYCO ELEC	TYCO	
#26-24	Yellow	MS25036-	143	--	XR26336 N	--	--	RAX23	54310-1	--
			144	--	XR26337 N	--	--	RAX43	52189	--
			145	--	XR26338 N	--	--	RAX63	53073	--
			146	--	XR26339 N	--	--	RAX83	54311-1	--
			147	--	XR26340 N	--	--	RAX103	54321-1	54312-1
#22-18	Red	MS25036-	148	YAES18-N48	XR1880 SN	AA-820-04	PN18-4RN	RA323	31880	320553
			149	YAES18-N49	XR1890 SN	AA-821-08	PN18-8R	RA863	31890	320551
			150	YAES18-N50	XR1894 SN	AA-822-14	PN18-14R	RA713	31894	320551
			151	--	--	--	--	RA753	328975	--

NOTE: Component manufactures' and OEM instructions shall take precedence over the information presented in these charts. Wire ranges are for reference only.

HX4 TOOL SERIES OPTIONS FOR Y-DIES

HX4 Hand Tools, p. 90 & 91
 HXE4B Battery Tools, p. 92
 HX23 Pneumatic Tool, p. 94

HX3 TOOL SERIES OPTIONS FOR X-DIES

HX3 Hand Tools, p. 90 & 91

DMC does NOT provide connectors, contacts, or wiring components. Parts are shown here for reference only. See disclaimer of liability on page 27.



Similar Terminal Shown

MS25036-152 to -159, Sizes 22 to 10

TYPE: Class 1 Insulated Terminals

INSULATION: Nylon, UL 94V-2

TERMINAL BODY & SLEEVE: Copper, ASTM B-152

PLATING: Tin, ASTM B-545

MAX TEMP RATING: 105° C

Tool Selection Guide

TERMINAL SPECS					DMC TOOL/DIE OPTIONS					
AWG	WIRE SIZE (MM)	INSULATION DIAMETER IN. (MM)	SLEEVE COLOR	TERMINAL/SPLICE PART NUMBER	HX3 SERIES DIE MIL-APPROVED	HX4 SERIES DIE MIL-APPROVED (MULTI-CAVITY)	HX4 SERIES DIE (SINGLE CAVITY)	HX4 SERIES DIE (SINGLE CAVITY) (HEX)	M225220/40-01 TOOL MIL-APPROVED	
#16-14	1.04 - 2.62	.150 (3.81)	Blue	MS25036-	152	X511	Y501	Y1116*	Y671	AMT4001
					153	X511	Y501	Y1116*	Y671	AMT4001
					154	X511	Y501	Y1116*	Y671	AMT4001
					155	X511	Y501	YY1116*	Y671	AMT4001
#12-10	2.62 - 6.64	.230 (5.84)	Yellow	MS25036-	156	X515	Y501	Y1117*	Y670	--
					157	X515	Y501	Y1117*	Y670	--
					158	X515	Y501	Y1117*	Y670	--
#22-18	0.26-0.96	.230 (5.84)	Red	MS25036-	159	X511	Y501	Y1115*	Y672	AMT4001

*QPL in Progress, Die set includes insulation adjustment feature.

Terminal Manufacturers' Part Numbers

TERMINAL SPECS				TERMINAL MANUFACTURERS' TERMINAL #						
AWG	SLEEVE COLOR	TERMINAL/SPLICE PART NUMBER		BURNDY	HOLLINGSWORTH	MOLEX	PANDUIT	THOMAS&BETTS	TYCO ELEC	TYCO
#16-14	Blue	MS25036-	152	YAES14N52	--	BB-823-04	PN14-4R	RB1323	324159	--
			153	YAES14N53	XR1902 SN	BB-837-08	PN14-8R	RB863	51864-1	--
			154	YAES14N54	XR1906 SN	BB-825-14	PN14-14R	RB713	320563	--
			155	YAES14N55	--	--	--	RB753	328976	--
#12-10	Yellow	MS25036-	156	YAES10-N56	XR5108 N	C-828-08	PN10-8R	RC863	35108	320568
			157	YAES10-N57	XR5110 N	C-830-14	PN10-14R	RC713	35110	320569
			158	YAES10-N58	XR5117 N	--	--	RC753	--	--
#22-18	Red	MS25036-	159	--	XR1879 SN	AA-820-02	--	--	--	

NOTE: Component manufactures' and OEM instructions shall take precedence over the information presented in these charts. Wire ranges are for reference only.

HX4 TOOL SERIES OPTIONS FOR Y-DIES

HX4 Hand Tools, p. 90 & 91
 HXE4B Battery Tools, p. 92
 HX23 Pneumatic Tool, p. 94

HX3 TOOL SERIES OPTIONS FOR X-DIES

HX3 Hand Tools, p. 90 & 91

DMC does NOT provide connectors, contacts, or wiring components. Parts are shown here for reference only. See disclaimer of liability on page 27.

Installing and Removal Tools

DMC is dedicated to serving the connector tooling needs of the electronics industry. We, therefore, continue our connector product package with a wide variety of installing and removal tools.

Although we supply both plastic and metal tools, we recommend the use of the metal tools because of their durability.

When used properly they are more cost effective in that they withstand thousands of contact insertion and removal cycles. The trend to all metal tools is being actively encouraged by most departments of the government.

DMC installing and removal tools are of proven high quality and reliability. In addition to the tools listed in the reference table, we have many more for other connector applications. Consult DMC for details.

Illustrated on page 149 are typical rear and front release retention methods found in today's connectors.

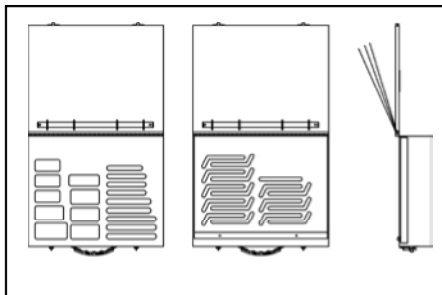

DMC1155 GENERAL PURPOSE INSERTION AND REMOVAL TOOL KIT

DMC's General Purpose Insertion and Removal Tool Kit contains metal insertion and removal tools for common Mil-Spec Circular Connectors, D-Subminiature Connector, ARINC Connectors and AS81714 terminal junctions. Consult DMC for further details.



AS81969 (M81969)/# REFERENCE CHART

MIL-81969/#	SUPERSEDED MILITARY #	MIL-81969/#	SUPERSEDED MILITARY #	MIL-81969/#	SUPERSEDED MILITARY #
1-01	MS3156-22	11-01	M28731/22-01	19-09	MS24256R12
1-02	MS3156-20 M24308/18-2	13-01	M28731/21-01	19-10	MS24256RH20
1-03	MS3156-16 M24308/18-3	14-01	MS27534-22D	19-11	MS24256RH16
1-04	M24308/18-1	14-02	MS27534-20 MS3447-20 M83723/31-20	20-01	MS17806
2-01	MS3323-22	14-03	MS27534-16 MS3447-16 M83723/31-16	27-01	MS90562-1
2-02	MS3323-20	14-04	MS27534-12 MS3447-12 M83723/31-12	27-02	MS90562-2
2-03	MS3323-16	15-01	MS3483-1	27-03	MS90562-3
2-04	MS3323-12	15-02	MS3483-2	27-04	MS90562-4
3-01	MS3344-23	15-03	MS3483-3	27-05	MS90562-5
3-02	MS3344-20	16-01	MS3160-20	27-06	MS90562-6
3-03	MS3344-16	16-02	MS3160-16	28-01	MS3178-001
3-04	MS3344-12	16-03	MS3160-12	28-02	MS3178-002
3-05	MS3342-23	16-04	MS3160-22	29-01	MS3165-16
3-06	MS3342-20	17-01	MS90455-16	29-02	MS3165-8 M83723/32-08
3-07	MS3342-16	17-02	MS90455-12	29-03	MS3165-4 M83723/32-04
3-08	MS3342-12	17-03	MS24256A20	29-04	MS3165-0 M83723/32-00
4-01	M55301/106-01	17-04	MS24256A16	30-01	MS3159-22
5-01	M55302/105-01	17-05	MS24256A12	30-02	MS3159-20
6-01	M21097/18-01	17-06	MS90455-8	30-03	MS3159-16
7-01	M21097/12-01	17-07	MS90455-4	30-04	MS3159-12
8-01	M55302/79-01 MS27495A22M	17-08	MS90455-0	30-05	MS3448-001A
8-02	M55302/79-02 MS27495R22M	18-01	MS17805	30-06	MS3448-001B
8-03	MS27495A22	19-01	MS90456-16	30-07	MS3448-001C
8-04	MS27495R22	19-02	MS90456-12	31-01	MS18137-20-1
8-05	MS27495A20	19-03	MS90456-8	31-02	MS18137-20-2
8-06	MS27495R20	19-04	MS90456-4	31-03	MS18137-20-3
8-07	MS27495A16	19-05	MS90456-0	31-04	MS18137-20-4
8-08	MS27495R16	19-06	MS24256R20	31-05	MS14035-02
8-09	MS27495A12	19-07	MS24256R20	31-06	MS14035-03
8-10	MS27495R12	19-08	MS24256R16	31-07	MS14035-01
9-01	M55302/18-01			31-08	MS14036-01
10-01	M55302/86-01			31-09	MS14036-02
				31-10	MS14036-03

DMC does not provide connectors, contacts or wiring components. Parts shown here are for reference only. See disclaimer of liability on page 27.

Installing and Removal Tool Illustrations

INSTALLING TOOLS

Straight (ILL. 1) and joggled tools (ILL. 2) hold contact and wire in line with center or side of the tool handle. Tool sizes are "0" to "24" gage. Handles are color coded aluminum. Tools range from 4 1/2" to 6" long with replaceable tips.

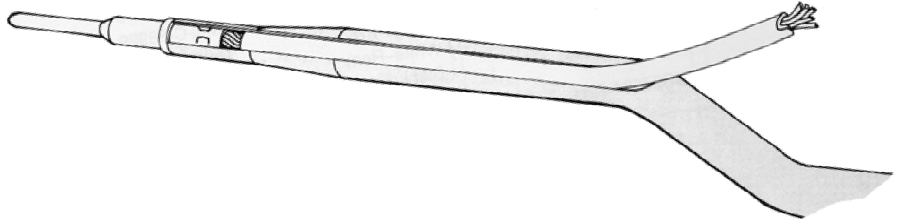
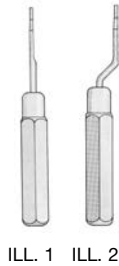

FRONT REMOVAL, REAR INSTALLING TOOLS

Both front removal (ILL. 3) and rear installing (ILL. 4) Military Standard tools offer a convenient and practical approach to servicing the MIL-C-81511, Series 1 & 2 connectors. Tools are color coded for contact size with half-inch hex metal handles.

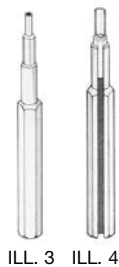

REAR REMOVAL AND INSTALLING TWEEZERS

Tools are for sizes 8 to 24 contacts. Used in NAS 1599, MIL-DTL-38999 and other rear release connectors.



REAR RELEASE PLIERS

This tool unlocks MIL-C-005015 contacts and sizes are 0, 4 and 8 gage.

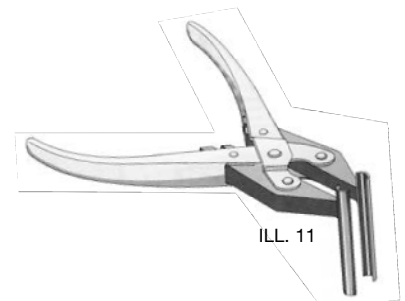

FRONT RELEASE

Front release connectors are easily serviced with these military spec removal tools. Handles are color coded for contact size. Replaceable tips are available.

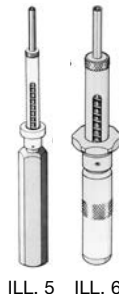

REF: MIL-C-005015, MIL-DTL-26482, MIL-C-26500, and MIL-C-26636 Connectors.

UNWIRED CONTACT TOOLS

Tool removes unwired contacts from connectors and is available in two styles. The metal style employs a locking wedge and removes contacts from terminal block as well as from the connectors.

The Military Standard tools use plastic probes which are interchangeable and available in sizes 12, 16, 20 (MS3448-001 kit) and 12 through 22 (MS3159), series NAS 1599 and MIL-C-81511, Series 3 and 4.

LONG-SLOT TOOLS

This long-slot tool illustrates the standard for MIL-C-005015 installing tools. Modified versions are available on request.

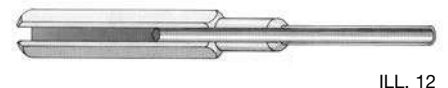

FRONT REMOVAL SPRING-LOADED PROBE CONTACT TOOLS (ILL. 7)



Employing the floating tip concept, these tools offer quality, as well as ease in operation. Body and handle are anodized aluminum alloy and color coded. Replaceable tips are available and require no special installing tools.

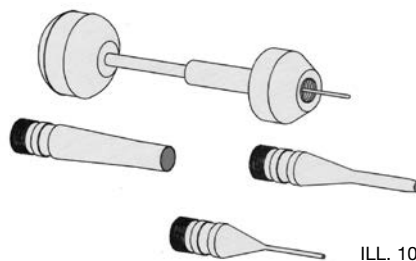

DMC does not provide connectors, contacts or wiring components. Parts shown here are for reference only. See disclaimer of liability on page 27.

AS81969 (M81969) Tool Part Number Guide

INSTALLING AND REMOVAL TOOLS				
MILITARY P/N	DMC P/N	INSTALLATION OR REMOVAL	SIZE	COLOR CODE
M81969/1-01	M81969/1-01	I/R	22	Green/White
M81969/1-02	M81969/1-02	I/R	20	Red/White
M81969/1-03	M81969/1-03	I/R	16	Blue/White
M81969/1-04	M81969/1-04	I/R	22D	Green/White
M81969/2-01	DAK126-23A	I	22	Yellow
M81969/2-02	DAK126-20A	I	20	Red
M81969/2-03	DAK126-16A	I	16	Blue
M81969/2-04	DAK126-12A	I	12	Yellow
M81969/3-01	DRK129-23A	R	23	Yellow
M81969/3-02	DRK129-20A	R	20	Red
M81969/3-03	DRK129-16A	R	16	Blue
M81969/3-04	DRK129-12A	R	12	Yellow
M81969/3-05	DRK125-23A	R	23	Yellow/Black
M81969/3-06	DRK125-20A	R	20	Red/Black
M81969/3-07	DRK125-16A	R	16	Blue/Black
M81969/3-08	DRK125-12A	R	12	Yellow/Black
M81969/8-01	DAK95-22MB	I	22D	Green
M81969/8-02	DRK95-22MB	R	22M	Green/White
M81969/8-03	DAK95-22B	I	22	Brown
M81969/8-04	DRK95-22B	R	22	Brown/White
M81969/8-05	DAK95-20B	I	20	Red
M81969/8-06	DRK95-20B	R	20	Red/White
M81969/8-07	DAK95-16B	I	16	Blue
M81969/8-08	DRK95-16B	R	16	Blue/White
M81969/8-09	DAK95-12B	I	12	Yellow
M81969/8-10	DRK95-12B	R	12	Yellow/White
M81969/8-205B	DAK83-20B	I	20	Red/Black
M81969/-206B	DRK83-20B	R	20	Red/White/Black
M81969/8-207	DAK83-16B	I	16	Blue/Black
M81969/8-208	DRK83-16B	R	16	Blue/White/Black
M81969/8-209	DAK83-12B	I	12	Yellow/Black
M81969/8-210	DRK83-12B	R	12	Yellow/White/Black
M81969/12-01	DRK248A	I/R	N/A	Straight
M81969/12-02	DRK246A	I/R	N/A	Angled
M81969/14-01	M81969/14-01	I/R	22D	Green/White
M81969/14-02	M81969/14-02	I/R	20	Red/White
M81969/14-03	M81969/14-03	I/R	16	Blue/White
M81969/14-04	M81969/14-04	I/R	12	Yellow/White
M81969/14-05	M81969/14-05	I/R	10	Grey/White
M81969/14-10	M81969/14-10	I/R	20	Red/Orange
M81969/14-11	M81969/14-11	I/R	20	Red/White
M81969/15-01	DRK250-8	R	8	None
M81969/15-02	DRK250-4	R	4	None
M81969/15-03	DRK250-0	R	1/0	None
M81969/16-01	81515-20	I/R	20	Red/White

INSTALLING AND REMOVAL TOOLS				
MILITARY P/N	DMC P/N	INSTALLATION OR REMOVAL	SIZE	COLOR CODE
M81969/16-02	81515-16	I/R	16	Blue/White
M81969/16-03	81515-12	I/R	12	Yellow/White
M81969/16-04	81515-23	I/R	22	Green/White
M81969/17-03	DAK20B	I	20	Red
M81969/17-04	DAK16B	I	16	Blue
M81969/17-05	DAK12B	I	12	Yellow
M81969/17-06	DAK55-8B	I	8	Red
M81969/17-07	DAK55-4B	I	4	Blue
M81969/17-08	DAK55-0B	I	0	Yellow
M81969/17-09	DAK83S-20	I	20	Red
M81969/18-01	DAK123A	I	16/20	Green
M81969/18-02	DAK123-22A	I	22	Gold
M81969/19-01	DRK16B	R	16	Blue
M81969/19-02	DRK12B	R	12	Yellow
M81969/19-03	DRK56-8B	R	8	Red
M81969/19-04	DRK56-4B	R	4	Blue
M81969/19-05	DRK56-0B	R	0	Yellow
M81969/19-06	DRK20B	R	20	Red
M81969/19-10	DHK20B	R	20	Red
M81969/19-11	DHK16B	R	16	Blue
M81969/20-01	DRK124A	R	16, 20	Green
M81969/20-02	DRK124-22A	R	22	N/A
M81969/21-01 (REF Only)	DHK368	I/R	16	N/A
M81969/27-01 (REF Only)	DRK178-1A	R	4/0	N/A
M81969/27-02 (REF Only)	DRK178-2A	R	2/0	N/A
M81969/27-03 (REF Only)	DRK178-3A	R	1/0	N/A
M81969/27-04 (REF Only)	DRK178-4A	R	2	N/A
M81969/27-05 (REF Only)	DRK178-5A	R	4	N/A
M81969/27-06 (REF Only)	DRK178-6A	R	6	N/A
M81969/28-01 (REF Only)	DRK310	R	COAX	N/A
M81969/28-02 (REF Only)	DRK337	R	COAX	N/A
M81969/29-01 (REF Only)	CIET16-9	R	18	Blue
M81969/29-02 (REF Only)	CIET8-2	R	8	Red
M81969/29-03 (REF Only)	CIET4-8	R	4	Blue
M81969/29-04 (REF Only)	CIET0-1	R	0	Yellow
M81969/33-01	DAK55-22SA	I/R	22	Red
M81969/33-02	DAK55-22JA	I/R	22	Red
M81969/34-01	DRK56-22A	R	22	Red
M81969/39-01	M81969/39-01	I/R	20	Green/White

AS81969 (M81969) Tool Part Number Guide

PLASTIC UNWIRED AND BROKEN WIRE REMOVAL TOOLS						
MILITARY P/N (HANDLE W/ PROBE)	DMC P/N	MILITARY P/N (PLASTIC PROBE ONLY)	DMC P/N (PLASTIC PROBE ONLY)	PROBE COLOR	PROBE BAND COLOR	CONTACT SIZE
M81969/30B-01 Rev B	DRK501B	M81969/30B-21	DRK521B	YELLOW	BLACK	22
M81969/30B-02 Rev B	DRK502B	M81969/30B-22	DRK522B	RED	BLACK	20
M81969/30B-03 Rev B	DRK503B	M81969/30B-23	DRK523B	BLUE	BLACK	16
M81969/30B-04 Rev B	DRK504B	M81969/30B-24	DRK524B	YELLOW	BLACK	12
M81969/30B-05 Rev B	DRK505B	M81969/30B-25	DRK525B	RED	SILVER	20
M81969/30B-06 Rev B	DRK506B	M81969/30B-26	DRK526B	BLUE	SILVER	16
M81969/30B-07 Rev B	DRK507B	M81969/30B-27	DRK527B	YELLOW	SILVER	12
M81969/30B-08 Rev B	DRK508B	M81969/30B-28	DRK528B	BROWN	BROWN	22D
M81969/30B-09 Rev B	DRK509B	M81969/30B-29	DRK529B	YELLOW	BROWN	22M
M81969/30B-10 Rev B	DRK510B	M81969/30B-30	DRK530B	GREEN	BROWN	22
M81969/30B-11 Rev B	DRK511B	M81969/30B-31	DRK531B	RED	BROWN	20
M81969/30B-12 Rev B	DRK512B	M81969/30B-32	DRK532B	BLUE	BROWN	16
M81969/30B-13 Rev B	DRK513B	M81969/30B-33	DRK533B	YELLOW	BROWN	12
M81969/30B-14	DRK514B	M81969/30B-37	DRK537B	BLACK	BROWN	10
M81969/30B-19 Rev B (TOOL SET)	DRK519B	--	--	--	--	10 THRU 22M
M81969/30B-35 Rev B (TOOL SET)	DRK535B	--	--	--	--	20 THRU 12
M81969/30B-36 Rev B (TOOL SET)	DRK536B	--	--	--	--	22D, 22M THRU 10
M81969/30B-20 Rev B (HANDLE FOR PLASTIC PROBES)	DRK520B	--	--	--	--	10 THRU 22M

METAL UNWIRED AND BROKEN WIRE REMOVAL TOOLS						
MILITARY P/N (HANDLE W/ PROBE)	DMC P/N	MILITARY P/N (METAL PROBE ONLY)	DMC P/N (METAL PROBE ONLY)	PROBE COLOR	PROBE BAND COLOR	CONTACT SIZE
M81969/30B-08M Rev B	DRK276-22D	M81969/30B-28M	DRK725	METALLIC	BROWN	22D
M81969/30B-09M Rev B	DRK276-22M	M81969/30B-29M	DRK726	METALLIC	YELLOW	22M
M81969/30B-10M Rev B	DRK276-22	M81969/30B-30M	DRK727	METALLIC	GREEN	22
M81969/30B-11M Rev B	DRK276-20	M81969/30B-31M	DRK728	METALLIC	RED	20
M81969/30B-12M Rev B	DRK276-16	M81969/30B-32M	DRK729	METALLIC	BLUE	16
M81969/30B-13M Rev B	DRK276-12	M81969/30B-33M	DRK730	METALLIC	YELLOW	12
M81969/30B-14M Rev B	DRK276-10	M81969/30B-37M	DRK731	METALLIC	BLACK	10
M81969/30B-40M Rev B (TOOL SET)	DRK540B	--	--	--	-	22D, 22M THRU 10
M81969/30B-20M Rev B (METAL HANDLE FOR METAL PROBES)	DRK520MB	--	--	--	-	10 THRU 23

TYPICAL FRONT RELEASE CONTACT

TYPICAL REAR RELEASE CONTACT

AS81969 (M81969) Tool Part Number Guide

PLASTIC TOOL APPLICATION (CONNECTOR SERIES/PART NUMBERS)

MIL-DTL-24308, & SAE AS81659 SERIES II			
CONTACT SIZE	TOOL PART NO.	COLOR/COMPOSITION	COMPARABLE METAL TOOLS*
22	M81969/1-01	GREEN/WHITE – PLASTIC BODY, METAL TIPS	DAK266J & DRK266J
20	M81969/1-02	RED/WHITE – PLASTIC BODY, METAL TIPS	DAK 145 & DRK145
16	M81969/1-03	BLUE/WHITE – PLASTIC BODY, METAL TIPS	DAK83-16B & DRK83-16B
22D	M81969/1-04	GREEN/WHITE – PLASTIC BODY, METAL TIPS	DAK95-22MB & DRK95-22MB
MIL-DTL-38999, MIL-DTL-55302/68 & /69, MIL-DTL-24308 (SIZE 22D ONLY), MIL-DTL.83733 (SIZE 22D ONLY), & AS81714 (SIZE 22D ONLY)			
23	M81969/1-05	BLACK/WHITE – PLASTIC BODY, METAL TIPS	DAK95-23 & DRK95-23
22D, 22M	M81969/14-01	GREEN/WHITE – ALL PLASTIC	DAK95-22MB & DRK95-22MB
22	M81969/14-09	BROWN/WHITE – ALL PLASTIC	DAK95-22B & DRK95-22B
20	M81969/14-10	RED/ORANGE – ALL PLASTIC	DAK95-20B & DRK95-20B
16	M81969/14-03	BLUE/WHITE – ALL PLASTIC	DAK95-16B & DRK95-16B
12	M81969/14-04	YELLOW/WHITE – ALL PLASTIC	DAK95-12B & DRK95-12B
10	M81969/14-05	GRAY/WHITE – ALL PLASTIC	DAK95-10B & DRK95-10B
8	M81969/14-08	RED – ALL PLASTIC (REMOVAL ONLY)	DRK95-08B
MIL-DTL-26482 SERIES II, SAE AS81703, SERIES III, MIL-DTL-83733 (EXCEPT 22D), MIL-DTL-83723 (SERIES II & III), AS50151 (AS3450 ONLY), & AS81714 (EXCEPT SIZE 22D)			
20	M81969/14-11	RED/WHITE – ALL PLASTIC	DAK83-20B & DRK83-20B
16	M81969/14-03	BLUE/WHITE – ALL PLASTIC	DAK83-16B & DRK83-16B
12	M81969/14-04	YELLOW/WHITE – ALL PLASTIC	DAK83-12B & DRK83-12B
8	M81969/14-06	RED – ALL PLASTIC (REMOVAL ONLY)	DRK250-8
4	M81969/14-07	BLUE – ALL PLASTIC (REMOVAL ONLY)	DRK250-4
0	M81969/14-08	YELLOW – ALL PLASTIC (REMOVAL ONLY)	DRK250-0
SAE AS50151 (REAR RELEASE), SAE AS3450, SERIES III, MIL-DTL-83733 (EXCEPT 22D), MIL-DTL-83723 (SERIES II & III), AS50151 (AS3450 ONLY), & AS81714 (EXCEPT SIZE 22D)			
16	M81969/29-01	BLUE – ALL PLASTIC (REMOVAL ONLY)	DRK83-16B
8	M81969/29-02	RED – ALL PLASTIC (REMOVAL ONLY)	DRK250-8
4	M81969/29-03	BLUE – ALL PLASTIC (REMOVAL ONLY)	DRK250-4
0	M81969/29-04	YELLOW – ALL PLASTIC (REMOVAL ONLY)	DRK250-0
MIL-DTL-24308 SIZE 20 ONLY			
20	M81969/39-01	GREEN/WHITE – ALL PLASTIC	DAK 145 & DRK145

*ANGLED METAL TWEEZER TOOLS LISTED. IN-LINE AND JOGGLED TIP TOOLS AVAILABLE. CONSULT DMC FOR DETAILS.

Plastic and Metal Insertion and Removal Tools

PLASTIC TOOLS VS. DMC METAL TOOLS

Plastic Insertion and Removal Tools are common throughout the aerospace wire harness industry, and they are required to be packaged and supplied with many of the rear release MIL-SPEC connectors which are supplied with contacts.

Metal tools are readily available for all applications where all plastic and plastic/metal tools are specified. DMC stands by the commitment to our customers that we manufacture and supply the most durable and functional assembly/disassembly tooling available. This is another area of our product line where that commitment pays off, and allows the users many options for their best tooling choice.

All metal insertion and removal tools are durable, and if used properly, the all metal tools are less likely to cause damage to connector sealing grommets, or slow the assembly process of connectors and similar wiring components in production wire shops.

DISADVANTAGES OF PLASTIC TOOLS

The complete insertion/locking of the contact into the connector requires a firm push, in-line with the multiple contact retention tines (gripping latches which hold the contact into the connector). The strength and stability of plastic tools is a compromise to the requirement of having all contact retention tines locked around the contact shoulder. The DMC all metal insertion tools have the strength and stability to fully insert and lock the contact into its cavity.

The primary root causes of contact retention failures is partially inserted contacts, due to the use of flexible plastic tools, or inserting contacts into a connector with no insertion tool (push with the wire only).

Please refer to the tables on page 56 for the recommended all metal insertion and removal tools for common MIL-SPEC connectors and contacts. There are options for all metal tools not shown in the chart. DMC stocks and provides all plastic, plastic/metal, and all metal insertion and removal tools of many types. Please feel free to contact DMC to learn about all the insertion/removal tool options for your particular wiring applications.

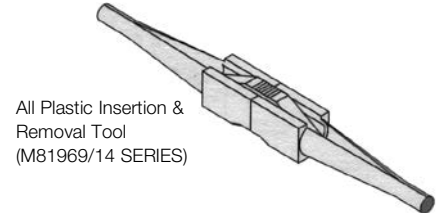

All Plastic Insertion & Removal Tool (M81969/14 SERIES)

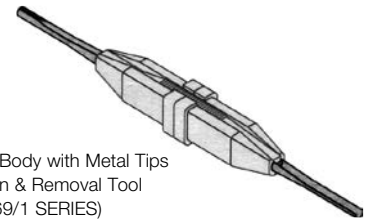

Plastic Body with Metal Tips Insertion & Removal Tool (M81969/1 SERIES)

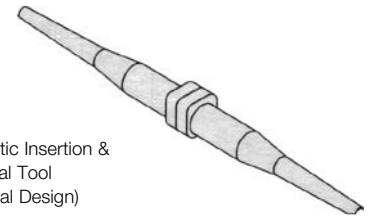

All Plastic Insertion & Removal Tool (Optional Design)

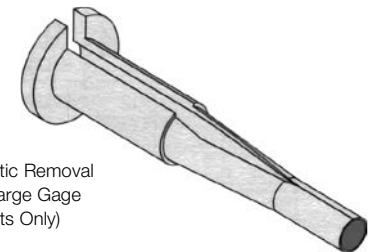

All Plastic Removal Tool (Large Gage Contacts Only)

Typical All Plastic Tool Operation

Typical All Metal Tool Operation

Unwired Contact Removal Tools (M81969/30)

PLASTIC-PROBE UNWIRED CONTACT REMOVAL TOOLS

Removing unwired contacts can be difficult. It is very important not to damage the interfacial seal and/or connector insert when removing unwired contacts.

M81969/30 Series Plastic Probe Tools are ideal for removing unwired contacts from connectors. As the plastic probe slides into the connector, it disengages the contact lock - ing mechanism and stretches over the contact, gripping it securely in the plastic probe.

Different colored tool probes and probe bands are used to distinguish between series and contact sizes.



PLASTIC-PROBE UNWIRED CONTACT REMOVAL TOOLS					
TOOL PART NUMBER	CONNECTOR SERIES	PROBE PART NUMBER	PROBE SIZE	PROBE COLOR	PROBE BAND COLOR
DRK105	MIL-DTL-38999 Series 1 - 4 MIL-DTL-24308 MIL-DTL-55302/68 MIL-DTL-55302/71 MIL-DTL-55302/75 MIL-DTL-83733 (size 22D only)	DRK105-22D-2	22D	Brown	Brown
		DRK105-22M-2	22M	Yellow	Brown
		DRK105-22-2	22	Green	Brown
		DRK105-20-2	20	Red	Brown
		DRK105-16-2	16	Blue	Brown
		DRK105-12-2	12	Yellow	Brown
DRK110	MIL-DTL-83733 (except size 22D) MIL-DTL-83723 Series 3 MIL-DTL-26482 Series 2 MIL-C-81511 (class "L" only)	DRK110-20-2	20	Red	Silver
		DRK110-16-2	16	Blue	Silver
		DRK110-12-2	12	Yellow	Silver
DRK130	MIL-C-81511 Series 3 & 4	DRK130-22-2	22	Yellow	Black
		DRK130-20-2	20	Red	Black
		DRK130-16-2	16	Blue	Black
		DVZK130-12-2	12	Yellow	Black
DRK150	AS50151 Series MS3450	DRK50	20	Red	Green
		DRK50-16-2	16	Blue	Green
		DRK50-12-2	12	Yellow	Green

METAL-PROBE UNWIRED CONTACT AND BROKEN WIRE REMOVAL TOOLS

When a wire breaks inside the connector the remaining wire strands can damage the plastic tips of DMC's standard unwired contact removal tools. To solve this problem, DMC engineered the DRK276 series of metal tip removal tools for removing broken wire contacts.

Instead of different colored probes and bands, the DRK276 series removal tools have different colored tool bodies to help distinguish between tip sizes.

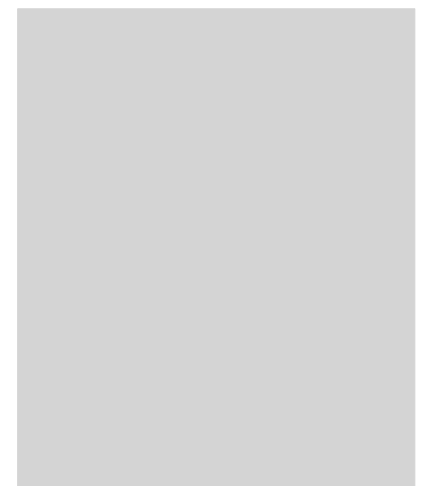

METAL-PROBE UNWIRED CONTACT REMOVAL TOOLS			
CONNECTOR SERIES	TOOL PART NUMBER	PROBE SIZE	BODY COLOR
MIL-DTL-38999 Series 1 - 4	DRK276-12	12	Yellow
	DRK276-16	16	Blue
	DRK276-20	20	Red
	DRK276-22	22	Brown
	DRK276-22M	22M	Green
	DRK276-22D	22D	Black

Wire Harness Tools

WIRE HARNESS SPOON

DMC's Wire Harness Spoon is used to assist in inserting new wires into existing wire harnesses. It helps thread new or repaired wires under tight cable ties, zip ties, string ties and cushion clamps.

The plastic construction of the wire harness spoon reduces damage when inserting wires because it will not damage ties or adjacent wires. There is less chance of nicks or cuts than with a metallic wire harness spoon. It can also be used to isolate cable ties for safe cutting to prevent damage to wire insulation.

The **WHS-1** is Orange in color and .875" wide by 6" long.

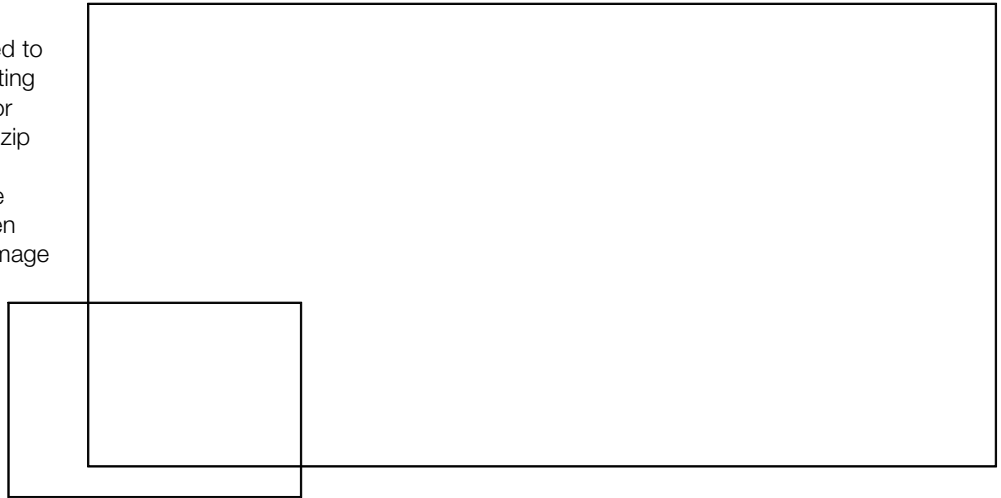

CABLE TIE REMOVAL TOOL

Now you can quickly remove cable ties without damaging the wire harness. The safety guards on the tip of the MG cable tie removal tools slide behind the cable tie strap to prevent the sharp blades from contacting and damaging the bundled items. The ergonomic, cushion grip handles and scissor action produce a clean cut.

Also use the MG series cable tie removal tools when repairing and retrofitting wire harnesses and hose assemblies, removing packaged items, prototyping and testing products, and many other factory and field uses.

These cable tie removal tools provide a long life when cutting plastic, thin copper wire, and aluminum wire AWG 10 and smaller. Each tool is made of heat treated alloy steel with a Rockwell hardness range of 53-58Rc.

PART NUMBER	CUTS CABLE TIE SIZES	TOOL LENGTH	TOOL WIDTH	DESCRIPTION
MG-1300	18 lb. to 250 lb.	6.49"	2.35"	Short Handle Length with Pointed Nose for Tight Spaces

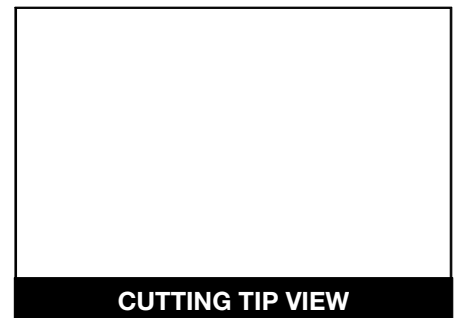
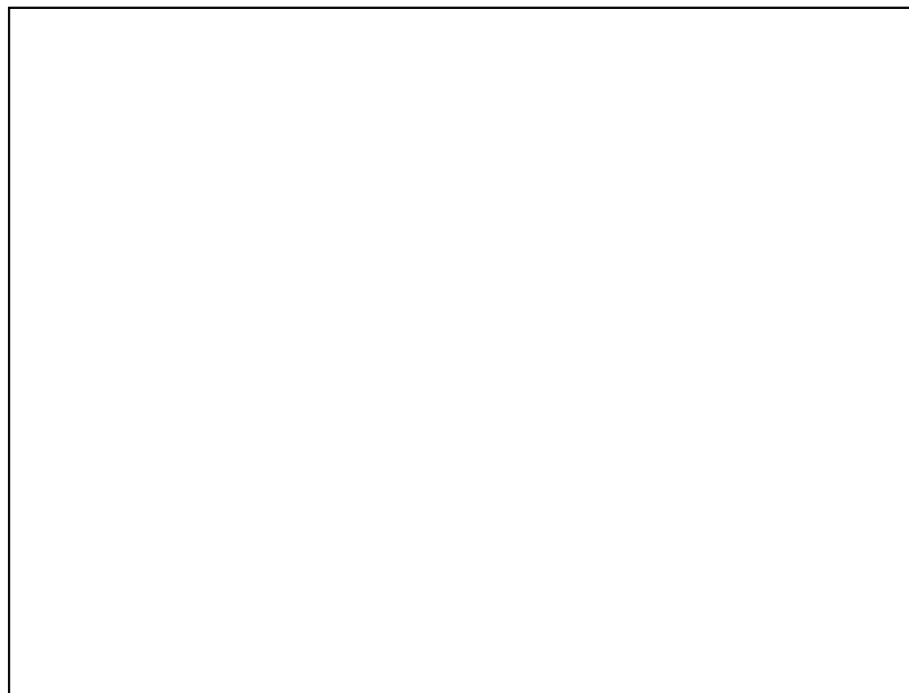

Contact Retention Test Tools

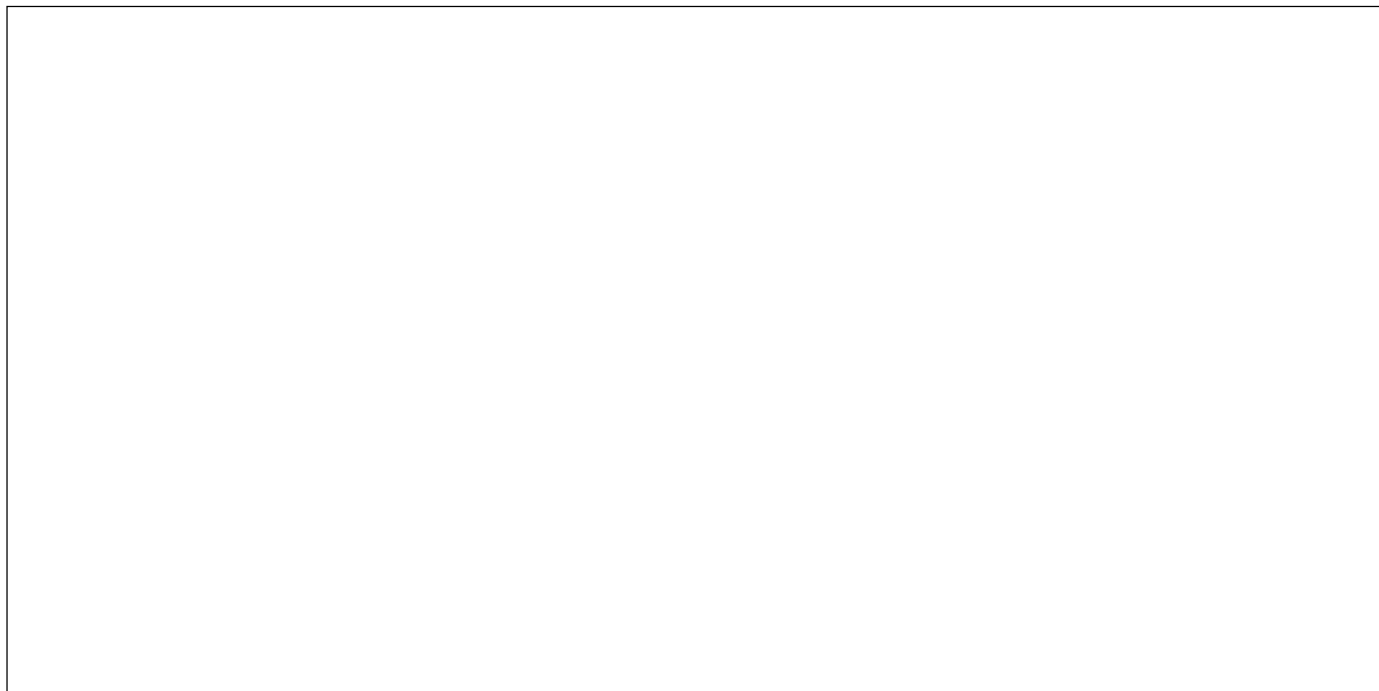

Typical application showing tool testing pin contacts.

The quality assurance test most often overlooked is retention (proper seating of contacts). This important test can now be performed simply and in a matter of seconds with the DMC retention testing tools.

These tools are for checking the retention of pins and sockets in electrical connectors. The tester pin and socket tips are aluminum. All tips are replaceable. A nylon hand protector is provided with each tool. The tools can be preset at the factory to your request.

Insert tester into or over a contact so that the tester and contact are in a straight line. Hold in this position throughout the test. Use pin end with a socket contact and the socket end with a pin contact.

Apply pressure to tester until the indicator band is covered by the slide. If contact is still firmly retained, the retention is satisfactory.

TOOL PART NUMBER	RANGE POUNDS
HT250-1	1.5 THRU 3.0
HT250-2*	3.0 THRU 5.5
HT250-3	4.0 THRU 8.0
HT250-4	7.0 THRU 18.0
HT250-5	17.0 THRU 25.0
HT250-6	24.0 THRU 40.0

Notice: The above part numbers apply to retention tools only (less tips). All tips must be purchased under separate part number.

**The H250-2 is the preferred tool*

CONTACT SIZE	COLOR CODE	SOCKET TESTER	PIN TESTER
4	Yellow	67-004-01	68-004-01
6	Blue	67-006-01	68-006-01
8	Red	67-008-01	68-008-01
10	Gray	67-010-01	68-010-01
12	Yellow	67-012-01	68-012-01
16	Blue	67-016-01	68-016-01
20	Red	67-020-01	68-020-01
22, 22M, 22D	Copper	67-022-01	68-022-01
23	Black	67-023-01	68-023-01
24	Gold	67-024-01	68-024-01
26	Green	67-026-01	68-026-01

DMC recommends that the lightest pressure be used to test proper installation of electrical contacts. Three to five pounds is adequate to test most installed contacts. Additional information is available. Please consult DMC.

Contact Retention Calibration Equipment and Gages

CONTACT RETENTION TEST TOOL CALIBRATION EQUIPMENT

The **RTCG-75A** Retention Tester Calibration Gage is supplied to support in-house calibration of DMC **HT250** Series Retention Testers. It incorporates the latest Alphasatron™ digital test technology, and is self-contained and portable.

The tester is supplied in a protective case with calibration certificate to NIST (accuracy 0.5% full scale to 75 pounds force).

Contact Gages

CONTACT GAGES

Contact Gages are used to determine the size of a contact's mating end (sizes 12-22) which then aids in selecting the proper installation and/or removal tooling.

Gage size of a contact is determined by matching a contact gage with the contact mating end and noting the size of the best fitting gage. To gage pins, start with the smallest gage and work your way up the scale; the first gage that fits over the pin is the size of that pin. To gage sockets, start with the largest gage and work your way down the scale; the first gage that fits inside the socket is the size of that socket.

The gage sizes are stamped on the tool and all contact gages are color coded for correct size identification. The gage end used for measuring socket contacts is marked with an "S". And the gage end used for measuring pin contacts is marked with a "P".

CAUTION: These tools are not to be used as a pin straightener.

P/N	SIZE	COLOR
CG10	10	GRAY
CG12	12	YELLOW
CG16	16	BLUE
CG20	20	RED
CG22	22	BRONZE
CG23	23	BLACK

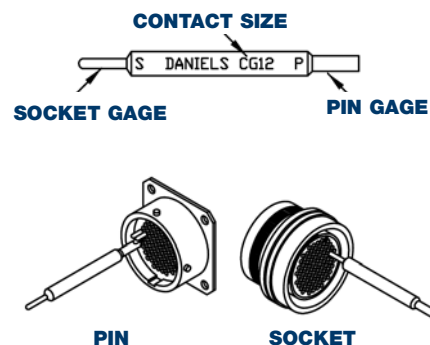

Connectors may contain several different size contacts.

BETA Backshell Accessory Torque Tools

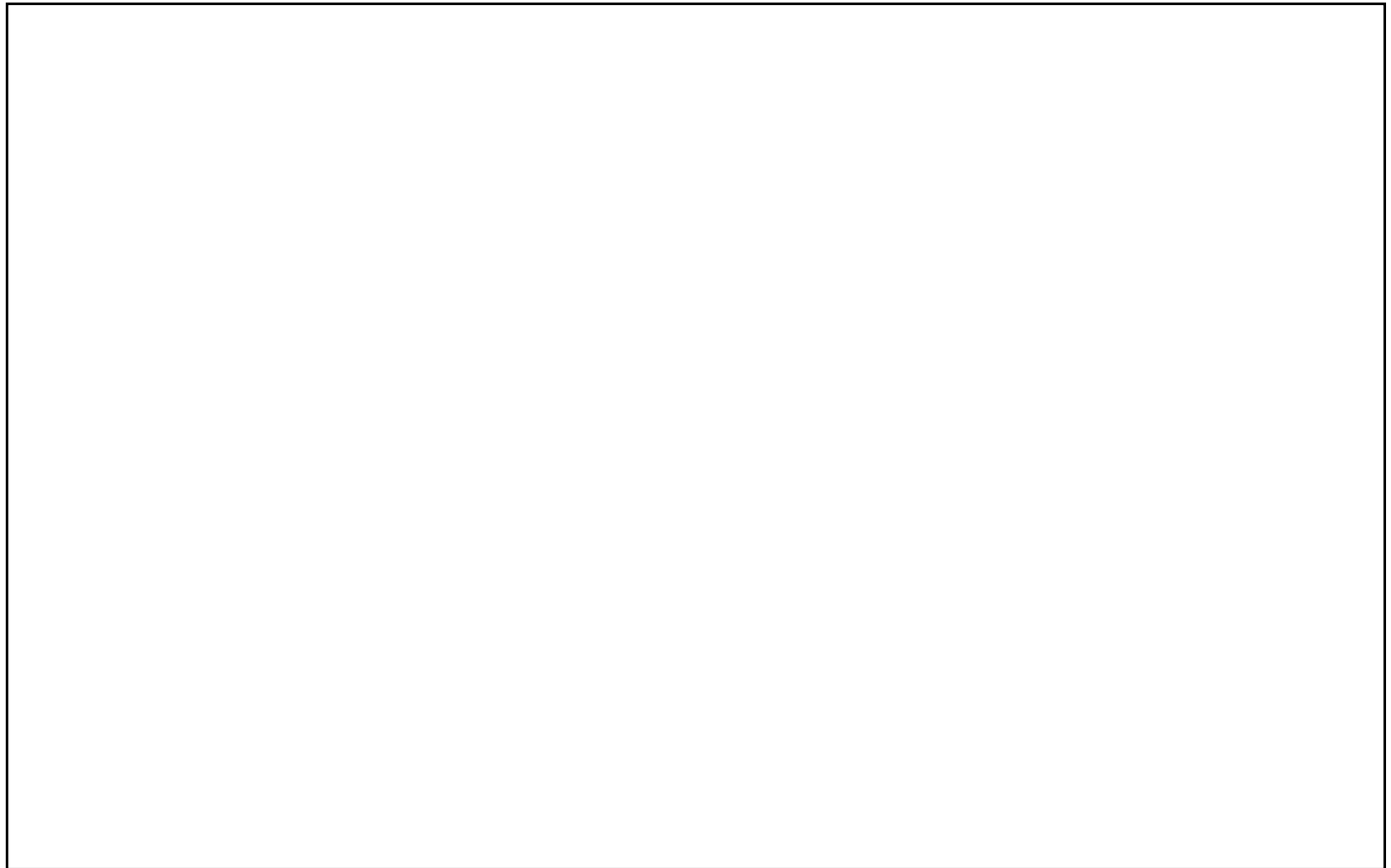

DMC offers a complete line of Adaptor Tools and Torque Tools for holding and torquing circular connectors during the installation and removal of accessories (backshell, strain relief, or EMI/RFI shielding hardware).

The evolution of circular connectors has produced many mechanical configurations which have more precise dimensional tolerances and electrical characteristics than any other mechanical

component used in modern electrical systems. The associated tooling must meet the same level of precision to apply the connector to its intended purpose. Until now, very little attention has been focused on the tooling which is used to mount strain-relief backshells and other accessories to wired connector assemblies. This is why the BETA Connector Mate® system was developed.

This unique concept is based upon adaptor tools which are configured to mate with a specific connector series and shell size regardless of keying arrangement. They may be used simply as hand holding devices for easy tightening, or, for more exact requirements. DMC offers a wide variety of circular wrenches, strap wrenches, torque meters, and vises which can be used in a variety of combinations.

Additional catalog information is available, contact DMC

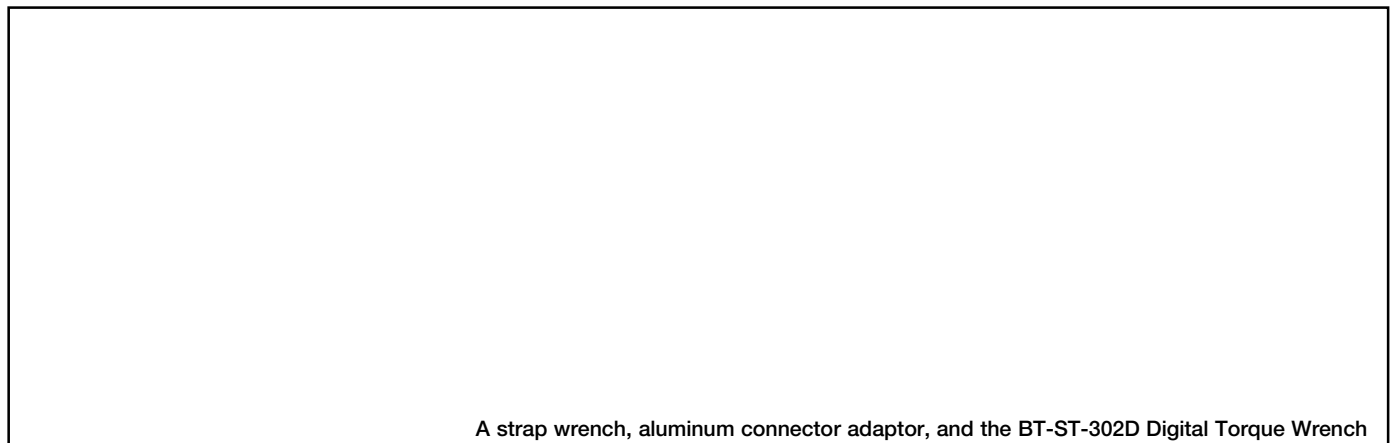

A strap wrench, aluminum connector adaptor, and the BT-ST-302D Digital Torque Wrench

BETA Backshell Tool Sets

Quick Reference Guide

QUICK REFERENCE TOOLING GUIDE

CONNECTOR IDENTIFICATION	ADAPTOR TOOL SETS		ADAPTOR LABEL	PAGE
	PLUG	RECEPTACLE		
AS50151 (MIL-C-5015)	CM-S-5015	CM-S-5015R	CHROME	6
MIL-DTL-22992 CLASS C,J,R	CM-S-229	N/A	BROWN	7
MIL-DTL-22992 CLASS L	CM-S-229L	N/A	BLACK	8
MIL-DTL-26482 SERIES I & II	CM-S-264	CM-S-264R	ORANGE	9
MIL-DTL-26500	CM-S-837	CM-S-837RB*	GREEN	10
MIL-DTL-28840	CM-S-288	CM-S-288R	WHITE	11
MIL-DTL-38999 SERIES I	CM-S-389L	CM-S-389LR	BLUE	12
MIL-DTL-38999 SERIES II	CM-S-389S	CM-S-264R	GRAY/ ORANGE	13
MIL-DTL-38999 SERIES III	CM-S-389T	CM-S-389TR	LAVENDER	14
MIL-DTL-38999 SERIES IV	CM-S-389B	CM-S-389BR	BEIGE	15
MIL-C-81511 SERIES I & III	CM-S-815L	CM-S-815R	YELLOW	16
MIL-C-81511 SERIES I & IV	CM-S-815S	CM-S-815R	RED	17
MIL-DTL-83723 SERIES I	CM-S-264	CM-S-264R	ORANGE	18
MIL-DTL-83723 SERIES II	CM-S-5015	CM-S-5015R	CHROME	19
MIL-DTL-83723 SERIES III*	CM-S-837	CM-S-837RB*	GREEN	20
PATTERN 602	CM-S-602	CM-S-264R	PURPLE	21
PATTERN 615	CM-S-SJT	CM-S-264R	GOLD	22

*Bayonet Couplings Only – Threaded receptacle adaptor sets are not available.
 MATERIAL: ALUMINUM STEEL TOOLING IS AVAILABLE. CHECK WITH DMC FOR DETAILS.
 NA - (Not available at time of printing – consult DMC)

SIMPLE ORIENTATION TO THE CONNECTOR

All adaptor tools have an indicator (Dot) which visually orients it with the master key on the connector. This enables the user to orient the two components for mating without trial and error fumbling.

ECONOMICAL, RELIABLE, AND AVAILABLE

There is not a precision system for holding circular connectors available anywhere which is more economical, reliable, or readily available to meet your needs than the DMC Beta adaptor tools.

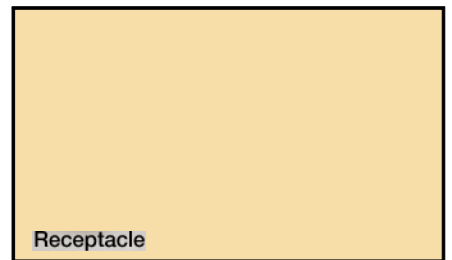

Typical Mated Pair Connectors

A Reverse Head Model is Also Available, Part Number BT-ST-302DR

Complete Backshell tooling guide available. Please consult DMC for details.

A Bench Mount is Also Available, Part Number BM-302D

EMI/RFI Band Application System for M85049/128 Shield Termination Bands

EMI/RFI Band Application System

The termination of EMI/RFI shielding materials is a specialized science in today's aerospace wiring systems. Application tooling is a critical factor in the overall performance of the wiring system components. DMC has worked closely with the world's leading connector accessory manufacturers and standards organizations to develop the necessary tooling and accessories to meet the stringent demands of aerospace and defense system contractors. The resulting products afford the user a repeatable and reliable means of terminating shielding on aerospace wiring systems. Tooling is available for all bands qualified to AS85049/128.

M81306/1 SERIES ONE-STEP BANDING TOOL

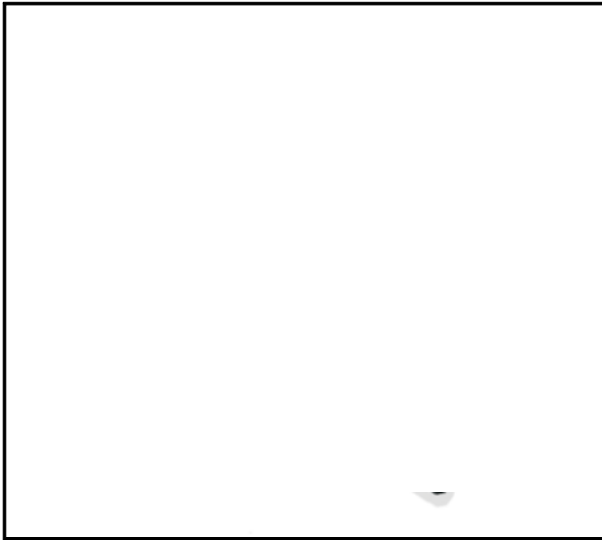

DMC's One-Step Banding Tools are designated for **M85049/128-3**, **M85049/128-4**, **M85049/128-7** and **M85049/128-8** "stamped buckle" bands. These tools tension, bend, and cut the band in one operation.

(See pages 164-166 for available tool and accessory combinations)

DBS-2100 is the .250 Wide Band Application Tool **M81306/1A**
DBS-2200 is the .125 Wide Mini-Band Application Tool **M81306/1B**

One-Step Tool Application

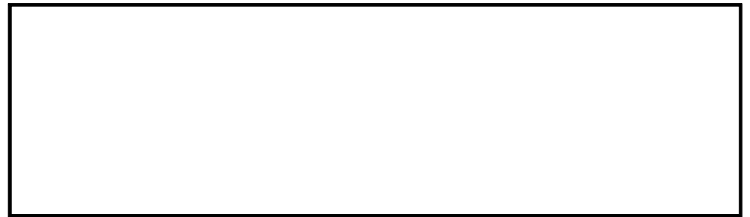

Stamped Buckle Band (Band style must be matched to tool. See next page for part number association)

M81306/2 SERIES TWO-STEP BANDING TOOLS

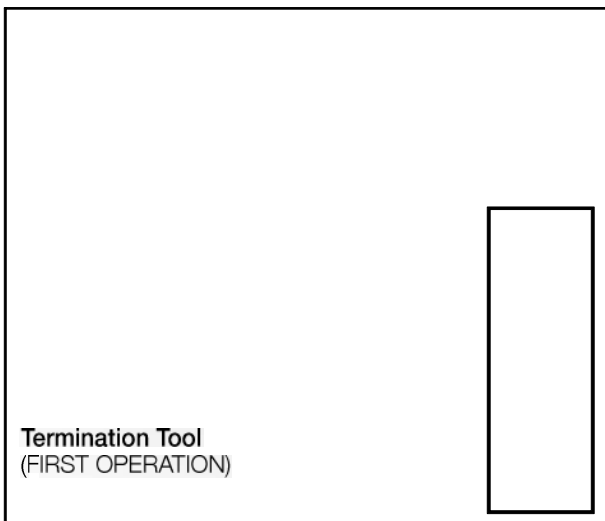

Termination Tool
(FIRST OPERATION)

Roll Over Tool
(SECOND OPERATION)

DMC's Two-Step Banding Tools are designated for **M85049/128-1**, **M85049/128-2**, **M85049/128-5** and **M85049/128-6** "welded buckle" bands. These tools tension and cut the band and leave an extended cut off tab. The second step provides an extra level of security by utilizing a roll-over tool to bend the cut-off tab over a full 180 degrees in a second operation.

DBS-1100 .250 Wide Band Application Tool **M81306/2-01A**
DBS-1200 .125 Wide Mini-Band Application Tool **M81306/2-02B**

Two-Step Tool Application



M85049/128 Band Configurations



NOTE: Always install M85049/128-X bands with 2 layers of band through the buckle.

M85049/128 Shield Termination Bands are available in two distinct configurations, Stamped and Welded Buckles, and two different widths, .250 in. (6.350 mm) and .125 in. (3.175 mm). The bands come flat or pre-coiled and ready for use.

The buckle for the **M85049/128-3**, **M85049/128-4**, **M85049/128-7**, and **M85049/128-8** bands is a STAMPED buckle. This configuration is low-profile style with a slot for the other end of the band to pass through.

The buckle for the **M85049/128-1**, **M85049/128-2**, **M8549/128-5**, and **M85049/128-6** bands is a WELDED buckle. This configuration is folded style with a loop for the other end of the band to pass through.

Quick Reference Guide: Band Part Number to Installation Tool*			
M85049/128-1	2 Step Tool	M85049/128-5	2 Step Tool
M85049/128-2	2 Step Tool	M85049/128-6	2 Step Tool
M85049/128-3	1 Step Tool	M85 049/128-7	1 Step Tool
M85049/128-4	1 Step Tool	M85049/128-8	1 Step Tool

*See pages 164-166 for full details.

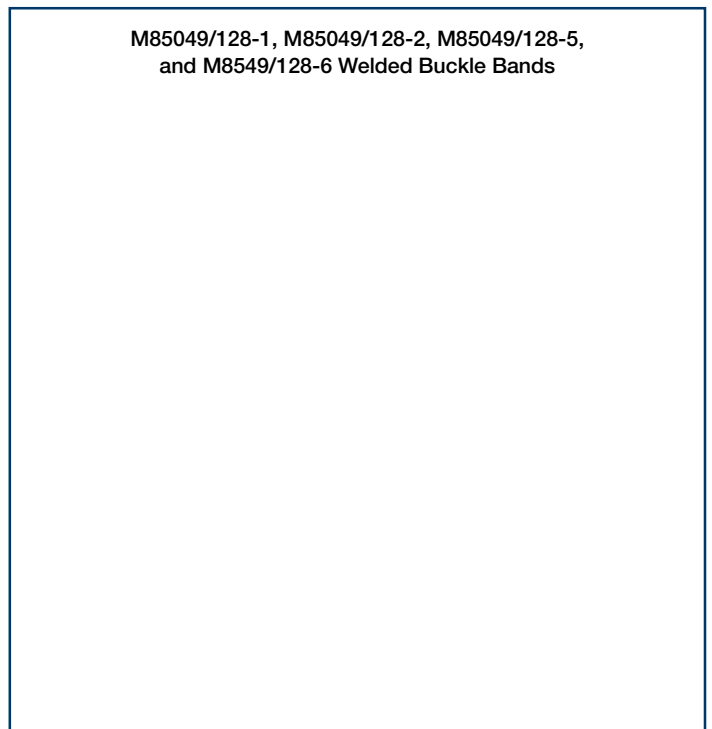
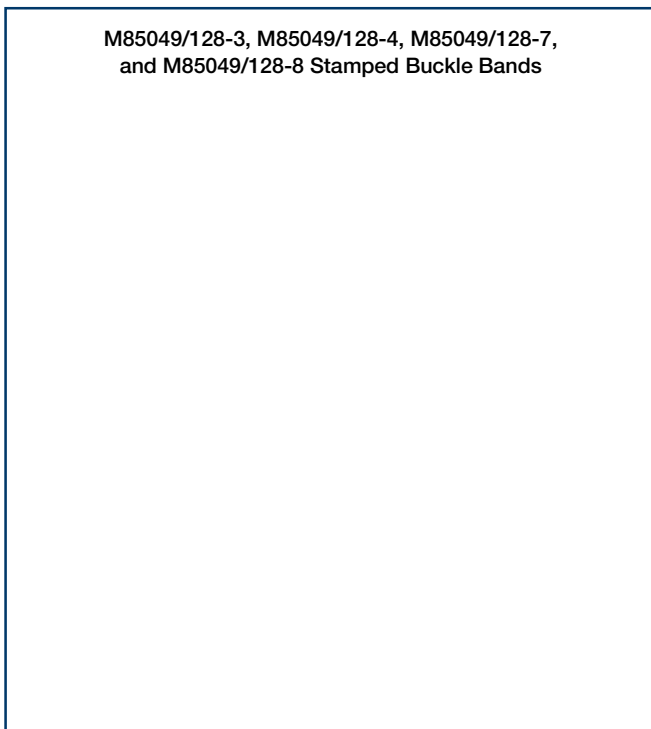
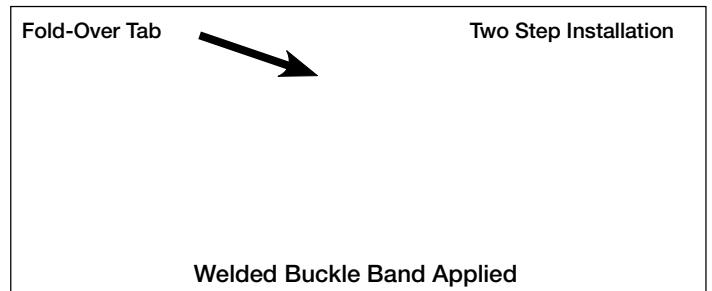
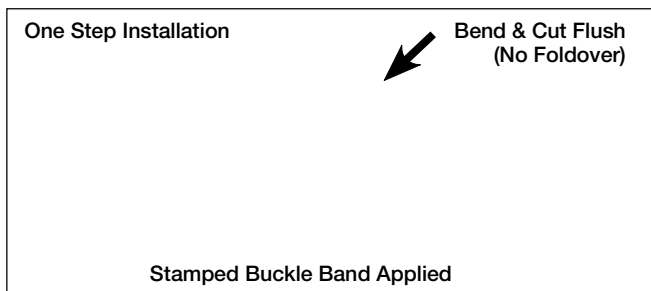

One-Step Banding Tool System

for M85049/128-3, /128-4, /128-7, and /128-8 bands

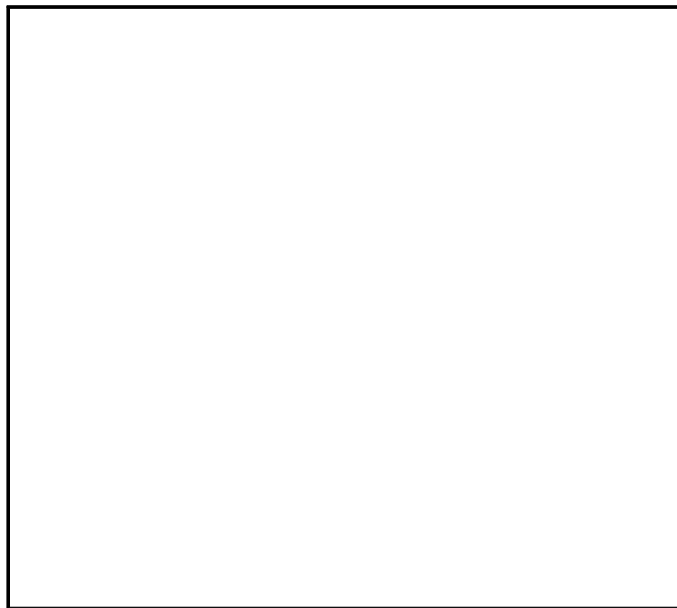

DBS-2100 .250 WIDE BAND APPLICATION TOOL M81306/1A:

- Size and Weight: 6.71" x 6.75" x .92", 1.02 lbs.
- Tension Range: 145–155 lbs.
- Cut-off blades are replaceable with Blade Replacement Kit: DBS-2100-BRK

DBS-2100 & DBS-2200 (M81306/1A & M81306/1B)

(Other Combinations of Tools and Accessories Available - See Page 164-166 for details)

ONE-STEP BAND APPLICATION TOOLS

The One-Step Band Application Tools are built to SAE AS81306/1 specifications and designed to install M85049/128-3, M85049/128-4, M85049/128-7, and M85049/128-8 “stamped buckle” bands. These tools are constructed to survive the demands of production and maintenance use, and remain precisely adjusted to provide a quality band termination.

The tension-lock system gives the operator a positive indication when the precise tension has been applied. The cut-off handle easily cuts, bends, and locks the shield band in one step.

DBS-2200 .125 WIDE MINI-BAND APPLICATION TOOL M81306/1B:

- Size and Weight: 6.71" x 6.75" x .92", 1.02 lbs.
- Tension Range: 75–85 lbs.
- Cut-off blade is replaceable with Blade Replacement Kit: DBS-2200-BRK

VERIFICATION OF ONE-STEP EMI/RFI BAND TOOLS M81306/1C & M81306/1D



DBS-CG7 (M81306/1C) for DBS-2100 tool
(Shown at rest with white line visible)

Field Verification Inspection Gages are available to check the tension of the DMC One-Step Band Tools. These gages have a precise compression mechanism which has a sequence of indicators to verify that the applied tension is within the specified range for the band which is being applied. It is recommended to check the tension periodically, and if it needs adjustment, the instructions and accessories are provided by DMC for that purpose. The .250 width band tool (DBS-2100 Series) requires the DBS-CG7 (M81306/1C) gage, and the .125 width band tool (DBS-2200 Series) requires the DBS-CG8 (M81306/1D) gage.

DMC also offers an Electronic Calibration Instrument for Calibration Laboratory operations. The Part Number DBS-CG4D Electronic Calibration Instrument will allow the operator to gage the exact tension produced by the tool, and therefore, one instrument can be used with either the .250 band width tool, or the .125 band width tool. This instrument is calibrated by DMC, and traceable to NIST.

Part Numbers and ordering information for the Field Verification Inspection Gages and the Electronic Calibration Instrument can be found in the part tables on page 80 under One Step Application Tools, Accessories, and Components.

Use verification equipment in accordance with DMC instructions DBS-CG7-DS, DBS-CG8-DS or DBS-CG4D-DS.

DBS-CG4D (includes fixture with stand and digital readout meter)

Two-Step Banding Tools System

for M85049/128-1, /128-2, /128-5, and /128-6 bands

DBS-1100 (M81306/2-01A)
DBS-1200 (M81306/2-0B)

PBT1100
PMBT1200

DBS-RO3 or DBS-RO5
Roll-Over Tools
(See table on page 163 for details)

USES COMPRESSED AIR TO INSTALL THE SAME
M85049/128-X BANDS AS THE CORRESPONDING HAND TOOL

DBS-1100 AND DBS-1200 HAND OPERATED BANDING TOOLS

TWO STEP BAND APPLICATION TOOLS

DBS-1100 (M81306/2-01A) .250 WIDE BAND TOOL

- Size and Weight: 1.38" x 5.5" x 7.5", 1.4 lbs.
- Tension Range: 140–160 lbs.
- Cut-off blade: replaceable with DBS-1100-7

DBS-1200 (M81306/2-02B) .125 WIDE MINI-BAND TOOL

- Size and Weight: 1.38" x 5.5" x 7.5", 1.4 lbs.
- Tension Range: 70-90 lbs.
- Cut-off blade: replaceable with DBS-1100-7

DBS-RO3 (M81306/2-01C) FOR .250 WIDE BANDS DBS-RO5 (M81306/2-02D) for .125 WIDE BANDS

PBT1100 AND PMBT1200 PNEUMATIC BAND APPLICATION TOOLS

The **PBT1100** & **PMBT1200** series Pneumatic Band Application Tools are lightweight, dependable, and easy to operate. Many of the components are interchangeable with the corresponding hand tool. DMC's Pneumatic Two-Step Banding Tools are compatible with all currently available two-step bands to **M85049/128**.

PBT1100 .250 WIDE BAND APPLICATION TOOL

- Size and Weight: 8.75" L, 1.52 lbs.
- Tension Range: 140–160 lbs.

PMBT1200 .125 WIDE MINI-BAND APPLICATION TOOL

- Size and Weight: 8.75" L, 1.52 lbs.
- Tension Range: 70-90 lbs.

VERIFICATION OF TWO-STEP EMI/RFI BAND

DMC's Two-Step Band Application Tools may be adjusted and verified to insure correct band tension. In order to make this operation simple and efficient for field use, DMC designed and patented a compression fixture system which uses a Go/No-Go Gage to measure the tool tension. Ordering information for the field verification equipment (Part Numbers **DBS-CG2A** and **DBS-CG3A**) can be found in the charts in the following pages.



The **DBS-CG1** Laboratory Calibration Instrument will allow the operator to measure the exact tension produced by the tool.

A free standing holding fixture is available (**DBS-CG1-F**) to aid the calibration process by securing the **DBS-CG1** and banding tool in place. The **DBS-CG1-F** holding fixture secures the banding tool in place during calibration. This fixture only works with the Two-Step Tools and **DBS-CG1** Calibration Instrument (Banding tools and **DBS-CG1-F** are sold separately).



DBS-CG1

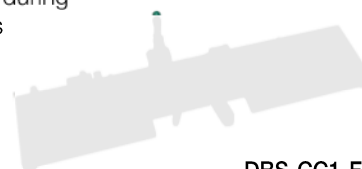

DBS-CG1-F

M85049/128 Band Application System

MIL Part Numbers

MILITARY PART NUMBER TO DMC PART NUMBER CHART

TOOL MIL P/N	DESCRIPTION	WIDTH	DMC P/N	APPLICATION
M81306/1-01	Set: One-Step Tool, Gage, and Tension Key	.250	DBS-2102	M85049/128-3 & -4
M81306/1-02	Set: One-Step Tool, Gage, and Tension Key	.125	DBS-2202	M85049/128-7 & -8
M81306/1A	One-Step Band Installation Tool	.250	DBS-2100	M85049/128-3 & -4
M81306/1B	One-Step Band Installation Tool	.125	DBS-2200	M85049/128-7 & -8
M81306/1C	Tension Verification Compression Fixture	.250	DBS-CG7	DBS-2100
M81306/1D	Tension Verification Compression Fixture	.125	DBS-CG8	DBS-2200
M81306/1E	Tension Adjustment Key	.125 & .250	DBS-2100-32	DBS-2100 & DBS-2200
M81306/2-01	Two-Step Installation Tool and Roll-Over Tool	.250	DBS-1101	M85049/128-1 & -2
M81306/2-02	Two-Step Installation Tool and Roll-Over Tool	.125	DBS-1201	M85049/128-5 & -6
M81306/2-01A	Two-Step Band Tool	.250	DBS-1100	M85049/128-1 & -2
M81306/2-02B	Two-Step Band Tool	.125	DBS-1200	M85049/128-5 & -6
M81306/2-01C	Roll Over Tool	.250	DBS-RO3	M85049/128-1 & -2
M81306/2-02D	Roll Over Tool	.125	DBS-RO5	M85049/128-5 & -6
M81306/2-01E	Tension Verification Gage & Compression Fixture	.250	DBS-CG2A	DBS-1100
M81306/2-02F	Tension Verification Gage & Compression Fixture	.125	DBS-CG3A	DBS-1200

AS85049/128 BAND IDENTIFICATION CHART AND BAND ACCESSORIES

BAND MIL P/N	CONFIGURATION	WIDTH	DMC P/N	TERMINATE WITH
M85049/128-1	Welded Buckle, Flat, .250 wide x 14.25" long	.250	DBS-128-1	Two-Step Only
M85049/128-2	Welded Buckle, Pre-Coiled, .250 wide x 14.25" long	.250	DBS-128-2	Two-Step Only
M85049/128-3	Stamped Buckle, Flat, .250 wide x 14.25" long	.250	DBS-128-3	One-Step Only
M85049/128-4	Stamped Buckle, Pre-Coiled, .250 wide x 14.25" long	.250	DBS-128-4	One-Step Only
M85049/128-5	Welded Buckle, Flat, .125 wide x 9" long	.125	DBS-128-5	Two-Step Only
M85049/128-6	Welded Buckle, Pre-Coiled, .125 wide x 9" long	.125	DBS-128-6	Two-Step Only
M85049/128-7	Stamped Buckle, Flat, .125 wide x 8.52" long	.125	DBS-128-7	One-Step Only
M85049/128-8	Stamped Buckle, Pre-Coiled, .125 wide x 8.52" long	.125	DBS-128-8	One-Step Only

SPLIT RING FOR MID-CABLE SHIELD TERMINATIONS

BAND MIL P/N	CONFIGURATION
(M85049/93-08)*	.500 Dia. Split Ring Set*
(M85049/93-12)*	.750 Dia. Split Ring Set*
(M85049/93-16)*	1.00 Dia. Split Ring Set *
(M85049/93-24)*	1.50 Dia. Split Ring Set*

↑
DIA
↓

*Other sizes and part numbers available.

M85049/128 Band Application System

DMC Part Numbers

ONE-STEP APPLICATION TOOLS, ACCESSORIES AND COMPONENTS

.250 STANDARD WIDTH BAND TOOLS

DMC PART NUMBER	CONFIGURATION
DBS-2100	HAND OPERATED BAND TOOL (M81306/1A)
DBS-2102	HAND OPERATED BAND TOOL SET (INCLUDES DBS-2100, DBS-2100-32 & DBS-CG7) (M81306/1-01)
DBS-2100-32	TENSION ADJUSTMENT KEY (M81306/1E)
DBS-2100-SB	REPLACEMENT STATIONARY BLADE FOR .250 BAND TOOLS (REFERENCE DATASHEET DBS-2100-BRK-DS)
DBS-2100-MB	REPLACEMENT MOVABLE BLADE FOR .250 BAND TOOLS (REFERENCE DATASHEET DBS-2100-BRK-DS)

.125 WIDTH MINI-BAND TOOLS

DMC PART NUMBER	CONFIGURATION
DBS-2200	HAND OPERATED MINI-BAND TOOL (M81306/1B)
DBS-2202	HAND OPERATED MINI-BAND TOOL SET (INCLUDES DBS-2200, DBS-2100-32, DBS-CG8) (M81306/1-02)
DBS-2100-32	TENSION ADJUSTMENT KEY (M81306/1E)
DBS-2200-SB	REPLACEMENT STATIONARY BLADE FOR .125 BAND TOOLS (REFERENCE DATASHEET DBS-2200-BRK-DS)
DBS-2200-MB	REPLACEMENT MOVABLE BLADE FOR .125 BAND TOOLS (NOTE: NOT FIELD REPLACEABLE, CONTACT DMC)

TOOL VERIFICATION INSTRUMENTATION

DMC PART NUMBER	CONFIGURATION
DBS-CG4D	LABORATORY VERIFICATION INSTRUMENT (ELECTRONIC) FOR DBS-2100 & DBS-2200 SERIES BAND TOOLS
DBS-CG7	FIELD VERIFICATION INSPECTION GAGE FOR DBS-2100, M81306/1C

Typical Shield Band/Backshell Applications

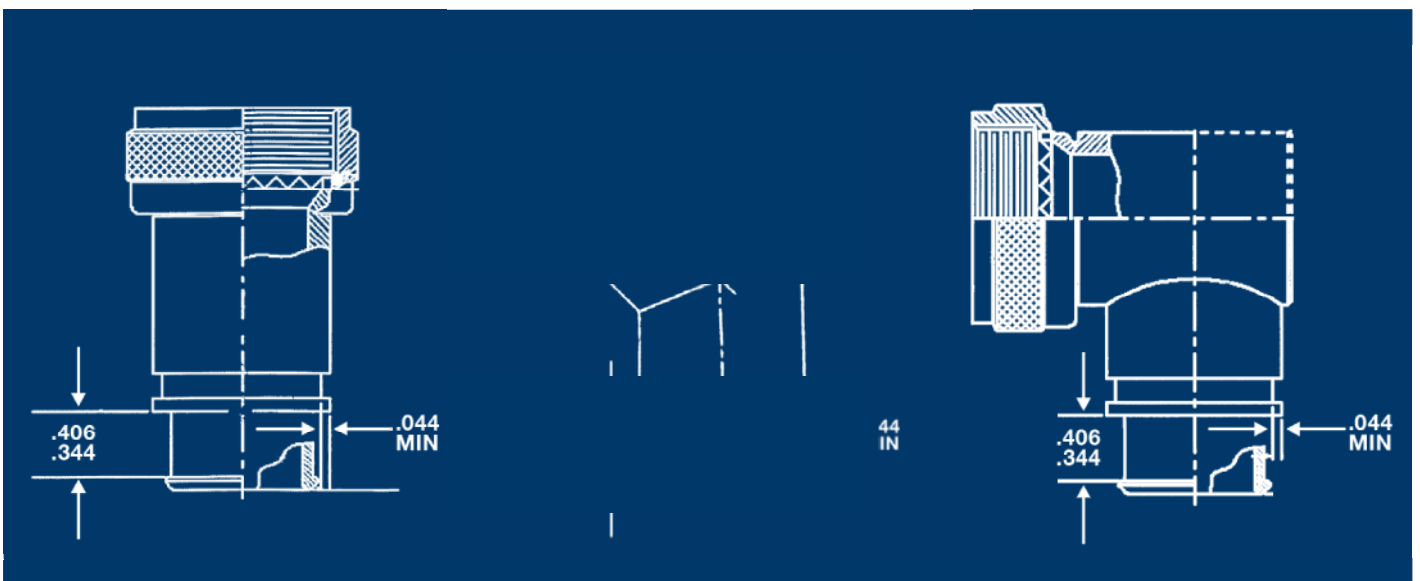

M85049/128 Band Application System

DMC Part Numbers

TWO-STEP APPLICATION TOOLS, ACCESSORIES AND COMPONENTS

.250 Standard Width Band Tools	
DMC PART NUMBER	CONFIGURATION
DBS-1100	Hand Operated Band Tool (M81306/2-01A)
DBS-1101	Hand Operated Band Application Tool Set M81306/2-01 (includes DBS-1100, DBS-R03)
DBS-1102	Hand Operated Band Application Tool Set includes DBS-1100, DBS-R03, DBS-CG2 & G691)
DBS-1100-32	Tension Adjustment Key
DBS-1100-7	Replacement Blade for .250 Band Tools
DBS-R03	Roll-Over Tool for .250 Band Tab, M81306/2-01C
.125 Width Mini-Band Tools	
DMC PART NUMBER	CONFIGURATION
DBS-1200	Hand Operated Mini-Band Tool M81306/2-02B
DBS-1201	Hand Operated Mini-Band Application Tool Set M81306/2-02 (Includes DBS-1200, DBS-R05)
DBS-1202	Hand Operated Mini-Band Application Tool Set (Includes DBS-1200, DBS-R05, DBS-CG3 & G752)
DBS-1100-7	Replacement Blade for .125 Band Tools
DBS-R05	Roll-Over Tool for .125 Band Tab (M81036/2-02D)
Pneumatic Band Tools for .250 width Bands (Welded Buckle Bands Only)	
DMC PART NUMBER	CONFIGURATION
PBT1100	Two-Step Pneumatic Band Application Tool
Pneumatic Band Tools for .125 width Bands (Welded Buckle Bands Only)	
DMC PART NUMBER	CONFIGURATION
PMBT1200	Two-Step Pneumatic Band Application Tool
Tool Verification Instrumentation	
DMC PART NUMBER	CONFIGURATION
DBS-CG1	Laboratory Verification Instrument for DBS-1100 & DBS-1200 series band tools
DBS-CG1-F	DBS-CG1 Holding Fixture (Banding tool & DBS-CG1 optional)
DBS-CG2	Field Verification Fixture for DBS-1100
G691	Go/No-Go Gage for DBS-CG2 Fixture
DBS-CG2A	M81306/2-01E Verification Set which includes DBS-CG2 & G691
DBS-CG3	Field Verification Fixture for DBS-1200
G752	Go/No-Go Gage for DBS-CG3 Fixture
DBS-CG3A	M81306/2-02F Verification Set which includes DBS-CG3 & G752
Banding Application Kit	
DMC PART NUMBER	CONFIGURATION
DMC60A	.250 Banding Tool Kit with bands and shielding components*
DMC1379	.250 Banding Tool Kit without cutters and shielding components*

*Consult DMC for tool kit contents and other kit options.

Tensile Test Systems

For Wire Terminations & Similar Applications



MPT-250C

PT-40XP

PT-150HA

HPT-200B

Tensile Testing Equipment

WIRE CRIMP PULL TESTING

Pull Testing is the most meaningful test in the wire termination industry. Pull Testing to the minimum tensile value, or to the breaking strength of a terminated wire sample will resolve all concerns about the mechanical properties of the crimped or welded termination, and it will indicate, with reliable accuracy, the electrical integrity of a connection.

Military/Aerospace Specifications are mostly based on the test procedure that is called out in EIA TP-08B Crimp Tensile Strength Test Procedure for Electrical Connectors.

Tensile strength testing in accordance with this document requires a motorized pull tester that is capable of moving at a rate of 1 inch (plus or minus 1/4 inch) per minute, and gripping jaws that hold each end of the sample, without distorting the crimp area.

The following specifications are generally referenced for minimum test values: Contacts AS39029, Terminals AS7928, Crimp Tools MIL-DTL-22520, and Space Applications NASA-STD-8739.4.

NOTE: The aircraft/aerospace tensile test values are somewhat higher due to the high performance design of the tools, contacts/terminals, conductors, and insulation.

Choosing the Pull Tester that meets your needs is a very important

issue for aerospace applications. A motorized tester is recommended over a manual tester for test lab, QA compliance, and specification/process/contract obligations. This is due to the controlled speed (rate of pull is generally required to be 1 inch per minute, plus or minus 1/4 inch). Manual testers do not comply with the head speed requirement, and can produce inconsistent readings if they are "jerked" by the operator.

Pull Testers that are to be used for in-house verification, tool calibration/set-up, and not for compliance with QA or specification/process/contract obligations may be motorized or manual. There are economical manual pull testers that are available, and they will serve as good in-house support equipment for the manufacturing/set-up operations. When operating these testers, the operator should always move the handle slowly for the most consistent readings.

THE DEPENDABLE ALPHATRON™ TENSILE TEST SYSTEM FROM DMC



The Alphatron™ Tensile Test System from DMC is a line of Electronic Tensile Test Systems which may be used in conjunction with SPC Programs or other Quality Control disciplines in both OEM and maintenance applications. The electronic digital readout displays are a fast and reliable source of test data.

The rugged construction and the portable design of these test machines make any of them a superior choice for on-site or laboratory use in an infinite variety of applications. The operation of the equipment is simple yet versatile, and DMC will customize the gripping jaws or other components to make test sample installation and removal an easy task.

Models are available with output display readings in Pounds, Newtons, and/or Kilograms to conform with the requirements of the user's system. Units are available for either 115 or 230 volt power input.

It's only natural that the company which supplies the best wire termination tools and equipment would add the very best Digital Tensile Testers to further meet the demand for fewer sources and improved support through a wider range of user needs.

Tensile Test Systems

For Wire Terminations & Similar Applications



THE DEPENDABLE ALPHATRON™ TENSILE TEST SYSTEM

The Alphasron™ Tensile Test System from DMC is a line of Electronic Tensile Test Systems which may be used in conjunction with SPC Programs or other Quality Control disciplines in both OEM and maintenance applications. The

electronic digital readout displays are a fast and reliable source of test data.

The rugged construction and the portable design of these test machines make any of them a superior choice for on-site or laboratory use in an infinite variety of applications. The operation of the equipment is simple yet versatile, and DMC will customize the gripping jaws or other components to make test sample installation and removal an easy task.

Models are available with output display readings in Pounds, Newtons, and/or Kilograms to conform with the requirements of the user's system. Units are available for either 115 or 230 volt power input.

It's only natural that the company which supplies the best wire termination tools and equipment would add the very best Digital Tensile Testers to further meet the demand for fewer sources and improved support through a wider range of user needs.

The **MPT-250C** Motorized Wire Crimp Pull Tester is ideal when a constant rate of pull is desired. It tests crimp strength on terminations up to size 8

in Mil-Spec applications, and size 1/0 AWG in commercial and automotive applications.

The **PT-150HA** Manual Wire Crimp Pull Tester is ideal for testing crimp strength up to size 10 for Mil-Spec applications, and size 4 AWG for commercial and automotive applications.

The **HPT-200B** hand-held pull tester blends the accuracy and rugged design of the Alphasron™ pull testers into a self-contained, portable, rechargeable battery powered unit. It is ideal for testing crimp strength up to size 10 AWG in Mil-Spec applications, and size 10 AWG in commercial and automotive applications.

The **PT-40XP** Electronic Manual Tensile Test System is specially designed to test the lower range tensile values from 0.1 to 40 lbs.

MOTORIZED PULL TESTER
MODEL MPT-250C

MANUAL PULL TESTER
MODEL PT-150HA

HAND-HELD PORTABLE
PULL TESTER MODEL HPT-200B

SMALL GAGE WIRE CRIMP
PULL TESTER MODEL PT-40XP

GENERAL SPECIFICATIONS

	MPT-250C	PT-150HA	HPT-200B	PT-40XP
Capacity	250 lbf 113 kg 1112 N	150 lbf 68.0 kg 667 N	200 lbf 90.7 kg 889 N	40 lbf 18.1 kg 170 N
Accuracy	±0.5% (1/2 of 1%)	±0.5% (1/2 of 1%)	±0.5% (1/2 of 1%)	±0.5% (1/2 of 1%)
Resolution	0.1 lbf	0.1 lbf	0.1 lbf	0.1 lbf
Display Type	Digital Display w/Peak Hold Reading	Digital Display w/Peak Hold Reading	Digital Display w/Peak Hold Reading	Digital Display w/Peak Hold Reading
Display	LED w/.56" high digits	LED w/.56" high digits	LED w/.15" high digits	LED w/.56" high digits
Electrical	115 VAC 50/60 Hz 230 VAC 50/60 Hz	115 VAC 50/60 Hz 230 VAC 50/60 Hz	115 VAC 50/60 Hz 230 VAC Int. Battery	115 VAC 50/60 Hz 230 VAC Int. Battery
Operating Temperature	50°F to 100°F (10° to 38°C)	50°F to 100°F (10° to 38°C)	40°F to 100°F (5° to 38°C)	50°F to 100°F (10° to 38°C)

DIMENSIONS

	MPT-250C	PT-150HA	HPT-200B	PT-40XP
Height	9.5 in. (24.13 cm)	5 in. (12.7 cm)	5.88 in. (14.94 cm) case	5.9 in. (14.97 cm) case
Width	10 in. (25.4 cm)	8.5 in. (21.59 cm)	2.53 in. (6.43 cm) case	11.75 in. (29.81 cm) case
Depth	15 in. (38.1 cm)	16 in. (40.64 cm)	1.32 in. (3.36 cm) case	5.8 in. (14.73 cm) case
Weight	26 lbs. (11.78 kg) (less options)	15.2 lbs. (6.89 kg) (less options)	0.7 lbs. (0.3 kg) case and hand unit	5.7 lbs. (2.59 kg) case (less options)

MPT-250C

Motorized Wire Crimp Pull Tester

The **MPT-250C** is a Motorized Tensile Wire Crimp Pull Tester used to test a crimp contact's or terminal's tensile strength. The unit has a range of 2.5 lbf to 250 lbf and a full color LCD touchscreen interface. Includes data capture capability for exporting test data to a PC via USB or RS-232. The **MPT-250C** meets UL, ISO, SAE, MIL, and ASTM tensile test requirements.

The **MPT-250C** Motorized Wire Crimp Pull Tester is ideal when a constant rate of pull is desired. It tests crimp strength on terminations up to size 8 in Mil-Spec applications, and size 1/0 AWG in commercial and automotive applications.

FEATURES AND SPECIFICATIONS

- 2 Test Types: "Pull to Fail" and "Force Hold"
- Data Capture (measures continuous and peak force values)
- Intuitive Full Color Touchscreen LCD User Interface
- Easy Setup, Operation, and Grip Change
- Force Measurement Range: 2.5 – 250.0 lbf (113kgf or 1112.0N)
- Force Measurement Accuracy: +/- 0.5% Full Scale
- Force Readout in (lbf, kgf, N)
- Pull Rate Speeds: 1 to 10 inches per minute (inch/min)
- Accommodates Most 10 AWG - 26 AWG Wire
- Communication Ports: Serial RS-232, USB 2.0
- Pull Rate Accuracy: 1-5 +/- 0.125 inch/min, 6-10 +/- 0.250 inch/min

OPTIONAL ACCESSORIES

- Slotted Terminal Grip (P/N 15-3087C)
- Post Ring Terminal Grip (P/N 15-0066C)
- Mini-Vise Miniature Contact Grip (P/N 15-3314)
- Safe-T-Cable® Grip Set (P/N 15-3318)
- Customized Grips are available

PHYSICAL

- Weight 23.64 lbs (less options)
- Shipping Weight ≈ 40.6 lbs (with standard grips)
- Case Weight 16.12 lbs
- Base Dimensions: 13.3" Wide x 6" High x 11" Deep

Terminal & Wire Grips

Custom Grips Available. Consult DMC for details.

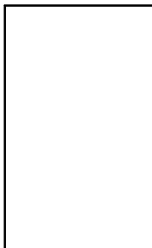

P/N 15-3202C
SELF-TIGHTENING
GRIP (STANDARD)

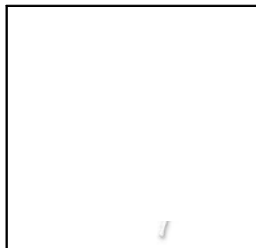

P/N 15-3046
WIRE PULL GRIP
(STANDARD)

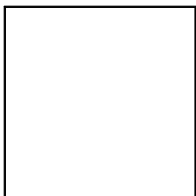

P/N 15-3087C
SLOTTED TERMINAL
GRIP (OPTIONAL)

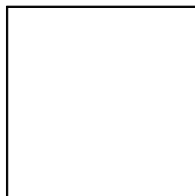

P/N 15-0066C
POST TERMINAL GRIP
(OPTIONAL)

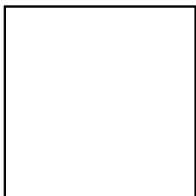

P/N 15-3314
MINI-VISE GRIP
(OPTIONAL)

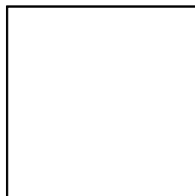

P/N 15-3318
SAFE-T-CABLE® PULL
AND GRIP SET
(OPTIONAL)

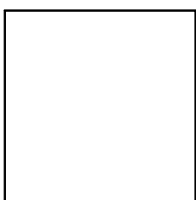

P/N MPT-VF
WEIGHT HANGER FOR
VERIFICATION (OPTIONAL)

MPT-250C



MINIMUM TENSILE STRENGTH REQUIREMENT*				
CONDUCTOR SIZE AWG (REFERENCE)	UL 486A TEST VALUES (COMMERCIAL STANDARD)		TYPICAL MIL-SPEC (AS22520, AS7928, ETC)	
	AWG	Pounds	Newtons	Pounds
26	3	13.4	7	31.2
24	5	22.3	10	44.5
22	8	35.6	15	66.8
20	13	57.9	19	84.6
18	20	89.0	38	169.1
16	30	133.5	50	222.5
14	50	222.5	70	311.5
12	70	311.5	110	489.5
10	80	356.0	150	667.5

*Consult DMC for specific information on tensile strength standards.

PT-150HA

Wire Crimp Pull Tester

The **PT-150HA** Manual Wire Crimp Pull Tester is ideal for testing crimp strength up to size 10 for Mil-Spec applications*, and size 4 AWG for commercial and automotive applications**. The **PT-150HA** may be used in conjunction with SPC Programs or other Quality Control disciplines in both OEM and maintenance applications. The electronic digital readout display is a fast and reliable source of test data.

The operation of the equipment is simple yet versatile, and DMC will customize the gripping jaws or other components to make test sample installation and removal an easy task.

* Size 10 MIL Spec wire pull test is typically 150 pounds force. Sample may not break at 150 pounds.

** May require special grips due to wire diameter.

STANDARD FEATURES

- Capacity: 150 lb, 667 N, 68 Kg
- Display units factory set for pounds, newtons or kilograms
- Resolution: 0.1 lb
- Accuracy: $\pm 0.5\%$ of full scale
- Digital Display with Peak Hold
- Backlit LCD Display with 0.56" High Digits
- Self-Tightening Wire Grip
- 15 Position Slotted Terminal Contact Grip
- Lever Arm Pull Mechanism
- Input power: 100-240 VAC 50/60 Hz

OPTIONAL ACCESSORY GRIPS

- Ring Terminal Grip (P/N 15-0066)
- Self-Tightening Grip (P/N 15-3202)
- Right Angle Terminal Grip (P/N 15-3042)

PHYSICAL

- Weight 15.2 Lbs.
- (Shipping Weight 21 Lbs.)
- Stand Dimensions:
H. 5", W. 8.5", D. 16"

CALIBRATION

- New units supplied with certificate of calibration traceable to NIST
- Factory calibration available

OPTIONAL FEATURES

- Custom grips available

PT-150HA



Terminal & Wire Grips

Custom Grips Available. Consult DMC for details.

SLOTTED TERMINAL GRIP (standard)



P/N 15-3087

RING TERMINAL GRIP (optional)



P/N 15-0066

SELF-TIGHTENING GRIP (optional)

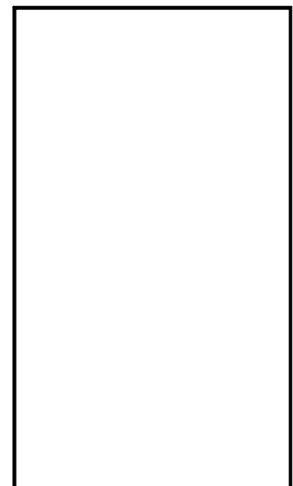

P/N 15-3202

See disclaimer of liability on page 27.

HPT-200B Handheld Portable Pull Tester

HPT-200B

The **HPT-200B** hand held pull tester combines the accuracy and rugged design of the Alphasatron™ pull testers into a portable battery powered unit. We follow that up with our expert factory service and calibration.

The lightweight Alphasatron™ **HPT-200B** is a self-contained tester that extends your testing capability to the shop floor. You no longer have to wait for process samples to arrive in the QA Lab. Durable construction and a convenient carry case ensure protection. The Low Stress tensioning mechanism makes the **HPT-200B** versatile and easy to use.

STANDARD FEATURES

- Portable, lightweight and ergonomic design
- Built-in NiMH battery, with charger/AC power
- Up to 24 hours use on a single charge
- Low stress tensioning mechanism
- Protective carrying case
- Built-in calibration procedure
- Accuracy: (0.5% of full scale)
- Resolution: (0.1 pounds)
- Display in lbf, ozF, kgF, gF, or N
- Measure Lite data capture software

SPECIFICATIONS

- Capacity: 200 LBF, 90.7 kg, 889N
- Accuracy: $\pm .5\%$ of full scale
- Resolution: .1 lbf
- Display Type: Digital display w/peak hold reading
- Display: LCD w/.15 in. high digits
- Electrical: 100-240VAC charging adapter
- AC or 8.4 V NiMH rechargeable battery
- Operating Temperature: 40°F to 100°F (10° to 38°C)
- Height: 5.88 in. (14.94 cm) case
- Width: 2.53 in. (6.43 cm) case
- Depth: 1.32 in. (3.36 cm) case
- Weight: .7 lbs. (1.21 kg) case and hand unit



PT-40XP Low Range Precision Pull Tester

PT-40XP

The **PT-40XP** Electronic Manual Tensile Test System is specially designed to test the lower range tensile values from 0.1 to 40 lbs. The **PT-40XP** may be used in conjunction with SPC Programs or other Quality Control disciplines in both OEM and maintenance applications. The electronic digital readout display is a fast and reliable source of test data. This unit easily accommodates short wire leads (.75" minimum length test sample).

STANDARD FEATURES

- Capacity: 40 lb, 170 N/18.2 KGS
- Display units factory set for pounds, kilograms or newtons
- Resolution: 0.1 lb / 0.1 N
- Accuracy: $\pm 0.5\%$ of full scale
- Digital Display with Peak Hold
- LCD Display with 0.56" High Digits
- Two Self-Tightening Wedge-Grips and One Cam-Grip Assembly
- Precise Screw Pull Mechanism

POWER SPECS

- Built-in NiMH Battery, with Charger
- 14 Hours of Use on a Single Charge
- 100-240 VA Power Adapter with
- 3 interchangeable plug adapters included





PHYSICAL

- Weight 5.7 lbs.
- Dimensions: Height: 5.9", Width: 11.75", Depth 5.8"

CALIBRATION

- Verify Calibration Anytime
- Factory calibration available
- New units supplied with certificate of calibration traceable to NIST
- In order to maintain NIST traceability, Do Not Exceed 12 Months Between Factory Calibrations





Terminal and Wire Grips

MPT-250C	PART NUMBER	ILLUSTRATION	CAPACITY	TYPE	APPLICATION
	15-3087C		250 lbf	General Purpose Lower Grip	Terminal Lugs Machined Contacts
	15-0066C		250 lbf	Ring Lower Grip	Ring Terminal Lugs
	15-3202C		250 lbf	Self Tightening Lower Grip	All Wire Terminations
	15-3314		250 lbf	Mini-Vise Grip	Miniature Contacts
	15-3242C		100 lbf	Low Tensile Miniature Contact, Lower Grip	Ring Terminals
	15-3046		250 lbf	T-Handle Large Insulation Upper Grip	High Force Wire Grip
	15-3318		250 lbf	Safe-T-Cable® Pull and Grip Set	Safe-T-Cable® Testing

Tensile Testing Equipment

HPT-200B	PART NUMBER	ILLUSTRATION	CAPACITY	TYPE	APPLICATION
	15-3035		200 lbf	Standard Slotted Disc Upper Grip	Terminals
	TST-250-12		200 lbf	Clamp Grip	Terminals

Terminal and Wire Grips

PT-150HA	PART NUMBER	ILLUSTRATION	CAPACITY	TYPE	APPLICATION
	15-3087		250 lbf	General Purpose Lower Grip	Terminal Lugs Machined Contacts
	15-0066		250 lbf	Ring Lower Grip	Ring Terminal Lugs
	15-3202		250 lbf	Self Tightening Lower Grip	All Wire Terminations
	15-3242		250 lbf	Locking Ring Terminal Lower Grip	Ring Terminals

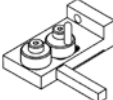
PT-40XP	PART NUMBER	ILLUSTRATION	CAPACITY	TYPE	APPLICATION
	GF-11		40 lbf	Standard Contact Grip	Miniature Contacts
	PT-40XP-GA1		40 lbf	Standard Wire Grip	Wire Grip

Wire Standards Pull Test Values

CONDUCTOR SIZE AWG (REFERENCE)	UL 486A CAPACITY (COMMERCIAL STANDARD)		TYPICAL MIL-SPEC* (AS22520, AS7928, ETC)	
	Pounds	Newtons	Pounds	Newtons
30	1-1.5	6.7	N/A	N/A
28	2	8.9	N/A	N/A
26	3	13.4	7	31.2
24	5	22.3	10	44.5
22	8	35.6	15	66.8
20	13	57.9	19	84.6
18	20	89.0	38	169.1
16	30	133.5	50	222.5
14	50	222.5	70	311.5
12	70	311.5	110	489.5
10	80	356.0	150	667.5
8	90	400.5	225	1001.3
6	100	445.0	300	1335.0
4	140	623.0	400	1780.0
3	160	712.0	N/A	N/A
2	180	801.0	550	2447.5
1	200	890.0	650	2892.5
1/0	250	1112.5	700	3115.0
2/0	300	1235.0	750	337.5
3/0	350	1557.5	825	3671.3
4/0	450	2202.5	875	3893.8
250 MCM	500	2225.0	N/A	N/A
300 MCM	550	2447.5	N/A	N/A
350 MCM	650	2670.5	N/A	N/A
400 MCM	650	2892.5	N/A	N/A
500 MCM	800	3560.0	N/A	N/A
600 MCM	900	4005.0	N/A	N/A
700-2000	1000	4450.0	N/A	N/A

*This table lists general crimp termination tensile values. For specific information, consult DMC.

DMC does not provide connectors, contacts or wiring components. Parts shown here are for reference only. See disclaimer of liability on page 18.

ST825 Swaging Tool for Cable (Wire Rope)

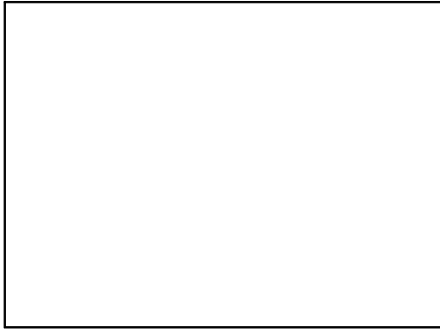

All swaging and cutting dies are of a hardened steel and are polished and heat treated to withstand high impact. Each die is marked to indicate the type and size terminal to be swaged, or cable to be cut.

This rugged tool, minus the dies, weighs less than 20 lbs. It operates on standard shop air pressure of 80 to 120 PSI and is designed for hand operation or it can be mounted on a cushion base plate for bench top use.

The DMC **ST825** Swaging Tool is used to swage terminals to flexible aircraft cable (usually stainless steel) and is built to meet government specifications. The complete tool consists of a cylinder and yoke assembly that is easily accessible for quick changing of dies, air hose assembly with a shut off valve and a single action foot control valve assembly with lubricator and air filter.

TYPICAL SWAGING APPLICATIONS

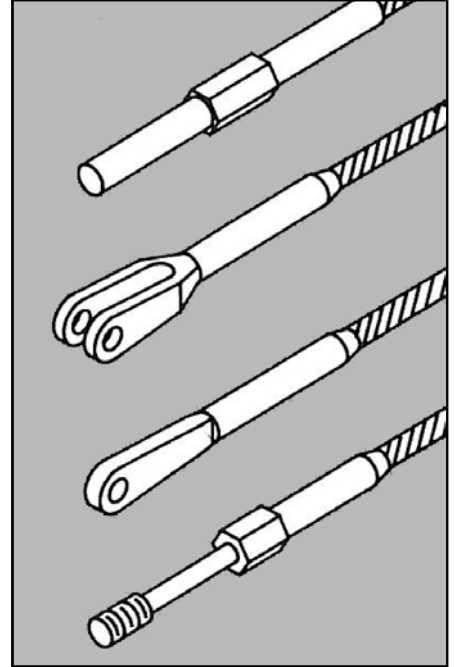

ST825 Swaging Tool for Cable (Wire Rope)



ST825 WITH SWAGING DIES



ST825 WITH CUTTING DIES



DMC99 TOOL KIT

This tool is also offered in the form of a tool kit (P/N **DMC99**). This includes additional items such as a base plate, gages, the complete range of cutting and swaging dies, an instruction manual, all packaged in a durable metal carrying case. This tool kit meets federal specification GGG-S-00825A (GSA-FSS) NSN 5130-00-712-4855.

TO BE USED ON MIL-W-83420, MIL-W-87161 AND SPECIFIED WIRES.

DMC PART NO.	QTY.	TERMINAL REF. (MIL.#)	DESCRIPTION	CABLE DIA.	CROSS REF. ATI P/N
G689	1		GAGE SET		AT5205G
ST825003	1		SPACER		AT520SP-1
ST825SDB-2	2	MS20663-2	SWAGING DIE	1/6"	AT520CDB-2
ST825SDB-3	2	MS20663-3	SWAGING DIE	3/32"	AT520CDB-3
ST825SDB-4	2	MS20663-4	SWAGING DIE	1/8"	AT520CDB-4
ST825SDB-5	2	MS20663-5	SWAGING DIE	5/32"	AT520CDB-5
ST825SDB-6	2	MS20663-6	SWAGING DIE	3/16"	AT520CDB-6
ST825SSB-2-L	1	MS20664-2 (L)	SWAGING DIE , LEFT	1/16"	
ST825SSB-2-R	1	MS20664-2 (R)	SWAGING DIE , RIGHT	1/16"	*AT520CSB-2
ST825SSB-3-L	1	MS20664-3 (L)	SWAGING DIE , LEFT	3/32"	
ST825SSB-3-R	1	MS20664-3 (R)	SWAGING DIE, RIGHT	3/32"	*AT520CSB-3
ST825SSB-4-L	1	MS20664-4 (L)	SWAGING DIE, LEFT	1/8"	
ST825SSB-4-R	1	MS20664-4 (R)	SWAGING DIE, RIGHT	1/8"	* AT520CSB-4
ST825SSB-5-L	1	MS20664-5 (L)	SWAGING DIE , LEFT	5/32"	
ST825SSB-5-R	1	MS20664-5 (R)	SWAGING DIE, RIGHT	5/32"	*AT520CSB-5
ST825SSB-6-L	1	MS20664-6 (L)	SWAGING DIE, LEFT	3/16"	
ST825SSB-6-R	1	MS20664-6 (R)	SWAGING DIE , RIGHT	3/16"	*AT520CSB-6
ST825SB-2	2	BA3-2	SWAGING DIE	1/16"	AT520CB-2
ST825SB-3	2	BA3-3	SWAGING DIE	3/32"	AT520CB-3
ST825SB-4	2	BA3-4	SWAGING DIE	3/32"	AT520CB-4
ST825SL-2	2	**2	SWAGING DIE	1/16"	AT520CS-2
ST825SL-3	2	**3	SWAGING DIE	3/32"	AT520CS-3
ST825SL-4	2	**4	SWAGING DIE	1/8"	AT520CS-4
ST825SL-5	2	**5	SWAGING DIE	5/32"	AT520CS-5
ST825SL-6	2	**6	SWAGING DIE	3/16"	AT520CS-6
ST825SL-7	2	**7 (NOTE)	SWAGING DIE	7/32"	AT520CS-7
ST825SL-8	2	**8	SWAGING DIE	1/4"	AT520CS-8
ST825CD-2-1	1		CUTTING DIE	1/16"	AT520CD-2
ST825CD-2-2	1		CUTTING PUNCH	1/16"	AT520CP-2
ST825CD-3-1	1		CUTTING DIE	3/32"	AT520CD-3
ST825CD-3-2	1		CUTTING PUNCH	3/32"	AT520CP-3
ST825CD-4-1	1		CUTTING DIE	1/8"	AT520CD-4
ST825CD-4-2	1		CUTTING PUNCH	1/8"	AT520CP-4
ST825CD-5-1	1		CUTTING DIE	5/32"	AT520CD -5
ST825CD-5-2	1		CUTTING PUNCH	5/32"	AT520CP-5
ST825CD-6-1	1		CUTTING DIE	3/16"	AT520CD-6
ST825CD-6-2	1		CUTTING PUNCH	3/16"	AT520CP-6
ST825CD-7-1	1		CUTTING DIE	7/32"	AT520CD-7
ST825CD-7-2	1		CUTTING PUNCH	7/32"	AT520CP-7
ST825CD-8-1	1		CUTTING DIE	1/4"	AT520CD-8
ST825CD-8-2	1		CUTTING PUNCH	1/4"	AT520CP-8

*Sets only

**MS20658, MS20667, MS2160, MS21259

(NOTE) Uses the ST825SL-6 die set for MS20658-7 terminal.

DMC Maintenance Kit Solutions

DMC has built Wiring System Maintenance Kits for over 60 years and has tool kits already designed for most Military and Commercial Aircraft & Ground Vehicles. This includes Helicopters, Shipboard Systems, Weapons Systems, and other High-Demand Electrical Systems.

THE PROBLEM

Complex Wiring Systems: Today's sophisticated aircraft and weaponry electronics have become increasingly complex, and the electrical system operation is critical.

Personnel Training: The technicians who must maintain these systems may not have current knowledge about all types of terminations and tooling needed to repair the vast number of interconnections which make up these systems.

TIME CONSTRAINTS/AOG (Aircraft on Ground)

Time Requirements: Once the aircraft becomes inoperable because of a connector failure, it is necessary to replace the connector, contact, terminal, or other wiring device as quickly as possible to avoid revenue loss due to AOG. DMC kits supply your staff with both the information and the tools necessary to make this type of repair in the **shortest time possible.**

THE SOLUTION

Research: DMC's knowledgeable staff does the necessary research to relieve this pressure, and eliminate the guesswork or haphazard (trial-and-error) utilization of tools and wiring devices by the development of detailed Tool Selection Charts which cross reference all of the connectors with complete repair tool data.

Packaging: DMC then packages these Tool Selection Charts, Contents Charts, and Instruction Sheets with all the crimping tools, turret heads, dies, wire strippers, installing tools, removal tools and other accessories necessary to support the electrical wiring system in durable cases or rugged cabinets so the tools are properly organized and protected. Each tool has a well-designed cavity which extends the life and capability of the tool.

Ready Access: The technician now has ready access to the technical data and tools for reliable, cost-effective Total Wiring System Support.

CUSTOM KITS

Building a tool kit to service an entire wiring system involves extensive research to select correct tooling and ensure all serviceable connectors, terminals, splices and contacts are covered. Technicians who are responsible for the maintenance or production of entire systems cannot be expected to know all the answers, nor do they have the time to do the necessary research or locate tooling.

DMC can work with you to select or custom design the right Wiring System Maintenance Kit to meet your individual requirements. After you have purchased a DMC Maintenance Kit, our trained personnel are available with the information and tools you need to keep your kit up-to-date.

Custom Maintenance Kits

60 YEARS OF INDUSTRY KNOWLEDGE

DMC has the knowledge and does the technical research for your application. We apply our decades of connector industry experience and wealth of tooling information into developing the technical data for every Wiring System Maintenance Kit we build. We design and manufacture a tool kit package which includes: All the necessary tooling (crimping tools, dies, heads, installing tools, removal tools, gages, wire strippers for circular and R.F. connectors and more), valuable tool application data which eliminates guesswork, and complete instructions on set up and use of each tool and accessory.

ENVIRONMENTAL PACKAGING

An analysis of the environmental conditions and other factors is of absolute necessity from the beginning. On-site field maintenance requires a packaging system where maximum portability and component protection are the controlling factors, whereas maintenance kits designed for depot-level support are based primarily on convenient location of components and other significant factors important to that environment.

CUSTOM SIZES

Depending upon the complexity of the system being supported, the tools and technical data are protected in various formats: from a single metal tool box for basic, on-site repairs to multi-drawer, roll-around cabinets for depot-level repairs.

FOAM INSERTS

Foam inserts (standard for all DMC kits) provide each component with a designated storage space which is indicated on the Contents Charts. This assures the technician that no needed components are missing prior to departing to make the repair. The technician also knows, prior to leaving the on-site repair, that if a foam compartment is empty, then a component is missing and must be retrieved. This helps eliminate FOD (Foreign Object Damage) problems.

ALL IN ONE

Since all of these tools, together with their operating instructions, are contained in a single kit, the connector repair can be made in the shortest time possible, thus permitting a rapid return of your aircraft to service.

Optional color contrast foam



DMC kits are available in multiple case materials including: fiberglass, steel, and copolymer polypropylene. Kits are available in multiple sizes, colors, and configurations. Roll-around kits are also available in multiple sizes.

Technical Data Package

DMC Maintenance Kits

INSTRUCTIONS AND TOOL SELECTION CHARTS

DMC1264

ELECTRICAL CONNECTOR MAINTENANCE/REPAIR KIT
FOR

BOEING 737-800
737-800, 737-700 AND 737-900

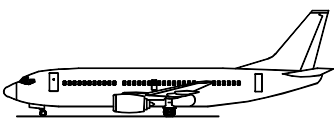

PERIODIC CALIBRATION & REFURBISHMENT SERVICE AND REPLACEMENT
OF LOST/DAMAGED TOOLS ARE AVAILABLE

CONTACT:

DMC DANIELS MANUFACTURING CORPORATION

526 THORPE ROAD ORLANDO, FLORIDA 32824 USA
TELEPHONE: (407) 855-6161 FAX: (407) 855-6884
www.dmctools.com dmc@dmctools.com

REV. 8

Technical Data Package

CONTENTS CHART
COMPARTMENT A

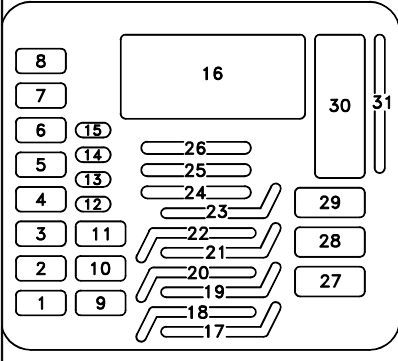

ITEM	DESCRIPTION
A1.	WS-45 (DANIELS) JACKET TRIM JIG
A2.	WS-46 (DANIELS) JACKET TRIM JIG
A3.	WS-47 (DANIELS) JACKET TRIM JIG
A4.	WS-48 (DANIELS) JACKET TRIM JIG
A5.	WS-49 (DANIELS) JACKET TRIM JIG
A6.	WS-50 (DANIELS) JACKET TRIM JIG
A7.	WS-51 (DANIELS) JACKET TRIM JIG
A8.	WS-52 (DANIELS) JACKET TRIM JIG
A9.	WS-53 (DANIELS) JACKET TRIM JIG
A10.	WS-54 (DANIELS) JACKET TRIM JIG
A11.	WS-55 (DANIELS) JACKET TRIM JIG
A12.	WS-56 (DANIELS) DIELECTRIC TRIM JIG
A13.	WS-57 (DANIELS) DIELECTRIC TRIM JIG
A14.	WS-58 (DANIELS) DIELECTRIC TRIM JIG
A15.	WS-59 (DANIELS) DIELECTRIC TRIM JIG
A16.	TW-1 (110) (TELETYPE KINETICS) THERMAL WIRE STRIPPER w/ STAND
A17.	DRK35-18 (DANIELS) INSTALLING TOOL
A18.	DRK35-18 (DANIELS) REMOVAL TOOL
A19.	DRK35-20 (DANIELS) INSTALLING TOOL
A20.	DRK35-20 (DANIELS) REMOVAL TOOL
A21.	DRK35-188 (DANIELS) INSTALLING TOOL
A22.	DRK35-188 (DANIELS) REMOVAL TOOL
A23.	DRK145 (DANIELS) REMOVAL TOOL
A24.	DAK208 (DANIELS) INSTALLING TOOL
A25.	DAK188 (DANIELS) INSTALLING TOOL
A26.	DAK128 (DANIELS) INSTALLING TOOL
A27.	45-182 (DEAL) COAXIAL CABLE STRIPPER
A28.	45-183 (DEAL) COAXIAL CABLE STRIPPER
A29.	45-185 (DEAL) COAXIAL CABLE STRIPPER
A30.	45-184 (DEAL) COAXIAL CABLE STRIPPER
A31.	45-125 (DEAL) WIRE CUTTER

Contents Charts

M22520/1-01 CRIMP TOOL (DANIELS AF8)

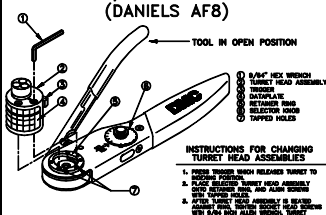

INSTRUCTIONS FOR CHANGING TURRET HEAD ASSEMBLIES

1. PUSH BUSH WHICH RELEASES TURRET TO INDEX POSITION.
2. PLACE SELECTED TURRET HEAD ASSEMBLY OVER CONTACTS AND ALIGN SPRING WITH CONTACTS.
3. AFTER TURRET HEAD ASSEMBLY IS SEATED, PUSH BUSH WHICH RELEASES TURRET TO INDEX POSITION. TURRET HEAD ASSEMBLY WILL BE LOCKED INTO POSITION.
4. TO REMOVE TURRET HEAD ASSEMBLY, PUSH BUSH WHICH RELEASES TURRET TO INDEX POSITION.

INSTRUCTIONS FOR INDEXING TURRET HEAD ASSEMBLIES

1. PUSH BUSH WHICH RELEASES TURRET TO INDEX POSITION.
2. SELECT POSITIONER TO BE USED BY INDEXING TO THE SOCKET AND INDEXING TO THE POSITIONER.
3. TURN POSITIONER UNTIL IT SHOWS INTO LOCKED POSITION.

INSTRUCTIONS FOR USING INDEXER CLOSURE SELECTOR

1. REFER TO PARTS OF TURRET HEAD ASSEMBLY TO IDENTIFY POSITIONER TO BE USED.
2. TURN POSITIONER TO INDEX POSITION.
3. PUSH POSITIONER TO INDEX POSITION.
4. PUSH POSITIONER TO INDEX POSITION.
5. PUSH POSITIONER THROUGH BUSH WHICH RELEASES TURRET TO INDEX POSITION.

M22520/2-01 CRIMP TOOL (DANIELS AFM8)

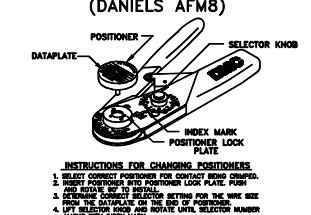

INSTRUCTIONS FOR CHANGING POSITIONERS

1. SELECT CORRECT POSITIONER FOR CONTACT HEAD CRIMPING.
2. INSERT POSITIONER INTO POSITIONER LOCK PLATE. PUSH AND ROTATE TO 75 DEGREE.
3. DETERMINE CONTACT SELECTOR SETTING FOR THE WIRE SIZE.
4. TURN CONTACT SELECTOR UNTIL POSITIONER IS SEATED.
5. TURN CONTACT SELECTOR UNTIL POSITIONER IS SEATED WITH INDEX MARK.
6. TOOL IS NOW READY FOR USE.

CRIMPING INSTRUCTIONS

1. INSERT CONTACT THROUGH INDEXER OPENING AND INTO POSITIONER.
2. INSERT WIRE INTO CONTACT AND HOLD SECURELY TO INSURE THAT IT ROTATES IN CONTACT. CLOSE HANDLE UNTIL TOOL BOTTOMS AND WATCH CONTACT HEAD. RELEASE HANDLES AND RELEASE CRIMPED CONTACT.

NOTE: AFTER CRIMPING CYCLE IS COMPLETED, INSPECT CONTACT. MAKE SURE THE WIRE IS VISIBLE THROUGH THE INSPECTION HOLE OF THE CONTACT AND THERE ARE NO FRAYURES IN THE CONTACT.

Instruction Sheets

TECHNICAL DATA PACKAGE

The technical data package is affixed to the Kit and protected by transparent, plastic lamination to prevent environmental damage. DMC has years of experience in supporting the connector industry. This experience has enabled DMC to develop a wealth of information which can be easily accessed in the technical data package in your Kit. The technical data package typically consists of three sets of data: Contents Charts, Tool Instruction Sheets, and Tool Selection charts.

CONTENTS CHARTS

Increase Efficiency/Reduce FOD. These charts offer a visual representation of the storage compartments for all tools in the kit. These charts enable the technician to quickly scan the kit to be assured that no tools are missing prior to making a repair. While this obviously allows the user to easily locate the required tools, it also decreases the likelihood that important components will become lost or left behind in areas where they may later cause damage to electrical circuitry, or system failure (Foreign Object Debris-F.O.D.). The contents charts also list all the tools by part number, so re-ordering information is immediately available should a component require replacement. All tools are identified by common industry part numbers, and available from the normal supply chain.

INSTRUCTION SHEETS

DMC provides detailed step-by-step directions on how to prepare each tool for use. Instruction sheets are also available to meet foreign language or unique special purpose tool requirements for wire prep, termination, and assembly.

Tool Selection Charts

TOOL SELECTION CHARTS

Eliminate Trial And Error Tool Selection. These detailed charts are developed from the actual connector lists of the system being supported, and are designed to direct the technician in the selection of the proper tools and accessories. DMC does all the research to cross reference the appropriate tooling for proper assembly, repair, and disassembly of the power, RF, and other wire terminations in the system.

The tool selection charts identify the connectors in alpha/numeric order by their military and/or commercial designations; identify the contacts by part number and color code where applicable; list applicable wire sizes; and identify the appropriate crimp tool and associated turret head/positioner/die, installing tool and removal tool for wired and unwired contacts where applicable. The Tool Selection Charts include information on the replacement parts for the connectors & wiring devices.

DMC1264 TOOL SELECTION CHART														
WIRE SIZE	CONNECTOR	CONTACT	COLOR	WIRE GAUGE	WIRE TYPE	CRIMP TOOL	TURRET HEAD POSITIONER OR DIE SET	INSTALLING TOOL	REMOVAL TOOL	REMOVAL TOOL FOR UNWIRED CONTACTS				
										PART NUMBER	PART NUMBER	PART NUMBER	PART NUMBER	PART NUMBER
MIL-DTL-38999	CIRCULAR FRONT RELEASE CONTACTS	M39029-240	P RED	20-24	CG22	AFMB (M22520/2-01)	M81969/14-01 (GREEN END)	M81969/14-01 (GREEN END)	M81969/14-01 (GREEN END)	M81969/14-01 (GREEN END)	M81969/14-01 (GREEN END)	M81969/14-01 (GREEN END)	M81969/14-01 (GREEN END)	M81969/14-01 (GREEN END)
M39029-238		P RED	18-20	CG16	AFMB (M22520/2-01)	M81969/14-01 (GREEN END)	M81969/14-01 (GREEN END)	M81969/14-01 (GREEN END)	M81969/14-01 (GREEN END)	M81969/14-01 (GREEN END)	M81969/14-01 (GREEN END)	M81969/14-01 (GREEN END)	M81969/14-01 (GREEN END)	
M39029-247		P RED	12-14	CG12	AFMB (M22520/2-01)	M81969/14-01 (GREEN END)	M81969/14-01 (GREEN END)	M81969/14-01 (GREEN END)	M81969/14-01 (GREEN END)	M81969/14-01 (GREEN END)	M81969/14-01 (GREEN END)	M81969/14-01 (GREEN END)	M81969/14-01 (GREEN END)	

WORLDWIDE SUPPORT

DMC has developed a worldwide network of professionals to aid you in answering technical questions, designing new service kits, modifying existing kits, and processing orders for kits and individual components. DMC is continually working with the government and major manufacturers towards the development of support materials to keep pace with the most recent developments in technology. DMC's full service facility in Orlando, Florida, has a qualified staff to recalibrate tools to meet FAA requirements and to refurbish kits. As you continually review changes in your interconnect systems and forward this information to DMC, we will update your Tool Kit to support any new configurations. DMC will remain your partner long after you receive your initial Wiring System Service Kit, so you will keep current with all the advances made by the connector industry.

Tool Selection Charts

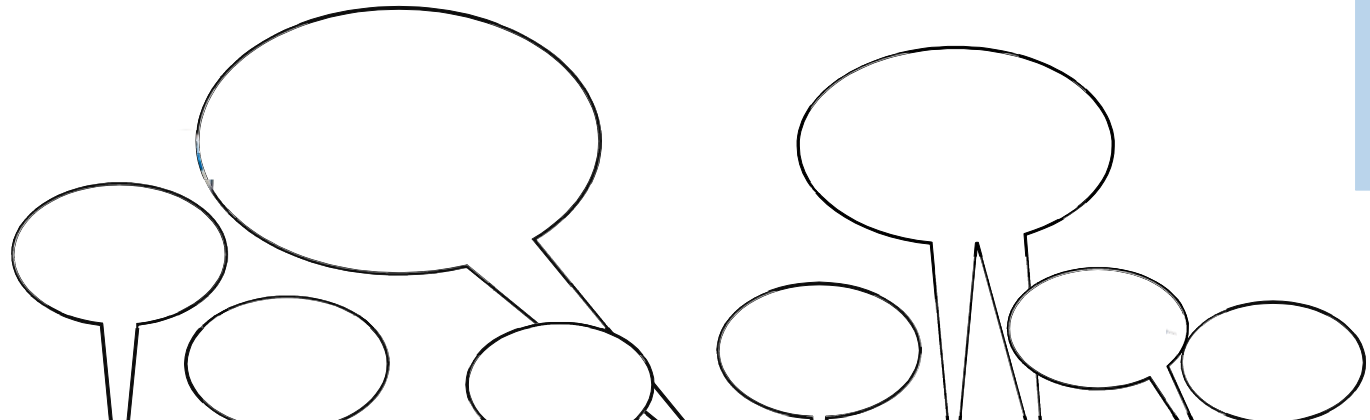

DMC1264 TOOL SELECTION CHART														
WIRE SIZE	CONNECTOR	CONTACT	COLOR	WIRE GAUGE	WIRE TYPE	CRIMP TOOL	TURRET HEAD POSITIONER OR DIE SET	INSTALLING TOOL	REMOVAL TOOL	REMOVAL TOOL FOR UNWIRED CONTACTS				
										PART NUMBER	PART NUMBER	PART NUMBER	PART NUMBER	PART NUMBER
MIL-DTL-38999	CIRCULAR REAR RELEASE CONTACTS	M527508E1853S	S ORN	22	CG22	AFMB (M22520/2-01)	M81969/14-01 (GREEN END)	M81969/14-01 (GREEN END)	M81969/14-01 (GREEN END)	M81969/14-01 (GREEN END)	M81969/14-01 (GREEN END)	M81969/14-01 (GREEN END)	M81969/14-01 (GREEN END)	M81969/14-01 (GREEN END)
M39029/57-356		S GRN	22	CG22	AFMB (M22520/2-01)	M81969/14-01 (GREEN END)	M81969/14-01 (GREEN END)	M81969/14-01 (GREEN END)	M81969/14-01 (GREEN END)	M81969/14-01 (GREEN END)	M81969/14-01 (GREEN END)	M81969/14-01 (GREEN END)	M81969/14-01 (GREEN END)	

Refurbishment & Repair of DMC Maintenance Kits

DMC offers comprehensive refurbishment and repair of all of our Maintenance Kits. Our trained personnel are available with the information and tools you need to keep your kit up-to-date and in production. Each tool in your kit will be inspected and calibrated, and if necessary, repaired or replaced. In addition, the kit will be evaluated to ensure it is up-to-date and can support the latest version of your aircraft. Finally, an optional certificate of calibration can be created that covers every tool within the kit. See page 180 for more info.

Repair and Calibration

DMC Offers Repair & Calibration for All DMC Tools

DMC has earned a reputation for High Quality and Reliable Tooling throughout the world. Our tools and related products have been used to manufacture and support some of the most complex and sophisticated systems in the Aerospace Industry, and we are proud to support what we sell with factory repair and calibration services.

When you send your tool(s) to the DMC Factory in Orlando, FL USA, or an authorized DMC Repair/Calibration Center, our experienced factory trained technicians will evaluate your tool, and when repairs are justified, original DMC Factory Parts and Equipment will be used to restore the tool to the required level of performance to which it was designed.

We strongly recommend periodic Go-No/Go Gage Inspection of all Crimp Tools and Dies used in wiring production, and when the Gage Inspection indicates a tool has experienced wear or abuse, it is time for DMC Factory Repair. **Certificates available upon request.**

Repair & Calibration of Alpatron® Tensile Testers

DMC offers complete repair and calibration services for our entire line of Alpatron® Tensile Testers. Our skilled technicians will inspect the hardware and software of your Alpatron® Tensile Tester. The unit will be calibrated and updated with the latest software. An optional certificate of calibration with before and after readings is available.

Refurbishment & Repair of DMC Maintenance Kits

DMC offers comprehensive refurbishment and repair of all of our Maintenance Kits. Our trained personnel are available with the information and tools you need to keep your kit up-to-date and in production. Each tool in your kit will be inspected and calibrated, and if necessary, repaired or replaced. In addition, the kit will be evaluated to ensure it is up-to-date and can support the latest version of your aircraft. Finally, an optional certificate of calibration can be created that covers every tool within the kit.

Contact DMC to Learn More

Our Customer Service team is available to assist in coordinating the repair and calibration of your tooling. Please contact us at: (407) 855-6161 or dmc@dmctools.com.

World-Wide Support

Outside of the United States, we have Authorized DMC Repair Facilities globally to assist you in getting your tooling repaired and back into production. Please visit: <http://www.dmctools.com/Support/support.html>

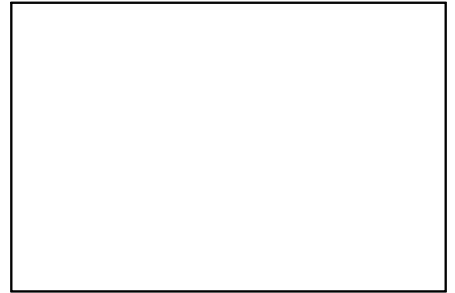

Repair and Calibration

DMC Repairs and Calibrates
Hand Crimp Tool, 4 Indent (AF, AFM, MH, M, GS)
Pneumatic 4-Indent Crimp Tools (WA22, WA27)
WA23 Pneumatic Crimp Tool (Large AWG)
Open Frame (HX3, HX4, UDT3, UDT4)
Open Frame Pneumatic Crimp Tools (HX23, PHX3, HX33)
GMT Style Crimp Tools
DBS Style Banding Tools
Pneumatic Banding Tools (PBT, PMBT)
Hydraulic Crimp Tools (HD36, HD51, HD120)
Hydraulic Safe-T-Cable with Nose Replacement
Hydraulic Safe-T-Cable without Nose Replacement
Battery Operated Crimp Tools (AFE8B, HXE4B, HDE36B, HDE51B, HDE120, EMC3300)
Alphatron Tensile Tester (PT, HPT, MPT, RTCG, DBS-CG4D) (Calibration Only, Repair Quoted Separate)
Safe-T-Cable Tools without Nose Replacement (SCT/SCTR)
Pneumatic Safe-T-Cable Tools without Nose Replacement (SCTP/SCTPR)
Safe-T-Cable Tools with Nose Replacement (SCT/SCTR)
Battery Operated Safe-T-Cable with Nose Replacement (SCTE)
Battery Operated Safe-T-Cable without Nose Replacement (SCTE)
Pneumatic Safe-T-Cable Tools with Nose Replacement (SCTP/SCTPR)
Twist Strip Tool
Signed Certificate of Calibration without Readings with Qualifying Repair listed above
DBS Calibration Fixture (DBS-CG1)
DBS Calibration Fixture (DBS-CG2, -CG3, -CG7, -CG8)
Signed Certificate of Calibration with Readings with Qualifying Repair listed above
Calibration Only with Signed Certificate of Calibration without Readings
Calibration Only with Signed Certificate of Calibration with Readings

Contact DMC for pricing

Limited Warranty

LIMITED WARRANTY

LIMITED WARRANTY: DMC warrants each new product sold by it to be free from defects in material and workmanship under normal use and service. DMC's obligation under this warranty is limited to the free correction or, at DMC's option, the refund of the purchase price of any such product which proves defective in normal service within ninety (90) days after delivery to the first user, provided that the product is returned to DMC with all transportation charges prepaid and which shall appear to DMC's satisfaction, after DMC's inspection, to have been

defective in material or workmanship, it being understood that DMC products are not consumer products. This warranty shall not cover any damage to any product which, in the opinion of DMC, was caused by normal wear, misuse, improper operation, tampering, neglect, or accident.

This warranty is in lieu of all other warranties express or implied. No warranty, express or implied, is made or authorized to be made or assumed with respect to products of Daniels Manufacturing Corporation other than those herein set forth.

Contact DMC for pricing

ERGONOMICS CHALLENGE

Ergonomic guidelines set for less demanding and mechanically complicated hand tools (such as hammers, wrenches, wire cutters and pliers) cannot be applied to crimping tools which require thousands of pounds of force.

DMC's years of experience as a leader in the crimp tool industry have confirmed that the most effective ergonomic improvements for workers can be achieved by substituting power assisted crimp tools for existing hand crimp tools wherever feasible. DMC's pneumatic, hydraulic, and battery operated power assisted crimp tools are already supporting OEM Production Line Operations where crimping is being done 24/7.

For hand crimp tools, DMC's ergonomic philosophy is to design the most mechanically efficient hand crimp tool linkage possible and to fit the hand crimp tools with comfortable grips and handle shapes, thereby producing ergonomic hand crimp tools with the same quality, precision, and repeatability that have become synonymous with the DMC name.

The solution to the Ergonomics Challenge is to provide power assisted crimp tools for all crimping operations of sufficient volume where the user will see the value of ergonomic benefits.

